



**Economic and Social  
Council**

Distr.  
GENERAL

ECE/TRANS/WP.29/GRE/2009/15  
16 January 2009

Original: ENGLISH  
ENGLISH AND FRENCH ONLY

---

**ECONOMIC COMMISSION FOR EUROPE**

**INLAND TRANSPORT COMMITTEE**

World Forum for Harmonization of Vehicle Regulations

Working Party on Lighting and Light-Signalling

Sixty-first session

Geneva, 30 March - 3 April 2009

Item 3(a) of the provisional agenda

**REGULATION No. 37**  
**(Filament lamps)**

**Proposal for Supplement 34 to the 03 series of amendments**

**Submitted by the expert from the Working Party "Brussels 1952" \*/**

The text reproduced below was prepared by the expert from the Working Party "Brussels 1952" (GTB) in order to introduce into Regulation No. 37 the provisions for a new category of filament light source H16. The proposal is based on the current text of the Regulation including draft Supplement 33 to the 03 series of amendments. The modifications to the existing text of the Regulation are marked in bold characters.

---

\*/ In accordance with the programme of work of the Inland Transport Committee for 2006-2010 (ECE/TRANS/166/Add.1, programme activity 02.4), the World Forum will develop, harmonize and update Regulations in order to enhance performance of vehicles. The present document is submitted in conformity with that mandate.

A. PROPOSAL

Annex 1,

The list of categories of filament lamps, grouped, and their sheets, amend to read:

"

Group 1

Without general restrictions:

<u>Category</u>	<u>Sheet number(s)</u>
H1	H1/1 to 3
...	
H15	H15/1 to 5
<b>H16</b>	<b>H16/1 to 4</b>
H21W <u>**/</u>	H21W/1 to 2
...	

"

The list of sheets for filament lamps and their sequence, amend to read:

"

Sheet number(s)

...  
H15/1 to 5  
**H16/1 to 4**  
H6W/1

"

Insert new sheets H16/1 to 4, between sheet H15/5 and H6W/1, to read (see next pages):

"

CATEGORY H16

Sheet H16/1

The drawings are intended only to illustrate the essential dimensions (in mm) of the filament lamp

Category H16

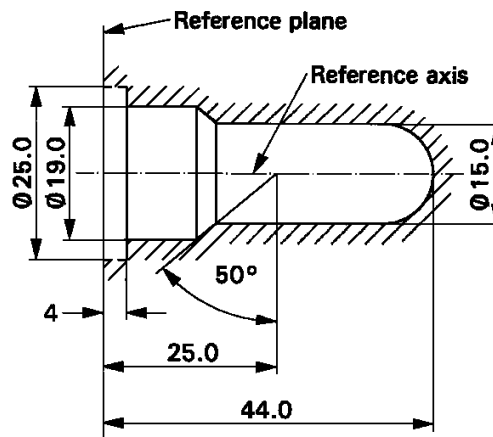
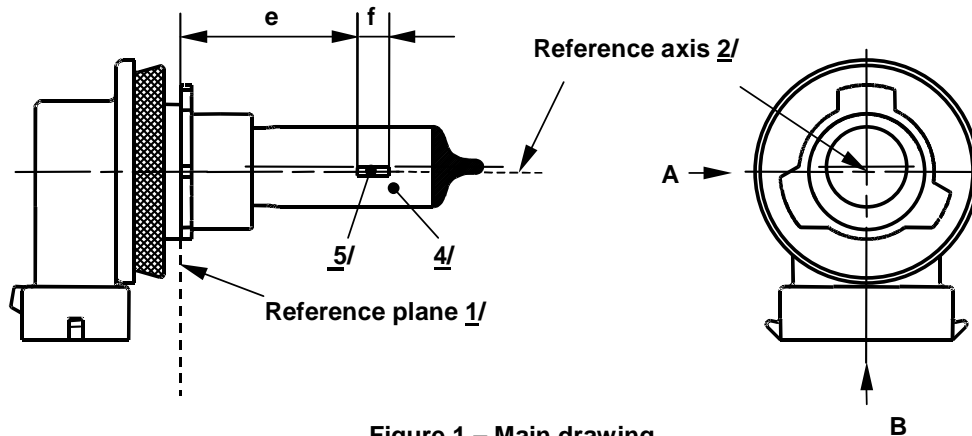

- 1/ The reference plane is the plane formed by the underside of the bevelled lead-in flange of the cap.
- 2/ The reference axis is perpendicular to the reference plane and passing through the centre of the 19 mm cap diameter.
- 3/ Glass bulb and supports shall not exceed the envelope as indicated in Figure 2. The envelope is concentric to the reference axis.
- 4/ The light emitted shall be white or selective yellow.
- 5/ Notes concerning the filament diameter.
  - No actual diameter restrictions apply but the objective for future developments is to have  $d_{max.} = 0.9$  mm.
  - For the same manufacturer, the design diameter of standard (étalon) filament lamp and filament lamp of normal production shall be the same.

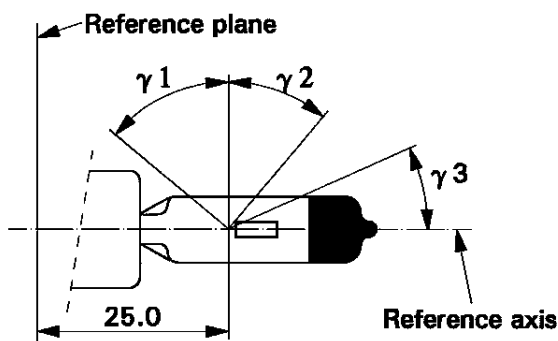

View B

Figure 3  
Distortion free area 6/ and black top 7/

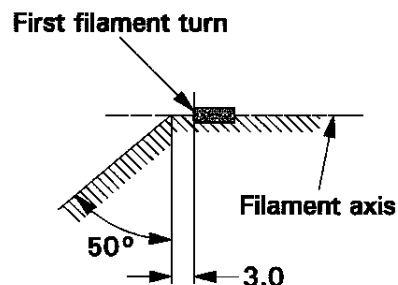

View A

Figure 4  
Metal free zone 8/

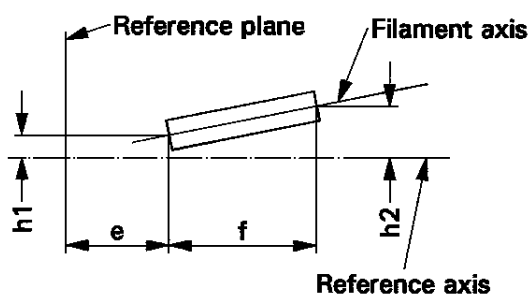

Figure 5

Permissible offset of filament axis 9/  
(for standard filament lamps only)

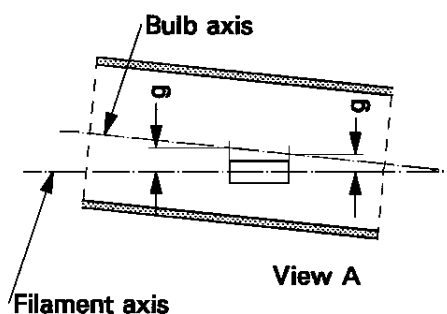

Figure 6

Bulb eccentricity 10/

- 6/ Glass bulb shall be optically distortion free within the angles  $\gamma_1$  and  $\gamma_2$ . This requirement applies to the whole bulb circumference within the angles  $\gamma_1$  and  $\gamma_2$ .
- 7/ The obscuration shall extend at least to angle  $\gamma_3$  and shall extend at least to the cylindrical part of the bulb on the whole bulb top circumference.
- 8/ The internal design of the lamp shall be such that stray light images and reflections are only located above the filament itself seen from the horizontal direction. (View A as indicated in Figure 1 on sheet H16/1). No metal parts other than filament turns shall be located in the shaded area as seen in Figure 4.
- 9/ The offset of the filament with respect to the reference axis is measured only in viewing directions A and B as shown in Figure 1 in sheet H16/1. The points to be measured are those where the projection of the outside of the end turns nearest to or furthest from the reference plane crosses the filament axis.
- 10/ Offset of filament in relation to bulb axis measured in two planes parallel to the reference plane where the projection of the outside of the end turns nearest to or furthest from the reference plane crosses the filament axis.

**CATEGORY H16**

**Sheet H16/3**

Dimensions in mm		Filaments lamps of normal production		Standard filament lamp
		12 V		12 V
e	11/	25.0	12/	25.0 ± 0.1
f	11/	3.2	12/	3.2 ± 0.1
g		0.5 min.		u.c.
h1		0	12/	0 ± 0.1
h2		0	12/	0 ± 0.15
γ1		50° min.		50° min.
γ2		40° min.		40° min.
γ3		30° min.		30° min.
Cap: H16: PGJ19-3 in accordance with IEC Publication 60061 (sheet 7004-110-2)				
<b>ELECTRICAL AND PHOTOMETRIC CHARACTERISTICS</b>				
Rated values	Volts	12		12
	Watts	19		19
Test voltage	Volts	13.2		13.2
Objective values	Watts	22 max.		22 max.
	Luminous flux	500 +10% / -15 %		
Reference luminous flux: 500 lm at approximately 13.2 V				
Reference luminous flux: 550 lm at approximately 13.5 V				

11/ The ends of the filament are defined as the points where, when the viewing direction is direction A as shown in Figure 1 on sheet H16/1, the projection of the outside of the end turns crosses the filament axis.

12/ To be checked by means of a "Box System"; sheet H16/4.

Screen projection requirements

This test is used to determine, by checking whether the filament is correctly positioned relative to the reference axis and reference plane, whether a filament complies with the requirements.

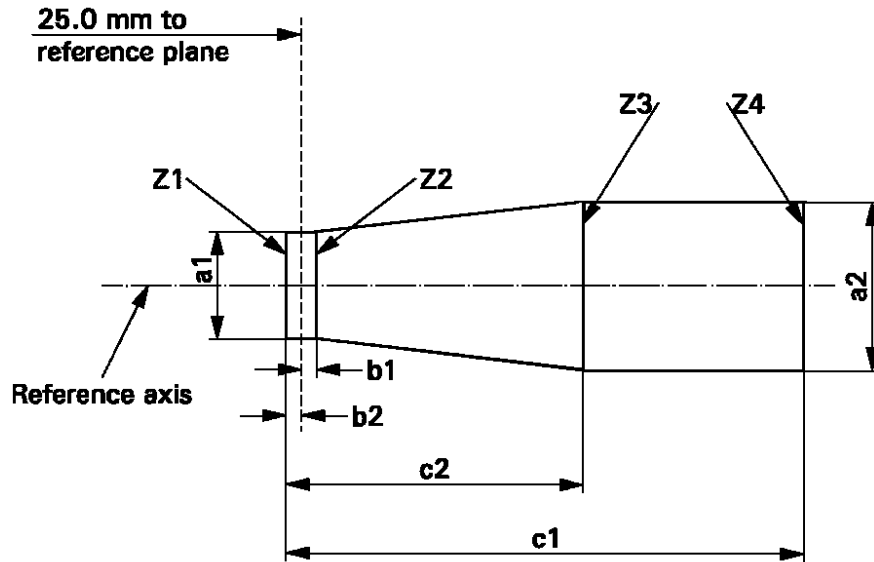

a1	a2	b1	b2	c1	c2
d + 0.50	d + 0.70	0.25		3.6	2.6

d = diameter of filament

The filament position is checked solely in directions A and B as shown on sheet H16/1, Figure 1.

The filament shall lie entirely within the limits shown.

The ends of the filament as defined on sheet H16/3, note 11/, shall lie between lines Z1 and Z2 and between Z3 and Z4."

B. JUSTIFICATION

The new category H16 is intended for Regulation No. 37 without usage restrictions, to be used for front lighting and signalling applications e.g. for beam contributors in adaptive front-lighting systems (AFS), cornering lamps, bend lighting, front fog lamps and / or for daytime running lamps (DRL).

-----