



**Economic and Social  
Council**

Distr.  
GENERAL

ECE/TRANS/WP.29/2009/22  
17 December 2008

Original: ENGLISH

---

**ECONOMIC COMMISSION FOR EUROPE**

**INLAND TRANSPORT COMMITTEE**

**World Forum for Harmonization of Vehicle Regulations**

One-hundred-and-forty-seventh session  
Geneva, 10 - 13 March 2009  
Item 4.2.18 of the provisional agenda

**1958 AGREEMENT**

Consideration of draft amendments to existing Regulations

Proposal for Supplement 3 to the 04 series of amendments to Regulation No. 48  
(Installation of lighting and light-signalling devices)

Submitted by the Working Party on Lighting and Light-Signalling (GRE) \*/

The text reproduced below was adopted by GRE at its sixtieth session. It is based on GRE-60-04, GRE-60-07, and GRE-60-11, as reproduced in Annex II to the report, on ECE/TRANS/WP.29/GRE/2008/31, as amended by Annex III to the report, on ECE/TRANS/WP.29/GRE/2008/34, not amended, on ECE/TRANS/WP.29/GRE/2008/53, as amended by Annex II to the report and on and ECE/TRANS/WP.29/GRE/2008/57, as amended by para. 10. of the report. It is submitted to WP.29 and AC.1 for consideration (ECE/TRANS/WP.29/GRE/60, paras. 8, 9, 10, 14, 22, 26 and 28).

---

\*/ In accordance with the programme of work of the Inland Transport Committee for 2006-2010 (ECE/TRANS/166/Add.1, programme activity 02.4), the World Forum will develop, harmonize and update Regulations in order to enhance performance of vehicles. The present document is submitted in conformity with that mandate.

Paragraphs 2.7.3. to 2.7.6., amend to read:

- "2.7.3.     "Independent lamps" means devices having separate apparent surfaces in the direction of the reference axis, 2/ separate light sources and separate lamp bodies;
- 2.7.4.     "Grouped lamps" means devices having separate apparent surfaces in the direction of the reference axis 2/ and separate light sources, but a common lamp body;
- 2.7.5.     "Combined lamps" means devices having separate apparent surfaces in the direction of the reference axis, 2/ but a common light source and a common lamp body;
- 2.7.6.     "Reciprocally incorporated lamps" means devices having separate light sources or a single light source operating under different conditions (for example, optical, mechanical, electrical differences), totally or partially common apparent surfaces in the direction of the reference axis 2/ and a common lamp body;"

Footnote 2, amend to read:

---

2/         In the case of lighting devices for the rear registration plate and direction-indicators of categories 5 and 6, the "light-emitting surface" shall be used."

Paragraph 2.8., amend to read:

- "2.8.         "Light emitting surface" of a "lighting device", "light-signalling device" or a retro-reflector means the surface as declared in the request for approval by the manufacturer of the device on the drawing, see Annex 3;

This shall be declared according to one of the following conditions:

- a) in the case where the outer lens is textured, the declared light emitting surface shall be all or part of the exterior surface of the outer lens
- b) in the case where the outer lens is non-textured the outer lens may be disregarded and the light emitting surface shall be as declared on the drawing, see Annex 3."

Insert new paragraphs 2.30. to 2.32.1., to read (insert a reference to footnote 3/ and footnote 3/):

"2.30. Night-time Colour of the light retro-reflected from a device excluding retro-reflective tires according to Regulation No. 88

2.30.1. "White" means the chromaticity coordinates (x,y) 3/ of the light reflected that lie inside the chromaticity areas defined by the boundaries:

W <sub>12</sub>	Blue Boundary:	y=0.843 - 1.182x
W <sub>23</sub>	Violet Boundary:	y=0.489x + 0.146
W <sub>34</sub>	Yellow Boundary:	y=0.968 - 1.010x
W <sub>41</sub>	Green Boundary:	y=1.442x - 0.136

with intersection points:

	x	y
W <sub>1</sub>	0.373	0.402
W <sub>2</sub>	0.417	0.350
W <sub>3</sub>	0.548	0.414
W <sub>4</sub>	0.450	0.513

2.30.2. "Yellow" means the chromaticity coordinates (x,y) 3/ of the light reflected that lie inside the chromaticity areas defined by the boundaries:

Y <sub>12</sub>	Green Boundary:	y=x - 0.040
Y <sub>23</sub>	The Spectral Locus	
Y <sub>34</sub>	Red Boundary:	y=0.200x + 0.268
Y <sub>41</sub>	White Boundary:	y=0.970 - x

with intersection points:

	x	y
Y <sub>1</sub>	0.505	0.465
Y <sub>2</sub>	0.520	0.480
Y <sub>3</sub>	0.610	0.390
Y <sub>4</sub>	0.585	0.385

2.30.3. "Amber" means the chromaticity coordinates (x,y) 3/ of the light reflected that lie inside the chromaticity areas defined by the boundaries:

A <sub>12</sub>	Green Boundary:	y=1.417x - 0.347
A <sub>23</sub>	The Spectral Locus	
A <sub>34</sub>	Red Boundary:	y=0.390
A <sub>41</sub>	White Boundary:	y=0.790 - 0.670x

---

3/ CIE Publication 15.2, 1986, Colorimetry, the CIE 1931 standard colorimetric observer.

with intersection points:

	x	y
A <sub>1</sub>	0.545	0.425
A <sub>2</sub>	0.557	0.442
A <sub>3</sub>	0.609	0.390
A <sub>4</sub>	0.597	0.390

2.30.4. "Red" means the chromaticity coordinates (x,y) 3/ of the light reflected that lie inside the chromaticity areas defined by the boundaries:

R <sub>12</sub>	Yellow Boundary:	y=0.335
R <sub>23</sub>	The Spectral Locus	
R <sub>34</sub>	The Purple Line	
R <sub>41</sub>	Purple Boundary:	y= 0.978 - x

with intersection points:

	x	y
R <sub>1</sub>	0.643	0.335
R <sub>2</sub>	0.665	0.335
R <sub>3</sub>	0.735	0.265
R <sub>4</sub>	0.720	0.258

2.31. Day-time Colour of the light reflected from a device

2.31.1. "White" means the chromaticity coordinates (x,y) 3/ of the light reflected that lie inside the chromaticity areas defined by the boundaries:

W <sub>12</sub>	Violet Boundary	y = x - 0.030
W <sub>23</sub>	Yellow Boundary	y =0.740 - x
W <sub>34</sub>	Green Boundary	y =x + 0,050
W <sub>41</sub>	Blue Boudary	y =0.570 - x

with intersection points:

	x	y
W <sub>1</sub>	0.300	0.270
W <sub>2</sub>	0.385	0.355
W <sub>3</sub>	0.345	0.395
W <sub>4</sub>	0.260	0.310"

2.31.2. "Yellow" means the chromaticity coordinates (x,y)  $\underline{3/}$  of the light reflected that lie inside the chromaticity areas defined by the boundaries:

$Y_{12}$	Red Boundary	$y = 0.534 x + 0.163$
$Y_{23}$	White Boundary	$y = 0.910 - x$
$Y_{34}$	Green Boundary	$y = 1.342 x - 0.090$
$Y_{41}$	The Spectral Locus	

with intersection points:

	x	y
$Y_1$	0.545	0.454
$Y_2$	0.487	0.423
$Y_3$	0.427	0.483
$Y_4$	0.465	0.534

2.31.3. "Red" means the chromaticity coordinates (x,y)  $\underline{3/}$  of the light reflected that lie inside the chromaticity areas defined by the boundaries:

$R_{12}$	Red Boundary	$y = 0.346 - 0.053 x$
$R_{23}$	Purple Boundary	$y = 0.910 - x$
$R_{34}$	Yellow Boundary	$y = 0.350$
$R_{41}$	The Spectral Locus	

with intersection points:

	x	y
$R_1$	0.690	0.310
$R_2$	0.595	0.315
$R_3$	0.560	0.350
$R_4$	0.650	0.350"

2.32. Day-time Colour of the fluorescent a device

2.32.1. "Red" means the chromaticity coordinates (x,y)  $\underline{3/}$  of the light reflected that lie inside the chromaticity areas defined by the boundaries:

$FR_{12}$	Red Boundary	$y = 0.346 - 0.053 x$
$FR_{23}$	Purple Boundary	$y = 0.910 - x$
$FR_{34}$	Yellow Boundary	$y = 0.315 + 0.047 x$
$FR_{41}$	The Spectral Locus	

with intersection points:

	x	y
FR <sub>1</sub>	0,690	0,310
FR <sub>2</sub>	0,595	0,315
FR <sub>3</sub>	0,569	0,341
FR <sub>4</sub>	0,655	0,345

"

Insert a new paragraph 3.2.7., to read:

"3.2.7. a description of the electric power supply conditions for the devices indicated in paragraphs 2.7.9, 2.7.10, 2.7.12, 2.7.14 and 2.7.15 above, including, if applicable, information on a special power supply/electronic light source control gear, or variable intensity control."

Insert a new paragraph 5.7.1.1., to read:

"5.7.1.1. The photometric and ...switched OFF.

However, when a front or rear position lamp is reciprocally incorporated with one or more other function(s) which can be activated together with them, the requirements ..."

Paragraphs 5.7.1.2. to 5.7.2.1., amend to read:

"5.7.1.2. Stop lamps and direction indicator lamps are not permitted to be reciprocally incorporated.

5.7.1.3. Where stop lamps and direction indicator lamps are grouped, the following conditions shall be met:

5.7.1.3.1. any horizontal or vertical straight line passing through the projections of the apparent surfaces of these functions on a plane perpendicular to the reference axis, shall not intersect more than two borderlines separating adjacent areas of different colour;

5.7.1.3.2. their apparent surfaces in the direction of the reference axis, based upon the areas bounded by the outline of their light emitting surfaces, do not overlap.

5.7.2. Where the apparent surface of a single lamp is composed of two or more distinct parts, it shall satisfy the following requirements:

5.7.2.1. Either the total area of the projection of the distinct parts on a plane tangent to the exterior surface of the outer lens and perpendicular to the reference axis shall occupy not less than 60 per cent of the smallest quadrilateral circumscribing the said projection, or the distance between two adjacent/tangential distinct parts shall not exceed 15 mm when measured perpendicularly to the reference axis."

Paragraph 5.11., amend to read:

- "5.11. The electrical connections shall be such that the front and rear position lamps, the end-outline marker lamps, if they exist, the side-marker lamps, if they exist, and the rear registration plate lamp can only be switched ON and OFF simultaneously.  
This condition does not apply:
- 5.11.1. when front and rear position lamps are switched ON, as well as side-marker lamps when combined or reciprocally incorporated with said lamps, as parking lamps;
- 5.11.2. when side-marker lamps are permitted to flash."

Insert new paragraphs 5.11.3., to read:

- "5.11.3. to front position lamps when their function is substituted under the provisions of paragraph 5.12.1. below."

Paragraph 5.12., amend to read:

- "5.12. The electrical connections shall be such that .... and dipped-beam headlamps;"

Insert new paragraphs 5.12.1.to 5.12.1.3., to read:

- "5.12.1. The dipped-beam headlamps and/or the main-beam headlamps and/or the front fog lamps may substitute the function of the front position lamps, provided that:
- 5.12.1.1. their electrical connections are such that in case of failure of any of these lighting devices the front position lamps are automatically re-activated,  
and
- 5.12.1.2. the substituting lamp/function meets, for the respective position lamp, the requirements concerning:  
(a) the geometric visibility prescribed for the front position lamps in paragraph 6.9.5; and  
(b) the minimum photometric values according to the angles of light distribution.  
and
- 5.12.1.3. appropriate evidence demonstrating compliance with the requirements indicated in paragraph 5.12.1.2. above is provided in the test reports of the substituting lamp."

Insert new paragraph 5.27., to read:

- "5.27. The applicant shall demonstrate to the Technical Service responsible for type approval testing that the electric power supply conditions for the devices indicated

in 2.7.9, 2.7.10, 2.7.12, 2.7.14 and 2.7.15 above comply, when the electrical system of the vehicle is in a constant voltage operating condition, representative for the relevant category of powered vehicle as specified by the applicant, with the following provisions:

- 5.27.1. The voltage supplied at the terminals of devices which, according to their type approval documentation, have been tested by the application of a special power supply/electronic light source control gear, or in a secondary operating mode or at a voltage requested by the applicant, shall not exceed the voltage specified for the relevant devices or functions as they have been approved.
- 5.27.2. In all cases of electric power supply conditions not covered by paragraph 5.27.1, the voltage at the terminals of the device(s) or function(s) shall not exceed 6.75V (6 Volt-Systems), 13.5V (12 Volt-Systems) or 28.V (24 Volt-Systems) by more than 3 percent."
- 5.27.3. The provisions of paragraphs 5.27.1. and 5.27.2. shall not apply to devices which include an electronic light source control gear or a variable intensity control being part of the device.
- 5.27.4. A report shall be attached to the approval documentation describing the methods used to demonstrate compliance and the results obtained."

Paragraph 6.1.9.1., amend to read:

- "6.1.9.1. The aggregate maximum intensity of the main-beam headlamps which can be switched on simultaneously shall not exceed 300,000 cd, which corresponds to a reference value of 100."



Paragraph 6.5.5.1., amend to read:

"6.5.5.1. Horizontal angles, (see figure below)

Vertical angles: 15° above and below the horizontal for direction-indicator lamps of categories 1, 1a, 1b, 2a, 2b and 5. The vertical angle below the horizontal may be reduced to 5° if the lamps are less than 750 mm above the ground; 30° above and 5° below the horizontal for direction-indicator lamps of category 6. The vertical angle above the horizontal may be reduced to 5° if the optional lamps are not less than 2,100 mm above the ground.

FIGURE (see paragraph 6. 5.)

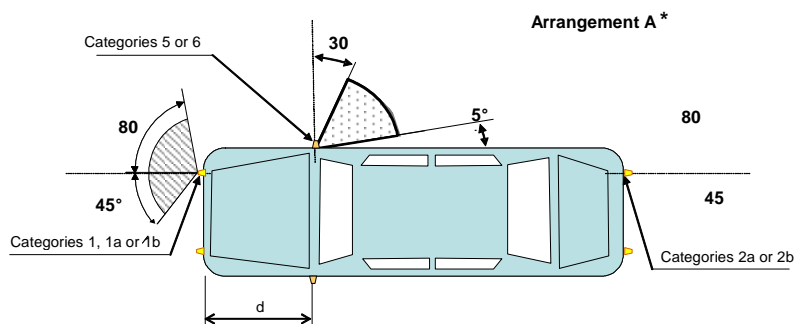

For M1 and N1 category vehicles, the value of 45° inward for the direction indicator lamps of categories 1, 1a or 1b, whose lower edge of the apparent surface is less than 750 mm above the ground, may be reduced to 20° under the horizontal plane containing the reference axis of this lamp.

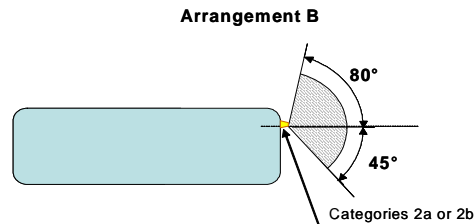

(\*) The value of 5° given for dead angle of visibility to the rear of the side-direction indicator is an upper limit.  $d \leq 1.80$  m( for M<sub>1</sub> and N<sub>1</sub> category vehicles  $d \leq 2.50$  m)."

Paragraph 6.5.5.2., amend to read:

"6.5.5.2. or, at the discretion of the manufacturer, for M<sub>1</sub> and N<sub>1</sub> category vehicles (\*\*):

Front and rear direction-indicator lamps, as well as side-marker lamps

Horizontal angles see figure below:

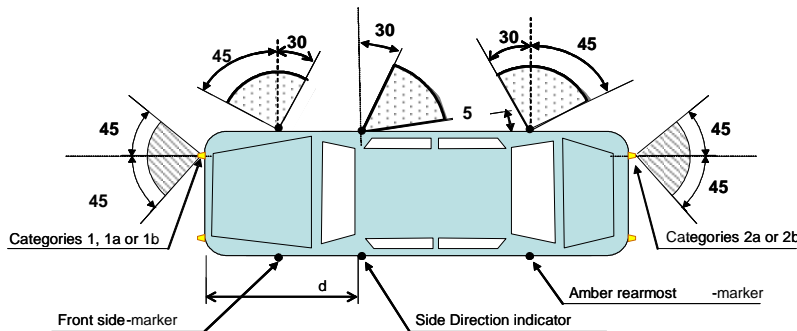

The value of 45° inward for the direction indicator lamps of categories 1, 1a or 1b, whose lower edge of the apparent surface is less than 750 mm above the ground, may be reduced to 20° under the horizontal plane containing the reference axis of this lamp.

Vertical angles: 15°.....

(\*\*) The value of 5° given for dead angle of visibility to the rear of the side-direction indicator is an upper limit.  $d \leq 2.50$  m."

Paragraphs 6.9.5. to 6.9.5.2., amend to read:

"6.9.5. Geometric visibility

6.9.5.1. Horizontal angle for the two position lamps:

45 ° inwards and 80 ° outwards.

For M<sub>1</sub> and N<sub>1</sub> category vehicles where the lower edge of the apparent surface of the lamps is less than 750 mm above the ground, the value of 45° inward may be reduced to 20° under the horizontal plane containing the reference axis of this lamp.

In the case of trailers, ...

6.9.5.2. For M<sub>1</sub> and N<sub>1</sub> category vehicles, as an alternative to paragraph 6.9.5.1., at the discretion of the manufacturer or his duly accredited representative, and only if a front side-marker lamp is installed on the vehicle.

Horizontal angle: 45° outwards to 45° inwards.

Where the lower edge of the apparent surface of the lamps is less than 750 mm above the ground, the value of 45° inward may be reduced to 20° under the horizontal plane containing the reference axis of this lamp.

Vertical angle: 15°..."

Paragraph 6.9.7., amend to read:

"6.9.7. Electrical connections

In accordance with paragraph 5.11.

However, if a front position lamp is reciprocally incorporated with a direction indicator the electrical connection of the front position lamp on the relevant side of the vehicle or the reciprocally incorporated part of it may be such that it is switched off during the entire period (both ON and OFF cycle) of activation of the direction indicator lamp."

Paragraph 6.10.7., amend to read:

"6.10.7. Electrical connections

In accordance with paragraph 5.11.

However, if a rear position lamp is reciprocally incorporated with a direction indicator, the electrical connection of the rear position lamp on the relevant side of the vehicle or the reciprocally incorporated part of it may be such that it is switched OFF during the entire period (both ON and OFF cycle) of activation of the direction indicator lamp."

Paragraph 6.21.4.1.3., amend to read:

"6.21.4.1.3. ... the cumulative length may be reduced to 60 per cent or, if this is not possible in case of especially difficult vehicle designs or applications, to at least 40 per cent and shall be ...."

Paragraph 6.21.4.2.3., amend to read:

"6.21.4.2.3. ... the cumulative length may be reduced to 60 per cent or, if this is not possible in case of especially difficult vehicle designs or applications, to at least 40 per cent and shall be...."

Insert new paragraphs 12.19. and 12.20. to read:

"12.19. As from 36 months from the entry into force of Supplement 3 to the 04 series of amendments, Contracting Parties applying this Regulation shall grant approvals only if the vehicle type to be approved meets the requirements of this Regulation as amended by Supplement 3 to the 04 series of amendments.

12.20. Contracting Parties applying this Regulation shall not refuse to grant extensions of approvals to all previous versions of this Regulation which remain valid."

Insert new paragraph 10.6. in Annex 1, to read:

"10.6. Comments regarding the electrical supply conditions (according to paragraphs 3.2.7 and 5.27 of the regulations)."

-----