

Transmitted by the expert from Japan

Informal Document No. GRE-60-21
(60th GRE, 1-3 October 2008
agenda item 10(a))

Information for Proposed amendments to Regulation No. 53 for headlamp corresponding to inclination

Notes:

1) *The paragraphs below fit into the R53 version before the addition of the IMMA HID and the forthcoming LED text, so the paragraph numbers need to be checked.*

2) *The modifications to the current text of Regulation No.53 are marked in **bold** characters.*

A. PROPOSAL

Insert new paragraph 2.21., 2.22., 2.23., 2.24. and 2.25. to read:

“2. Definitions

“**2.21** “The horizontal inclination” means the angle created between the beam pattern when the motorcycle is set as specified in paragraph 5.4., and the beam pattern when the motorcycle is banked. (see drawing in annex 6)

2.22. “horizontal inclination adjustment system (HIAS)” means a device that adjusts the horizontal inclination of the headlamp towards zero.

2.23 “the bank angle” means: the angle made with the vertical by the vertical longitudinal median plane of the motorcycle, when the motorcycle is rotated about its longitudinal axis. (see drawing in annex 6)

2.24 “signal” means any HIAS control signal or, any additional control input to the system or, a control output from the system to the motorcycle.

2.25 “signal generator” means a device, reproducing one or more of the signals for system test.

Amend Paragraphs 6.1.5., 6.1.8., 6.1.9., 6.2.5.,6.2.8. and 6.2.9. in line with the texts below.

6.1. Driving Beam Headlamp

“6.1.5. Orientation

- 6.1.5.1. Forwards. The lamp(s) may move with the steering angle.
- 6.1.5.2. **A HIAS may be installed.**
- “6.1.8 Tell-tales**
 - 6.1.8.1. ”Circuit-closed” tell-tale
 - 6.1.8.1.1. Mandatory, non-flashing blue signal lamp.
 - 6.1.8.2. **“HIAS failure” tell-tale**
 - 6.1.8.2.1 **Mandatory, flashing amber signal lamp, which may be combined with the tell-tale referred to in paragraph 6.2.8. It shall be activated whenever a failure is detected with respect to the HIAS control signals. It shall remain activated while the failure is present. It may be cancelled in the event of system reset by the rider.**
 - 6.1.9. Other requirements
 - 6.1.9.1. The aggregate maximum intensity of the driving beam headlamps which can be switched on simultaneously shall not exceed 225,000 cd. (The approval value).
 - 6.1.9.2. **In the event of a failure of the HIAS, it shall be possible to reset the system to its initial position, without the use of any special tools.
The manufacturer shall provide with the detailed description of the procedure for resetting.**
- 6.2. Passing Beam Headlamp
 - “6.2.5. Orientation
 - 6.2.5.5. **A HIAS may be installed. However, the adjustment amount of horizontal inclination shall not exceed the vehicle’s bank angle.**
 - 6.2.5.6. **The requirement in paragraph 6.2.5.5. shall be tested in the following conditions:**
 - In the absence of specific instructions, test vehicle shall be set as specified in paragraph 5.4..**
 - Incline the vehicle with the following conditions and measure the angle δ created by headlamp cut-off line (in case of asymmetrical beam headlamp, it's horizontal part of cut-off is used) and HH line. (see drawing in annex 6)**
 - Handlebar may be fixed being in the position corresponding to the straight**

ahead movement for not to move during the vehicle rotation.

For the purpose of HIAS activation during test, the system shall be tested using the signal generator, if applicable.

- maximum horizontal inclination adjustment angle which specified by the manufacturer (to left and to right)
- half of maximum horizontal inclination adjustment angle which specified by the manufacturer (to left and to right)

The system shall be considered satisfy the requirements of paragraph 6.2.5.5.,if all measured angles δ are not less than zero. This may be demonstrated by the manufacturer by other means accepted by the authority responsible for type approval.

“6.2.8. Telltales

6.2.8.1. “Circuit-closed” tell-tale

6.2.8.1.1 Optional; non-flashing green signal lamp.

6.2.8.2. “HIAS failure” tell-tale

6.2.8.2.1 **Mandatory, flashing amber signal lamp, which may be combined with the tell-tale referred to in paragraph 6.1.8. It shall be activated whenever a failure is detected with respect to the HIAS control signals. It shall remain activated while the failure is present. It may be cancelled in the event of system reset by the rider.**

6.2.9. Other requirements

~~None~~

[When the HIAS of a motorcycle cannot meet the requirements of this regulation in the event of failure of the HIAS, it shall be possible to automatically reset the HIAS for the motorcycle to resume the beam pattern when the motorcycle is set as specified in paragraph 5.4. when the passing beam is on.]

Annex 6

Explanation about “the horizontal inclination”, “the bank angle” and the angle “ δ ”.

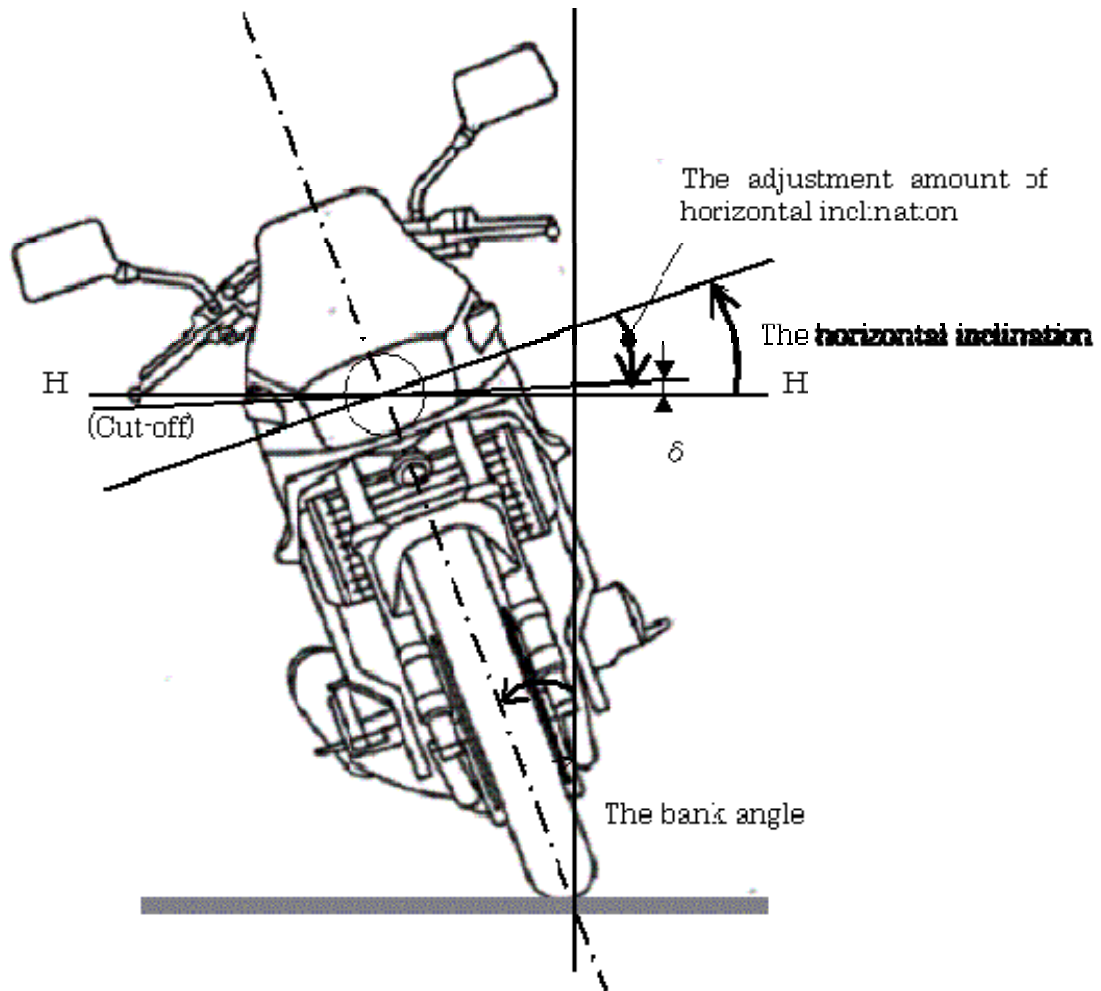

Figure. 3

Note : This figure shows the motorcycle is banked to the right side.

B. JUSTIFICATION

This proposal specifies the requirements concerning the vehicle's horizontal inclination angle adjustment-type headlamps installed on motorcycles.

The Adaptive Front Lighting System (AFS), which improves the visibility by controlling the optical axis with the steering angle and providing additional light sources, has been incorporated into the headlamps for four-wheel vehicles.

In the case of a motorcycle, due to its driving characteristics, the headlamp inclines with the vehicle when the vehicle is running on a curved road, narrowing the illumination area of the headlamp in the traveling direction. Therefore, by adjusting the variation of the headlamp's light distribution from that when the vehicle is upright, *i. e.*, in the standard condition, to keep the illumination area wide enough, the visibility is expected to improve.

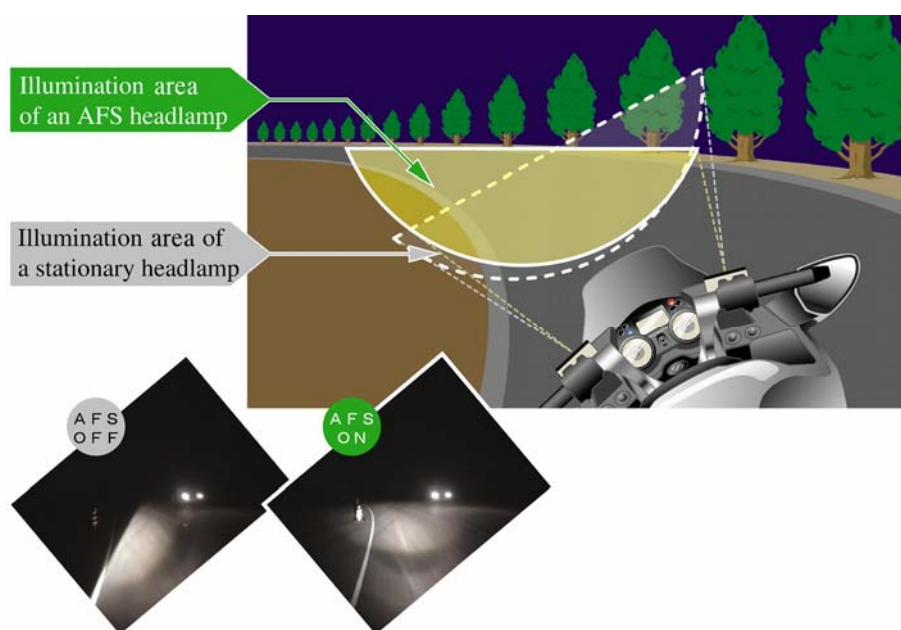

Figure 1. Description of the Function of the Inclination Angle adjustment-Type AFS

To submit this proposal for amendments, we conducted a research on the “vehicle's horizontal inclination angle adjustment-type headlamps for motorcycles” at the Japan Automobile Research Institute (JARI) to confirm the validity by conducting an “evaluation of the visibility” and an “evaluation of the effect on glare”. The result is outlined below.

1. Evaluation of the visibility

It was confirmed that the visibility has improved when the vehicle is running on a curved road and when turning right and left by adjusting the change in the light distribution from when the vehicle is upright.

2. Evaluation of the effect on glare

It was found that generation of glare against oncoming vehicle, which may be caused by this device, can be avoided by ensuring that the maximum adjustment amount of the light distribution of the headlamp is the variation caused by the vehicle inclination.

As for the details of the research at JARI, see Informal Document GRE-59-17.

The following describes the background to each amendment proposed herein:

2. Definitions

- The “horizontal inclination” does not mean an inclination angle of the vehicle. It means the angle created by a change in the beam pattern between when the vehicle is in the upright position and when it is inclined. The HIAS is a device that adjusts this angle.
- Paragraphs 2.24. and 2.25., which have been added, were developed based on Paragraphs 1.10. and 1.11. of ECE R No. 123.

6.1. Driving Beam Headlamp

- Since there is no glare issue for the driving beam headlamp, this paragraph does not contain the requirement “the adjustment amount of horizontal inclination shall not exceed the vehicle’s bank angle,” which is specified for the passing beam headlamp.
- For the “HIAS failure” tell-tale, the indication method and the colour were determined based on Paragraph 6.22.8.2. of ECE R No. 48 and Paragraph 8 of Annex 4 to ECE R No. 60, respectively. The tell-tale shall remain activated while the failure is present. However, when the lamp is reset to its initial position for temporary repair work, the function of the lamp will be the same as that of the conventional lamp equipped with no AFS and therefore the tell-tale will be allowed to be deactivated. In addition, the same tell-tale indicator may be used for both driving beam headlamp and passing beam headlamp.
- In the event of a failure, it shall be possible for the rider to reset the lamp to its initial position without using any special tools, and the detailed information on the resetting procedures shall be provided by the manufacturer.

6.2. Passing Beam Headlamp

- Test procedures for confirming that the adjustment amount of horizontal inclination will not exceed the vehicle’s bank angle have been specified. δ is the angle created by cut-off line and HH line. When this angle is zero or above, no glare will be given to oncoming vehicles. In addition, the statement to the effect that signals for activating the AFS may be input from the outside during testing if necessary, which was developed based on Paragraph 3.1.1. of Annex 9 to ECE R No. 123, has been added.
- The specifications of “HIAS failure” tell-tale are exactly the same as that for driving beam headlamp, and the same indicator may be used for both headlamps.

6.2.9 Other requirements

- The requirement on automatic resetting of the lamp to its initial position in the event of a failure was developed based on Paragraph of 5.7. of ECE R No. 123 and Paragraph 5.9.2. of ECE R No. 112 to ensure the visibility without giving glare to oncoming vehicles.

In Japan, we are still discussing whether this provision is suitable for motorcycles or not, because it may be expensive to fit devices on motorcycles to meet the requirement for the failed HIAS, especially in case of mechanical failure.

Therefore, we need to consider matters, some of which are shown below, to accept manual reset to prevent the glare from the failed HIAS:

- how much harm the failed HIAS would do,

- whether or not the driver of a motorcycle with a failed HIAS would reset the HIAS immediately after the failure occurred,**
- whether manual reset for the HIAS while driving is possible or not.**

This proposal lays the foundation for the dissemination of vehicle's horizontal inclination angle adjustment-type headlamps that always correct the illumination area to that when the vehicle is upright regardless of the vehicle inclination posture. A widespread use of this device will improve the night-time visibility of motorcycles and contribute to the prevention of traffic accidents.
