



**Economic and Social
Council**

Distr.
GENERAL

ECE/TRANS/WP.29/GRE/2007/56
18 July 2007

Original: ENGLISH
ENGLISH AND FRENCH ONLY

ECONOMIC COMMISSION FOR EUROPE

INLAND TRANSPORT COMMITTEE

World Forum for Harmonization of Vehicle Regulations

Working Party on Lighting and Light-Signalling

Fifty-eighth session

Geneva, 1-5 October 2007

Item 3(a) of the provisional agenda

REGULATION No. 37
(Filament lamps)

Provisions for new filament lamp categories

Proposal for draft Supplement 31 to the 03 series of amendments to regulation no. 37

Submitted by the expert from the Working Party "Brussels 1952" (GTB)

The text reproduced below was prepared by the expert from the Working Party "Brussels 1952" (GTB) in order to insert into the Regulation provisions for a 24V version of the dual filament light source of category H15. The proposal is based on the current text of the Regulation including draft Supplement 30 to the 03 series of amendments. The modifications to the existing text (including draft Supplement 30) of the Regulation are marked in **bold** characters.

A. PROPOSAL

Annex 1,

Sheets H15/1 to 5, amend to read:

" **CATEGORY H15** **Sheet H15/1**

The drawings are intended only to illustrate the essential dimensions (in mm) of the filament lamp

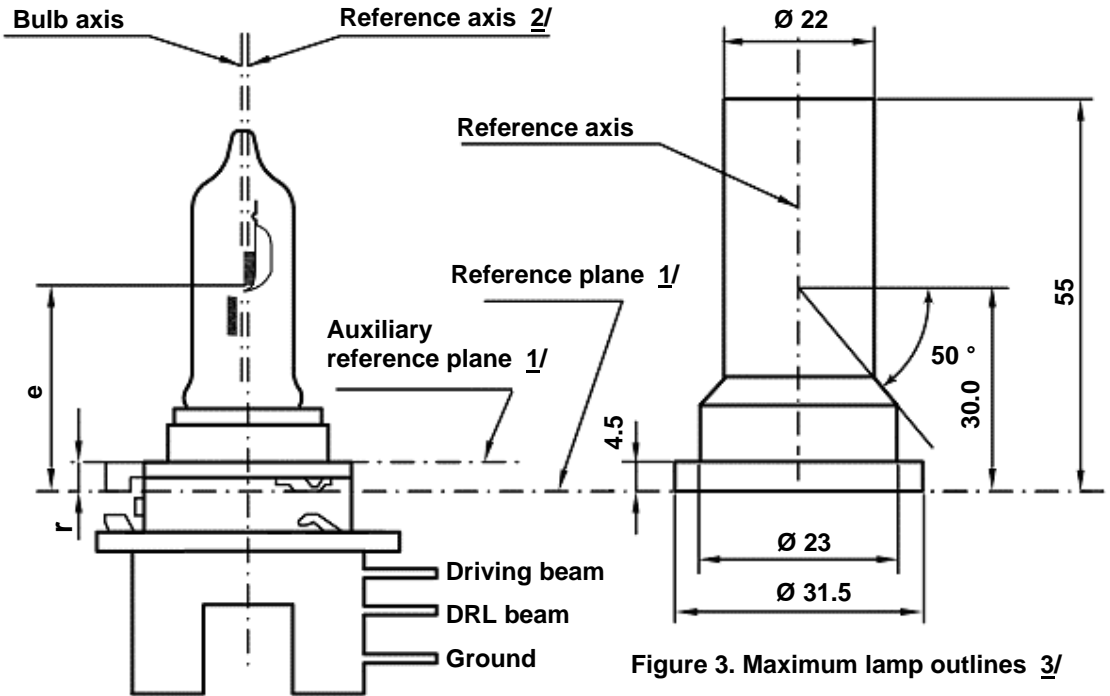

Figure 3. Maximum lamp outlines 3/

Figure 1. Main drawing

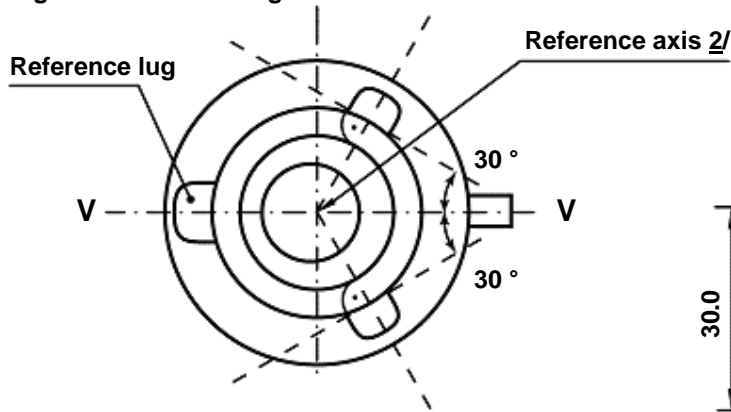

Figure 2. Definition of reference axis 2/

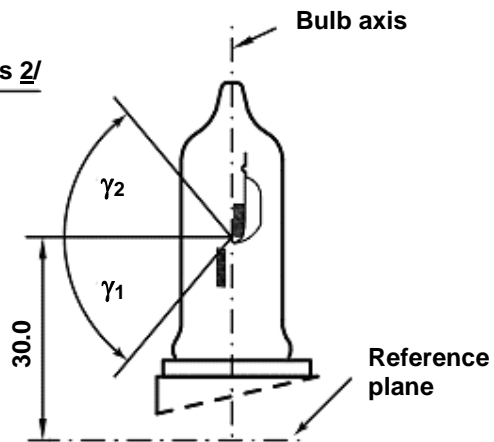

Figure 4. Distortion free area 4/

1/ The reference plane is defined by the points at which the holder touches the three lugs of the cap ring from the plug side. It is intended for use as an internal reference plane.

The auxiliary reference plane is defined by the points on the surface of the holder on which the three supporting bosses of the cap ring will rest. It is intended for use as an external reference plane.

The Cap is designed for use of the (internal) reference plane, but for certain applications the (external) auxiliary reference plane may be used instead.

- 2/ The reference axis is perpendicular to the reference plane and crosses the intersection of the two perpendiculars as indicated in figure 2 on sheet H15/1.
- 3/ Glass bulb and supports shall not exceed the envelope as indicated in figure 3. The envelope is concentric to the reference axis.
- 4/ Glass bulb shall be optically distortion free within the angles γ_1 and γ_2 as indicated in figure 4. This requirement applies to the whole bulb circumference within the angles γ_1 and γ_2 .

CATEGORY H15

Sheet H15/2

Dimensions in mm		Filament lamps of normal production				Standard filament lamp	
		12 V		24 V		12V	
e		30.0 +0.35/-0.25		30.0 +0.35/-0.25		30.0 +0.20/-0.15	
γ_1		50°min		50°min		50°min	
γ_2		50°min		50°min		50°min	
r		For details see cap sheet					
Cap PGJ23t-1 in accordance with IEC Publication 60061 (sheet 7004-155-1)							
ELECTRICAL AND PHOTOMETRIC CHARACTERISTICS							
Rated values	Volts	12 <u>5/</u>		24 <u>5/</u>		12 <u>5/</u>	
	Watts	15	55	20	60	15	55
Test voltage	Volts	13.2		28.0		13.2	13.2
Objective values	Watts	19 max.	64 max.	24 max.	73 max.	19 max.	64 max.
	Luminous flux	260	1,350	300	1,500		
		$\pm 10\%$					
Reference luminous flux at approximately 12 V							1,000
Reference luminous flux at approximately 13.2 V							1,350
Reference luminous flux at approximately 13.5 V						290	

- 5/ The values indicated in the left hand columns relate to the DRL filament. Those indicated in the right hand columns relate to the driving beam filament.

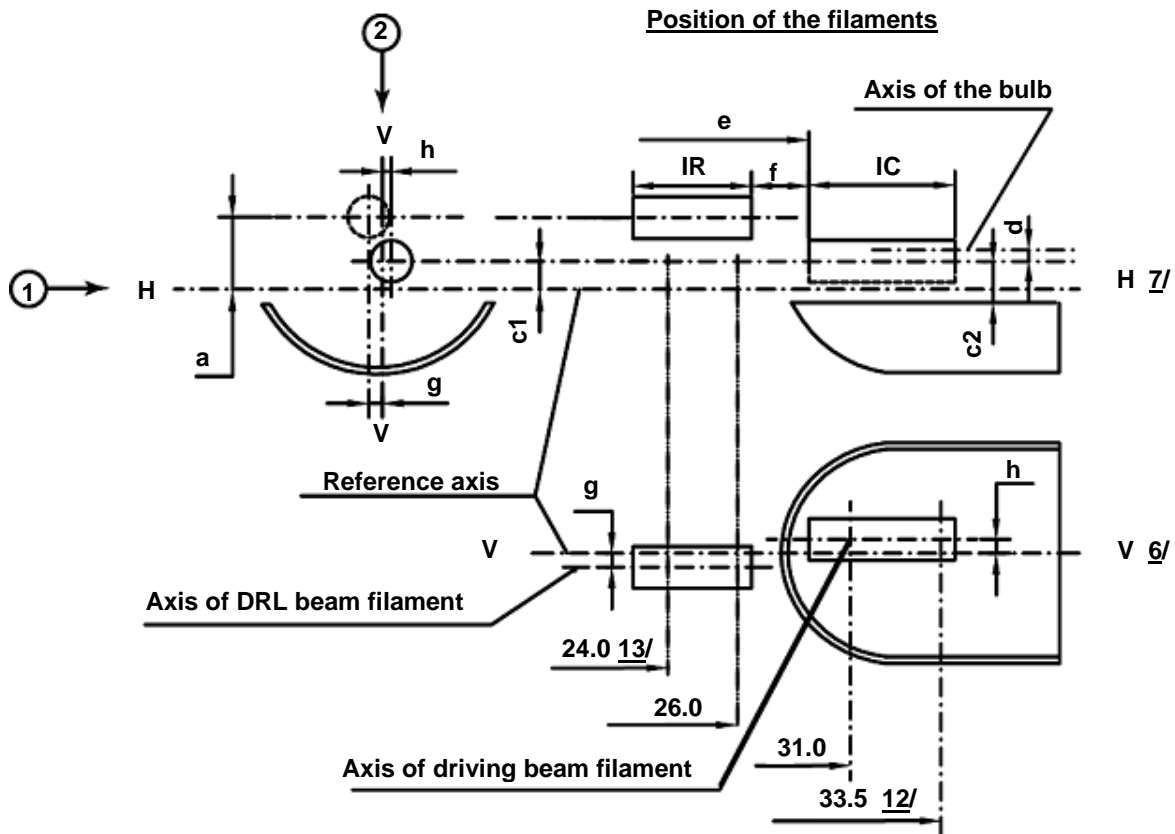
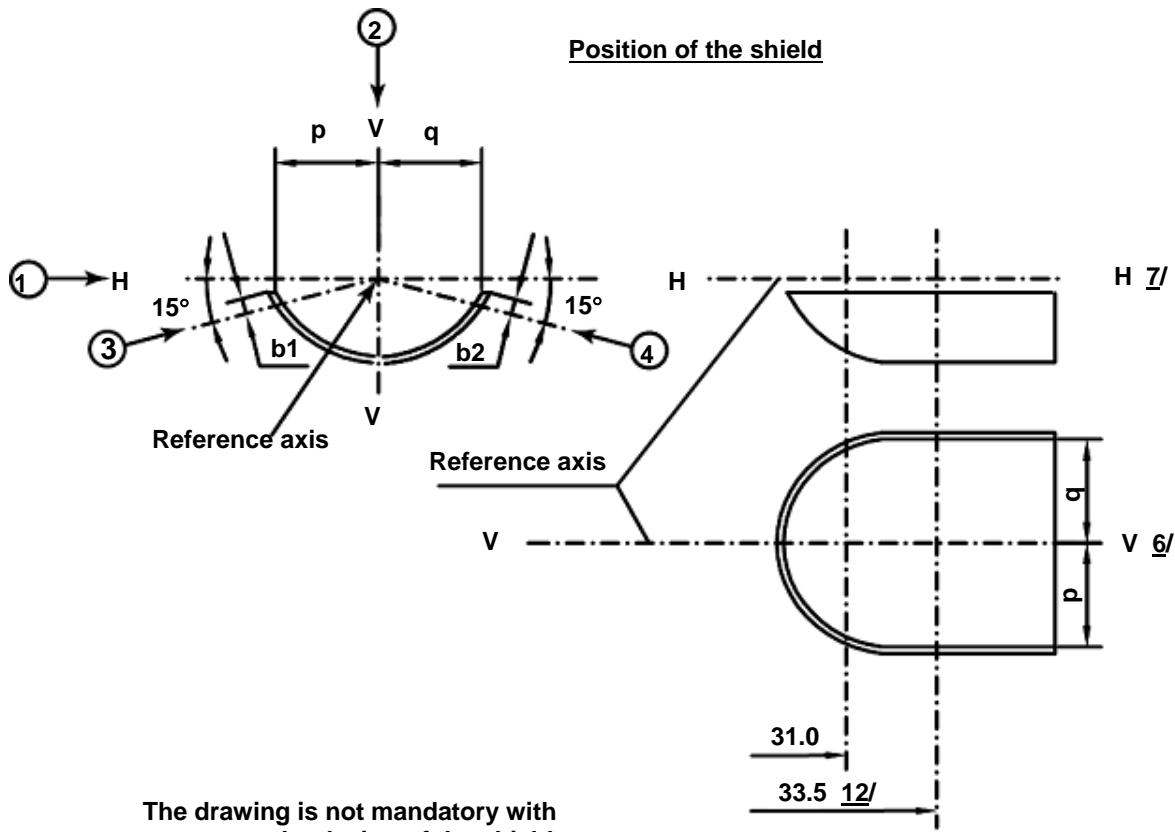

CATEGORY H15

Sheet H15/4

Table of the dimensions (in mm) referred to in the drawings on sheet H15/3

Reference <u>*/</u>		Dimension <u>**/</u>		Tolerance			
				Filament lamps of normal production		Standard filament lamp	
12 V	24 V	12 V	24 V	12 V	24 V	12 V	24 V
a/24.0	a/24.5	1.8		± 0.35		± 0.20	
a/26.0		1.8		± 0.35		± 0.20	
b1/31.0		0		± 0.30		± 0.15	
b1/33.5	b1/34.0	b1/31.0 mv		± 0.30		± 0.15	
b2/31.0		0		± 0.30		± 0.15	
b2/33.5	b2/34.0	b2/31.0 mv		± 0.30		± 0.15	
c1/31.0		0		± 0.30	± 0.50	± 0.15	± 0.25
c1/33.5	c1/34.0	c1/31.0 mv		± 0.30	± 0.50	± 0.15	± 0.25
c2/33.5	c2/34.0	1.1		± 0.30	± 0.50	± 0.15	± 0.25
d		min. 0.1		-		-	
f <u>8/ 9/ 10/</u>		2.7		± 0.30	± 0.40	+ 0.20 - 0.10	+ 0.25 - 0.15
g/24.0	g/24.5	0		± 0.50	± 0.70	± 0.25	± 0.35
g/26.0		0		± 0.50	± 0.70	± 0.25	± 0.35
h/31.0		0		± 0.50	± 0.60	± 0.25	± 0.30
h/33.5	h/34.0	h/31.0 mv		± 0.30	± 0.40	± 0.15	± 0.20
I _R <u>8/ 11/</u>		4.2	4.6	± 0.40	± 0.60	± 0.20	± 0.30
I _C <u>8/ 9/</u>		4.4	5.4	± 0.40	± 0.60	± 0.20	± 0.30
p/33.5	p/34.0	Depends on the shape of the shield		-		-	
q/33.5	q/34.0	p/33.5	p/34.0	± 1.20		± 0.60	

*/ ".../26.0" means dimension to be measured at the distance from the reference plane indicated in mm after the stroke.

**/ "31.0 mv" means the value measured at a distance of 31.0 mm from the reference plane.

- 6/ Plane V-V is the plane perpendicular to the reference plane and passing through the reference axis and through the axis of the reference lug.
- 7/ Plane H-H is the plane perpendicular to both the reference plane and plane V-V and passing through the reference axis.
- 8/ The end turns of the filament are defined as being the first luminous turn and the last luminous turn that are at substantially the correct helix angle.
- 9/ For the driving beam, the points to be measured are the intersections, seen in direction 1, of the lateral edge of the shield with the outside of the end turns defined under footnote 8/.
- 10/ "e" denotes the distance from the reference plane to the beginning of the driving beam filament as defined above.
- 11/ For the DRL filament the points to be measured are the intersections, seen in direction 1, of a plane, parallel to plane H-H and situated at a distance of 1.8 mm above it, with the end turns defined under footnote 8/.
- 12/ 34.0 for the 24 V type.**
- 13/ 24.5 for the 24 V type.**

Additional explanations to sheet H15/3

The dimensions below are measured in four directions:

- 1) for dimensions a, c1, c2, d, e, f, lR and lC;
- 2) for dimensions g, h, p and q;
- 3) for dimension b1;
- 4) for dimension b2.

Dimensions b1, b2, c1 and h are measured in planes parallel to the reference plane at distances of 31.0 mm and 33.5 mm (**34.0 mm for 24 V types**).

Dimensions c2, p and q are measured in a plane parallel to the reference plane at a distance of 33.5 mm (**34.0 mm for 24 V types**).

Dimensions a and g are measured in planes parallel to the reference plane at distances of 24.0 mm (**24.5 mm for 24 V types**) and 26.0 mm."

B. JUSTIFICATION

After the introduction of H15 for 12 V systems (see ECE/TRANS/WP.29/2007/54, approved at the June 2007 session of the World Forum WP.29), it is proposed to include a 24 V version of this light source. This would enable the use of such light sources on motor vehicles with a 24 V board net.
