



**Economic and Social
Council**

Distr.
GENERAL

ECE/TRANS/WP.29/2006/4
12 December 2005

Original: ENGLISH

ECONOMIC COMMISSION FOR EUROPE

INLAND TRANSPORT COMMITTEE

World Forum for Harmonization of Vehicle Regulations (WP.29)
(One-hundred-and-thirty-eighth session, 7-10 March 2006,
agenda item 4.2.11.)

PROPOSAL FOR SUPPLEMENT 4 TO THE 02 SERIES OF AMENDMENTS
TO REGULATION No. 51

(Noise emissions)

Transmitted by the Working Party on Noise (GRB)

Note: The text reproduced below was adopted by GRB at its forty-second session, and is transmitted for consideration to WP.29 and to AC.1 (TRANS/WP.29/GRB/40, paras. 7 and 8). It is based on document TRANS/WP.29/GRB/2005/5, as amended (TRANS/WP.29/GRB/40, Annex 2).

This document is a working document circulated for discussion and comments. The use of this document for other purposes is the entire responsibility of the user.

Documents are also available via the INTERNET:

<http://www.unece.org/trans/main/welcwp29.htm>

Contents of the Regulation, amend to read:

| | <u>Page (s)</u> |
|-----------------|-----------------|
| "1. Scope | 5 |

Part A

2. Definitions

.....

Annex 8 - Specifications for the test site

Part B

1. Definitions

2. Vehicle classification

Annex 1 - Vehicle and test data

Annex 2 - Methods and instruments for measuring the noise made by motor vehicles

Annex 3 - Determination of the wading depth of M_{1d} vehicles"

Text of the Regulation,

Paragraphs 1. and 2., amend to read:

"1. SCOPE

This Regulation applies to vehicles of category M and N 1/ with regard to noise. It contains, in its:

Part A:

provisions relating to the noise emitted by vehicles of category M and N 1/.

1/ As defined in the Consolidated Resolution on the Construction of Vehicles (R.E.3), Annex (documents TRANS/WP.29/78/Rev.1/Amend.2 and Amend.4).

Part B:

a test method intended to reproduce the sound levels, which are generated by vehicles during normal driving in urban traffic. Part B will be applicable once Part A, including the limit values, has been adapted to the new test measurement method contained in Part B.

Part A

2. DEFINITIONS

For the purpose of Part A of this Regulation, "

At the end of the Regulation, insert Part B to read:

"Part B

1. DEFINITIONS

For the purpose of Part B of this Regulation,

1.1. (Reserved)

1.2. "Vehicle type" means motor vehicles which do not differ essentially in such respects as:

1.2.1. the shape or materials of the bodywork (particularly the engine compartment and its soundproofing);

1.2.2. the length and width of the vehicle;

1.2.3. the type of engine (positive or compression ignition, two- or four-stroke, reciprocating or rotary piston), number and capacity of cylinders, number and type of carburettors or injection system, arrangement of valves, rated maximum power and corresponding engine speed(s), or the type of electric motor;

1.2.4. the transmission system, the number of gears and ratios;

1.2.5. the sound reduction system as defined in the following paragraphs 1.3. and 1.4.

1.2.6. Notwithstanding the provisions of paragraphs 1.2.2. and 1.2.4., vehicles other than those in categories M₁ and N₁ ^{1/} having the same type of engine and/or different overall gear ratios, may be regarded as vehicles of the same type.

However, if the above differences provide for a different test method, these differences are to be considered as a change of type.

^{1/} As defined in the Consolidated Resolution on the Construction of Vehicles (R.E.3), Annex (documents TRANS/WP.29/78/Rev.1/Amend.2 and Amend.4).

- 1.3. "Sound reduction system" means a complete set of components necessary for limiting the sound made by a motor vehicle.
- 1.4. "Sound reduction systems of different types" means sound reduction systems which differ in such essential respects as:
- that their components bear different trade names or marks of the manufacturer of the sound reduction system and of its components and the manufacturer's trade description;
 - that the characteristics of the materials constituting a component are different or that the components differ in shape or size. A change in the plating procedure (galvanization, aluminium coating, etc.) is not deemed to produce a difference of type;
 - that the operating principles of at least one component are different;
 - that their components are combined differently;
 - that the number of the intake and/or exhaust silencers is different.
- 1.5. "Sound reduction system component" means one of the individual parts which together form the sound reduction system.
- Such components include, but are not limited to: the intake and exhaust pipes, the expansion chamber(s), the silencer itself, the components of acoustic insulating capsule (screen). Manifolds are not considered component of the sound reduction system.
- 1.6. "Maximum mass" means the technically permissible maximum mass declared by the vehicle manufacturer (this mass may be greater than the maximum mass authorized by the national administration).
- 1.7. "Mass of a vehicle in running order (m_{ro})" means the mass of an unladen vehicle with bodywork, and with coupling device in the case of a towing vehicle, or the mass of the chassis with cab if the manufacturer does not fit the bodywork and/or coupling device, including coolant, oils, 90 per cent of fuel, 100 per cent of other liquids except used waters, tools, spare wheel, driver (75 kg) and, for buses and coaches, the mass of the crew member (75 kg) if there is a crew seat in the vehicle.
- 1.8. "Rated engine power" means the engine power expressed in kW (ECE) and measured by the ECE method pursuant to Regulation No. 85.
- 1.9. "Rated engine speed, S" means the declared engine speed in min^{-1} (rpm) at which the engine develops its rated maximum net power pursuant to Regulation No. 85.
- If the rated maximum net power is reached at several engine speeds, the highest engine speed shall be used.

- 1.10. "Power to mass ratio index (PMR)" means a numerical quantity (see Annex 2 of Part B, paragraph 3.1.2.1.1.) with no dimension used for the calculation of acceleration.
- 1.11. "Reference point" means a point depending on the design and category of the vehicle.
- 1.11.1. Category M_1 , N_1 :
- for front engine vehicles, front end of the vehicle;
 - for mid engine vehicles, centre of the vehicle;
 - for rear engine vehicles, rear end of the vehicle.
- 1.11.2. Category M_2 , M_3 , N_2 , N_3 :
- the border of the engine closest to the front of the vehicle.
- 1.12. "Engine" means the power source without detachable accessories.
- 1.13. "Target acceleration" means an acceleration at a partial throttle condition in urban traffic and is derived from statistical investigations.
- 1.14. "Reference acceleration" means the required acceleration during the acceleration test on the test track.
- 1.15. "Gear ratio weighting factor k" means a dimensionless numerical quantity used to combine the test results of two gear ratios for the acceleration test and the constant speed test.
- 1.16. "Partial power factor k_p " means a numerical quantity with no dimension used for the weighted combination of the test results of the acceleration test and the constant speed test for vehicles.
- 1.17. "Pre-acceleration" means application of acceleration control device prior to AA' for the purpose of achieving stable acceleration between AA' and BB'.
- 1.18. "Locked gear ratios" means the control of transmission such that the transmission gear cannot change during a test.

2. VEHICLE CLASSIFICATION

The following vehicle classification shall be used for the measuring methods described in Annex 2 of Part B:

- 2.1. M_{1a} , are M_1 vehicles with a PMR not exceeding 120. 1/
- 2.2. M_{1b} , are M_1 vehicles with a PMR exceeding 120 and not exceeding 200. 1/
- 2.3. M_{1c} , are M_1 vehicles with a PMR exceeding 200. 1/

- 2.4. M_{1d} , are M_1 vehicles which fulfil the requirements for off-road vehicles 1/ and in addition have a wading depth exceeding 500 mm (see Annex 3 of Part B) and a hill climbing ability equal to or exceeding 35°.
- 2.5. N_{1a} and M_{2a} , are N_1 and M_2 1/ vehicles with a maximum mass not exceeding 2.5 tonnes.
- 2.6. N_{1b} and M_{2b} , are N_1 and M_2 vehicles with a maximum mass exceeding 2.5 tonnes but not exceeding 3.5 tonnes.
- 2.7. M_{2c} , are M_2 vehicles with a maximum mass exceeding 3.5 tonnes.
- 2.8. M_3 1/ vehicles.
- 2.9. N_2 1/ vehicles.
- 2.10. N_{3a} , are N_3 1/ vehicles with a rated engine power not exceeding 300 kW.
- 2.11. N_{3b} , are N_3 vehicles with a rated engine power exceeding 300 kW.

1/ As defined in the Consolidated Resolution on the Construction of Vehicles (R.E.3), Annex (documents TRANS/WP.29/78/Rev.1/Amend.2 and Amend.4).

Annex 1

VEHICLE AND TEST DATA

Information reported in Annex 1 of Part A need not to be repeated.

1. Trade name or mark of the vehicle
2. Vehicle type
- 2.1. Vehicle classification according paragraph 2. of Part B
- 2.2. Water depth (according to Annex 3, if applicable): mm
- 2.3. Maximum mass including semi-trailer (where applicable)
-
3. Manufacturer's name and address
4. If applicable, name and address of manufacturer's representative
-
5. Engine:
 - 5.1. Manufacturer:
 - 5.2. Type:
 - 5.3. Model:
 - 5.4. Rated maximum power (ECE): kW at min⁻¹.
 - 5.5. Kind of engine: e.g. positive-ignition, compression ignition, etc. 2/
.....
 - 5.6. Cycles: two stroke or four-stroke (if applicable)
 - 5.7. Cylinder capacity (if applicable)
6. Transmission: non-automatic gearbox/automatic gearbox 1/
 - 6.1. Number of gears
7. Equipment:
 - 7.1. Exhaust silencer:
 - 7.1.1. Manufacturer or authorized representative (if any)
 - 7.1.2. Model:
 - 7.1.3. Type: in accordance with drawing No.:
 - 7.2. Intake silencer:
 - 7.2.1. Manufacturer or authorized representative (if any)
 - 7.2.2. Model:
 - 7.2.3. Type: in accordance with drawing No.:
 - 7.3. Elements of capsulation
 - 7.3.1. Elements of sound encapsulation as defined by the vehicle manufacturer
 - 7.3.2. Manufacturer or authorized representative (if any)
- 7.4. Tyres
 - 7.4.1. Tyre size(s) (by axle):
8. For vehicles of categories M₂ > 3.5 t, M₃, N₂ and N₃:
 - 8.2.1. Engine speed in gear i at: BB' min⁻¹
 - 8.2.2. Engine speed in gear (i+1) at: BB' min⁻¹

1/ Strike out what does not apply.

2/ If a non-conventional engine is used, this should be stated.

- 8.2.3. Vehicle speed in gear i at: BB' (km/h)
- 8.2.4. Vehicle speed in gear $(i+1)$ at: BB' (km/h)
- 8.3. Type approval number of tyre(s):
if not available, the following information shall be provided:
- 8.3.1. Tyre manufacturer
- 8.3.2. Commercial description(s) of the type of tyre (by axle), (e.g. trade name, speed index, load index):
- 8.3.3. Tyre size (by axle):
- 8.3.4. Type approval number (if available):
- 8.4. Sound level of moving vehicle:
Test result (l_{urban}): dB(A)
Test result (l_{wot}): dB(A)
Test result (l_{cruise}): dB(A)
 k_p – factor:
- 8.5. Sound level of stationary vehicle:
Position and orientation of microphone (according to diagrams in Appendix of Annex 2 of Part B)
Test result for stationary test: dB(A)
- 8.6. Sound level of compressed air sound:
Test result for
-service brake: dB(A)
-parking brake: dB(A)
-during the pressure regulator actuation: dB(A)
9. Vehicle submitted for approval on:
10. Technical service responsible for type-approval tests:
.....
11. Date of test report issued by that service:
12. Number of test report issued by that service:
13. Position of approval mark on the vehicle
14. Place
15. Date
16. Signature
17. The following documents, bearing the approval number shown above, are annexed to this document:
.....
.....
drawings and/or photographs, diagrams and plans of the engine and of the sound reduction system;
list of components, duly identified constituting the sound reduction system.
18. Reason for extension of approval:
19. Remarks

Annex 2

METHODS AND INSTRUMENTS FOR MEASURING THE SOUND
MADE BY MOTOR VEHICLES

1. MEASURING INSTRUMENTS

1.1. Acoustic measurements

The apparatus used for measuring the sound level must be a precision sound - level meter or equivalent measurement system meeting the requirements of class 1 instruments (inclusive of the recommended windscreen, if used). These requirements are described in "IEC 61672-1:2002:Precision sound level meters", second edition, of the International Electrotechnical Commission (IEC).

Measurements shall be carried out using the "fast" response of the acoustic measurement instrument and the "A" weighting curve also described in "IEC 61672-1:2002". When using a system that includes a periodic monitoring of the A-weighted sound pressure level, a reading should be made at a time interval not greater than 30 ms.

The instruments shall be maintained and calibrated in accordance to the instructions of the instrument manufacturer.

1.2. Compliance with requirements

Compliance of the acoustic measurement instrumentation shall be verified by the existence of a valid certificate of compliance. These certificates shall be deemed to be valid if certification of compliance with the standards was conducted within the previous 12 months' period for the sound calibration device and within the previous 24 months' period for the instrumentation system. All compliance testing must be conducted by a laboratory, which is authorized to perform calibrations traceable to the appropriate standards.

1.3. Calibration of the entire acoustic measurement system for measurement session

At the beginning and at the end of every measurement session, the entire acoustic measurement system shall be checked by means of a sound calibrator that fulfils the requirements for sound calibrators of precision class 1 according to IEC 60942: 2003. Without any further adjustment the difference between the readings shall be less than or equal to 0.5 dB. If this value is exceeded, the results of the measurements obtained after the previous satisfactory check shall be discarded.

1.4. Instrumentation for speed measurements

The engine speed shall be measured with instrumentation having an accuracy of ± 2 per cent or better at the engine speeds required for the measurements being performed.

The road speed of the vehicle shall be measured with instrumentation having an accuracy of at least ± 0.5 km/h, when using continuous measurement devices.

If testing uses independent measurements of speed, this instrumentation must meet specification limits of at least ± 0.2 km/h.

1.5. Meteorological instrumentation

The meteorological instrumentation used to monitor the environmental conditions during the test shall include the following devices, which meet at least the given accuracy:

- temperature measuring device, ± 1 °C;
- wind speed-measuring device, ± 1.0 m/s;
- barometric pressure measuring device, ± 5 hPa;
- a relative humidity measuring device, ± 5 per cent.

2. CONDITIONS OF MEASUREMENT

2.1. Test site ^{3/} and ambient conditions

The test site shall be substantially level. The surface of the test track shall be dry. The test site shall be such that when a small omni-directional sound source is placed on its surface at the central point (intersection of the microphone line PP' and the centre line of the vehicle lane CC'), deviations from hemispherical acoustic divergence shall not exceed ± 1 dB.

This condition is deemed to be satisfied if the following requirements are met:

- within a radius of 50 m from the centre of the track the space is free of large reflecting objects such as fences, rocks, bridges or buildings.
- the test track and the surface of the site are dry and free from absorbing materials such as powdery snow, or loose debris.
- in the vicinity of the microphone, there are no obstacle that could influence the acoustical field and no person is positioned between the microphone and the sound source. The meter observer is positioned so as not to influence the meter reading.

^{3/} In conformity with Annex 8 of part A to this Regulation.

Measurements shall not be made under adverse weather conditions. It must be ensured that the results are not affected by gusts of wind.

The meteorological instrumentation should be positioned adjacent to the test area at a height of $1.2 \text{ m} \pm 0.02 \text{ m}$. The measurements shall be made when the ambient air temperature is within the range from 5 °C to 40 °C.

The tests shall not be carried out if the wind speed, including gusts, at microphone height exceeds 5 m/s, during the sound measurement interval.

A value representative of temperature, wind speed and direction, relative humidity, and barometric pressure shall be recorded during the sound measurement interval.

Any sound peak which appears to be unrelated to the characteristics of the general sound level of the vehicle shall be ignored in taking the readings.

The background noise shall be measured for duration of 10 seconds immediately before and after a series of vehicle tests. The measurements shall be made with the same microphones and microphone locations used during the test. The A-weighted maximum sound pressure level shall be reported.

The background noise (including any wind noise) shall be at least 10 dB below the A-weighted sound pressure level produced by the vehicle under test. If the difference between the ambient noise and the measured sound is between 10 and 15 dB(A), in order to calculate the test results the appropriate correction must be subtracted from the readings on the sound-level meter, as in the following table:

| | | | | | | |
|---|-----|-----|-----|-----|-----|-----|
| Difference between ambient noise and noise to be measured dB(A) | 10 | 11 | 12 | 13 | 14 | 15 |
| Correction dB(A) | 0.5 | 0.4 | 0.3 | 0.2 | 0.1 | 0.0 |

2.2. Vehicle

2.2.1. The vehicle shall be representative of vehicles to be put on the market as specified by the manufacturer. Measurements shall be made without any trailer, except in the case of non-separable vehicles. Measurements shall be made on vehicles at the test mass m_t specified according to the following table:

| Vehicle category | Vehicle test mass |
|---------------------------------|---|
| M ₁ | $m_t = m_{ro}$ |
| N ₁ | $m_t = m_{ro}$ |
| N ₂ , N ₃ | <p>$m_t = 50$ kg per kW rated engine power</p> <p>Extra loading to reach the test mass of the vehicle shall be placed above the driven rear axle(s). The extra loading is limited to 75 per cent of the maximum mass allowed for the rear axle. The test mass must be achieved with a tolerance of ± 5 per cent.</p> <p>If the centre of gravity of the extra loading cannot be aligned with the center of the rear axle, the test mass of the vehicle shall not exceed the sum of the front axle and the rear axle load in unladen condition plus the extra loading.</p> <p>The test mass for vehicles with more than two axles shall be the same as for a two-axle vehicle.</p> |
| M ₂ , M ₃ | $m_t = m_{ro} - \text{mass of the crew member (if applicable)}$ |

- 2.2.2. The tyres to be used for the test shall be representative for the vehicle and shall be selected by the vehicle manufacturer and recorded in Annex 1. They shall correspond to one of the tyre sizes designated for the vehicle as original equipment. The tyre is or will be commercially available on the market at the same time as the vehicle ^{4/}. The tyres shall be inflated to the pressure recommended by the vehicle manufacturer for the test mass of the vehicle. The tyres shall have a tread depth of at least 80 per cent of the full tread depth.
- 2.2.3. Before the measurements are started, the engine shall be brought to its normal operating conditions.
- 2.2.4. If the vehicle is fitted with more than two-wheel drive, it shall be tested in the drive which is intended for normal road use.
- 2.2.5. If the vehicle is fitted with fan(s) having an automatic actuating mechanism, this system shall not be interfered with during the measurements.
- 2.2.6. If the vehicle is equipped with an exhaust system containing fibrous materials, the exhaust system is to be conditioned before the test according to Part A, Annex 5.

^{4/} The tyre contribution for overall sound emission being important, this Regulation has taken into account the tyre/road sound emission regulations.

3. METHODS OF TESTING

3.1. Measurement of sound of vehicles in motion

3.1.1. General conditions of test

Two lines, AA' and BB', parallel to line PP' and situated respectively 10 m forward and 10 m rearward of line PP' shall be marked out on the test runway.

At least four measurements shall be made on each side of the vehicle and for each gear. Preliminary measurements may be made for adjustment purposes, but shall be disregarded.

The microphone shall be located at a distance of $7.5 \text{ m} \pm 0.05 \text{ m}$ from the reference line CC' of the track and $1.2 \text{ m} \pm 0.02 \text{ m}$ above the ground.

The reference axis for free field conditions (see IEC 61672-1:2002) shall be horizontal and directed perpendicularly towards the path of the vehicle line CC'.

3.1.2. Specific test conditions for vehicles

3.1.2.1. Vehicles of category M₁, M₂ ≤ 3,500 kg, N₁

The path of the centreline of the vehicle shall follow line CC' as closely as possible throughout the entire test, from the approach to line AA' until the rear of the vehicle passes line BB'. If the vehicle is fitted with more than two-wheel drive, test it in the drive selection which is intended for normal road use.

If the vehicle is fitted with an auxiliary manual transmission or a multi-gear axle, the position used for normal urban driving shall be used. In all cases, the gear ratios for slow movements, parking or braking shall be excluded.

The test mass of the vehicle shall be according to the table of paragraph 2.2.1.

The test speed v_{test} is $50 \text{ km/h} \pm 1 \text{ km/h}$. The test speed must be reached, when the reference point is at line PP'.

3.1.2.1.1. Power to mass ratio index (PMR)

PMR is defined as follows:

$$\text{PMR} = (P_n / m_t) * 1,000 \text{ kg/kW}$$

The power to mass ratio index (PMR) is used for the calculation of acceleration.

3.1.2.1.2. Calculation of acceleration

Acceleration calculations are applicable to M_1 , N_1 and $M_2 \leq 3,500$ kg categories only.

All accelerations are calculated using different speeds of the vehicle on the test track 5/.

The formulas given are used for the calculation of $a_{wot\ i}$, $a_{wot\ i+1}$ and $a_{wot\ test}$. The speed either at AA' or PP' is defined as the vehicle speed when the reference point passes AA' ($v_{AA'}$) or PP' ($v_{PP'}$). The speed at BB' is defined when the rear of the vehicle passes BB' ($v_{BB'}$). The method used for determination of the acceleration shall be indicated in the test report.

Due to the definition of the reference point for the vehicle the length of the vehicle (l_{veh}) is considered differently in the formula below. If the reference point is in the front of the vehicle, then $l = l_{veh}$, mid: $l = \frac{1}{2} l_{veh}$ and rear: $l = 0$.

3.1.2.1.2.1. Calculation procedure for vehicles with manual transmission, automatic transmission, adaptive transmissions and transmissions with variable gear ratios (CVT's) tested with locked gear ratios:

$$a_{wot\ test} = ((v_{BB'}/3.6)^2 - (v_{AA'}/3.6)^2) / (2*(20+l))$$

$a_{wot\ test}$ used in the determination of gear selection shall be the average of the four $a_{wot\ test, i}$ during each valid measurement run.

Pre-acceleration may be used. The point of depressing the accelerator before line AA' shall be reported in the vehicle and test data (Annex 1 of Part B).

3.1.2.1.2.2. Calculation procedure for vehicles with automatic transmissions, adaptive transmissions and CVT's tested with non-locked gear ratios

$a_{wot\ test}$ used in the determination of gear selection shall be the average of the four $a_{wot\ test, i}$ during each valid measurement run.

If devices or measures described in paragraph 3.1.2.1.4.2., can be used to control transmission operation for the purpose of achieving test requirements, calculate $a_{wot\ test}$ using the equation:

$$a_{wot\ test} = ((v_{BB'}/3.6)^2 - (v_{AA'}/3.6)^2) / (2*(20+l))$$

Pre-acceleration may be used.

5/ See Part A, Annex 8, Figure 1.

If no devices or measures described in paragraph 3.1.2.1.4.2. are used, calculate $a_{wot\ test}$ using the equation:

$$a_{wot_testPP-BB} = ((v_{BB}/3.6)^2 - (v_{PP}/3.6)^2) / (2*(10+I))$$

Pre-acceleration shall not be used.

The location of depressing the accelerator shall be where the reference point of the vehicle passes line AA'.

3.1.2.1.2.3. Target acceleration

The target acceleration a_{urban} defines the typical acceleration in urban traffic and is derived from statistical investigations. It is a function depending on the PMR of a vehicle.

The target acceleration a_{urban} is defined by:

$$a_{urban} = 0.63 * \log_{10}(PMR) - 0.09$$

3.1.2.1.2.4. Reference acceleration

The reference acceleration $a_{wot\ ref}$ defines the required acceleration during the accelerated test on the test track. It is a function depending on the power-to-mass ratio of a vehicle. That function is different for specific vehicle categories.

The reference acceleration $a_{wot\ ref}$ is defined by:

$$a_{wot\ ref} = 1.59 * \log_{10}(PMR) - 1.41 \quad \text{for } PMR \geq 25$$

$$a_{wot\ ref} = a_{urban} = 0.63 * \log_{10}(PMR) - 0.09 \quad \text{for } PMR < 25$$

3.1.2.1.3. Partial power factor k_p

The partial power factor k_p (see paragraph 3.1.3.1.) is used for the weighted combination of the test results of the acceleration test and the constant speed test for vehicles of category M_1 and N_1 .

In cases other than a single gear test $a_{wot\ ref}$ has to be used instead of a $a_{wot\ test}$ (see paragraph 3.1.3.1.).

3.1.2.1.4. Gear ratio selection

The selection of gear ratios for the test depends on their specific acceleration potential a_{wot} under full throttle condition, according to the reference acceleration $a_{\text{wot ref}}$ required for the full throttle acceleration test.

Some vehicles may have different software programs or modes for the transmission (e.g. sporty, winter, adaptive). If the vehicle has different modes leading to valid accelerations, the vehicle manufacturer has to prove to the satisfaction of the technical service, that the vehicle is tested in the mode which achieves an acceleration being closest to $a_{\text{wot ref}}$.

3.1.2.1.4.1. Vehicles with manual transmission, automatic transmissions, adaptive transmissions or CVT's tested with locked gear ratios

The following conditions for selection of gear ratios are possible:

- If one specific gear ratio gives an acceleration in a tolerance band of ± 5 per cent of the reference acceleration $a_{\text{wot ref}}$, not exceeding 2.0 m/s^2 , test with that gear ratio.
- If none of the gear ratios give the required acceleration, then choose a gear ratio i , with an acceleration higher and a gear ratio $i+1$, with an acceleration lower than the reference acceleration. If the acceleration value in gear ratio i does not exceed 2.0 m/s^2 , use both gear ratios for the test. The weighting ratio in relation to the reference acceleration $a_{\text{wot ref}}$ is calculated by:

$$k = (a_{\text{wot ref}} - a_{\text{wot (i+1)}}) / (a_{\text{wot (i)}} - a_{\text{wot (i+1)}})$$

- if the acceleration value of gear ratio i exceeds 2.0 m/s^2 , the first gear ratio shall be used that gives an acceleration below 2.0 m/s^2 unless gear ratio $i+1$ provides acceleration less than a_{urban} . In this case, two gears, i and $i+1$ shall be used, including the gear i with acceleration exceeding 2.0 m/s^2 . In other cases, no other gear shall be used. The achieved acceleration $a_{\text{wot test}}$ during the test shall be used for the calculation of the part power factor k_p instead of $a_{\text{wot ref}}$.
- If the vehicle has a transmission in which there is only one selection for the gear ratio the acceleration test is carried out in this vehicle gear selection. The achieved acceleration is then used for the calculation of the part power factor k_p instead of $a_{\text{wot ref}}$.
- If rated engine speed is exceeded in a gear ratio before the vehicle passes BB' the next higher gear shall be used.

3.1.2.1.4.2. Vehicles with automatic transmission, adaptive transmissions and CVT's tested with non-locked gear ratios:

The gear selector position for full automatic operation shall be used.

The acceleration value $a_{\text{wot test}}$ shall be calculated as defined in paragraph 3.1.2.1.2.2.

The test may then include a gear change to a lower range and a higher acceleration. A gear change to a higher range and a lower acceleration is not allowed. A gear shifting to a gear ratio which is not used in urban traffic shall be avoided.

Therefore, it is permitted to establish and use electronic or mechanical devices, including alternate gear selector positions, to prevent a downshift to a gear ratio which is typically not used at the specified test condition in urban traffic.

The achieved acceleration $a_{\text{wot test}}$ shall be greater or equal to a_{urban} .

If possible, the manufacturer shall take measures to avoid an acceleration value $a_{\text{wot test}}$ greater than 2.0 m/s^2 .

The achieved acceleration $a_{\text{wot test}}$ is then used for the calculation of the partial power factor k_p (see paragraph 3.1.2.1.3.) instead $a_{\text{wot ref}}$.

3.1.2.1.5. Acceleration test

The manufacturer shall define the position of the reference point in front of line AA' of fully depressing the accelerator. The accelerator shall be fully depressed (as rapidly as is practicable) when the reference point of the vehicle reaches the defined point. The accelerator shall be kept in this depressed condition until the rear of the vehicle reaches line BB'. The accelerator shall then be released as rapidly as possible. The point of fully depressing the accelerator shall be reported in the vehicle and test data (Annex 1). The technical service shall have the possibility of pretesting.

In the case of articulated vehicles consisting of two non-separable units regarded as a single vehicle, the semi-trailer shall be disregarded in determining when line BB' is crossed.

3.1.2.1.6. Constant speed test

The constant speed test shall be carried out with the same gear(s) specified for the acceleration test and a constant speed of 50 km/h with a tolerance of $\pm 1 \text{ km/h}$ between AA' and BB'. During the constant speed test the acceleration control shall be positioned to maintain a constant speed between AA' and BB' as specified. If the gear is locked for the acceleration test, the same gear shall be locked for the constant speed test.

The constant speed test is not required for vehicles with a PMR < 25 .

3.1.2.2. Vehicles of categories $M_2 > 3,500 \text{ kg}$, M_3 , N_2 , N_3

The path of the centreline of the vehicle shall follow line CC' as closely as possible throughout the entire test, from the approach to line AA' until the rear of the vehicle passes line BB'. The test shall be conducted without a trailer or semi-trailer. If a trailer is not readily separable from the towing vehicle the trailer shall be ignored when

considering the crossing of line BB'. If the vehicle incorporates equipment such as a concrete mixer, a compressor, etc, this equipment shall not be in operation during the test. The test mass of the vehicle shall be according to the table of paragraph 2.2.1.

Target conditions of category $M_2 > 3,500$ kg, N_2 :

When the reference point passes line BB', the engine speed $n_{BB'}$ shall be between 70 per cent and 74 per cent of speed S, at which the engine develops its rated maximum power, and the vehicle speed shall be $35 \text{ km/h} \pm 5 \text{ km/h}$. Between line AA' and line BB' a stable acceleration condition shall be ensured.

Target conditions of category M_3 , N_3 :

When the reference point passes line BB', the engine speed $n_{BB'}$ shall be between 85 per cent and 89 per cent of speed S, at which the engine develops its rated maximum power, and the vehicle speed shall be $35 \text{ km/h} \pm 5 \text{ km/h}$. Between line AA' and line BB' a stable acceleration condition shall be ensured.

3.1.2.2.1. Gear ratio selection

3.1.2.2.1.1. Vehicles with manual transmissions

Stable acceleration condition shall be ensured. The gear choice is determined by the target conditions. If the difference in speed exceeds the given tolerance, then two gears should be tested, one above and one below the target speed.

If more than one gear fulfils the target conditions select that gear which is closest to 35 km/h . If no gear fulfils the target condition for v_{test} two gears shall be tested, one above and one below v_{test} . The target engine speed shall be reached in any condition.

A stable acceleration condition shall be ensured. If a stable acceleration cannot be ensured in a gear, this gear has to be disregarded.

3.1.2.2.1.2. Vehicles with automatic transmissions, adaptive transmissions and transmissions with variable gear ratio (CVT's)

The gear selector position for full automatic operation shall be used. The test may then include a gear change to a lower range and a higher acceleration. A gear change to a higher range and a lower acceleration is not allowed. A gear shifting to a gear ratio which is not used in urban traffic, at the specified test condition, shall be avoided. Therefore, it is permitted to establish and use electronic or mechanical devices to prevent a downshift to a gear ratio which is typically not used at the specified test condition in urban traffic.

If the vehicle includes a transmission design, which provides only a single gear selection (drive), which limits engine speed during the test, the vehicle shall be tested using only a target vehicle speed. If the vehicle uses an engine and transmission combination that does not fulfil paragraph 3.1.2.2.1.1., the vehicle shall be tested using only the target

vehicle speed. The target vehicle speed for the test is $v_{BB'} = 35 \text{ km/h} \pm 5 \text{ km/h}$. A gear change to a higher range and a lower acceleration is allowed after the reference point of the vehicle passes line PP'. Two tests must be performed, one with the end speed of $v_{\text{test}} = v_{BB'} + 5 \text{ km/h}$, and one with the end speed of $v_{\text{test}} = v_{BB'} - 5 \text{ km/h}$. The reported sound level is that result which is related to the test with the highest engine speed obtained during the test from AA' to BB'.

3.1.2.2.2. Acceleration test

When the reference point of the vehicle reaches the line AA' the accelerator control shall be fully depressed (without operating the automatic downshift to a lower range than normally used in urban driving) and held fully depressed until the rear of the vehicle passes BB', but the reference point shall be at least 5 m behind BB'. The accelerator control shall then be released.

In the case of articulated vehicles consisting of two non-separable units regarded as a single vehicle, the semi-trailer shall be disregarded in determining when line BB' is crossed.

3.1.3. Interpretation of results

The maximum A-weighted sound pressure level indicated during each passage of the vehicle between the two lines AA' and BB' shall be noted. If a sound peak obviously out of character with the general sound pressure level is observed, the measurement shall be discarded. At least four measurements for each test condition shall be made on each side of the vehicle and for each gear ratio. Left and right side may be measured simultaneously or sequentially. The first four valid consecutive measurement results, within 2 dB(A), allowing for the deletion of non valid results (see paragraph 2.1.), shall be used for the calculation of the final result for the given side of the vehicle. The results of each side shall be averaged separately. The intermediate result is the higher value of the two averages mathematically rounded to the first decimal place.

The speed measurements at AA', BB', and PP' shall be noted and used in calculations to the first significant digit after the decimal place.

The calculated acceleration $a_{\text{wot test}}$ shall be noted to the second digit after the decimal place.

3.1.3.1. Vehicles of categories M_1 , N_1 and $M_2 \leq 3,500 \text{ kg}$

The calculated values for the acceleration test and the constant speed test are given by:

$$L_{\text{wot rep}} = L_{\text{wot (i+1)}} + k * (L_{\text{wot(i)}} - L_{\text{wot (i+1)}})$$
$$L_{\text{crs rep}} = L_{\text{crs(i+1)}} + k * (L_{\text{crs (i)}} - L_{\text{crs (i+1)}})$$

$$\text{Where } k = (a_{\text{wot ref}} - a_{\text{wot (i+1)}}) / (a_{\text{wot (i)}} - a_{\text{wot (i+1)}})$$

In the case of a single gear ratio test the values are the test result of each test.

The final result is calculated by combining $L_{wot\ rep}$ and $L_{crs\ rep}$. The equation is:

$$L_{urban} = L_{wot\ rep} - k_p * (L_{wot\ rep} - L_{crs\ rep})$$

The weighting factor k_p gives the part power factor for urban driving. In cases other than a single gear test k_p is calculated by:

$$k_p = 1 - (a_{urban} / a_{wot\ ref})$$

If only one gear was specified for the test k_p is given by:

$$k_p = 1 - (a_{urban} / a_{wot\ test})$$

In cases where $a_{wot\ test}$ is less than a_{urban} :

$$k_p = 0$$

3.1.3.2. Vehicles of categories $M_2 > 3,500$ kg, M_3 , N_2 , N_3

When one gear is tested the final result is equal to the intermediate result. When two gears are tested the arithmetic mean of the intermediate results shall be calculated.

3.2. Measurement of sound emitted by stationary vehicles

3.2.1. Sound level in the vicinity of vehicles

In order to facilitate subsequent checks on vehicles in use, the sound level shall be measured close to the exhaust system outlet in accordance with the following requirements and the measurement results entered into the test report drawn up for the purpose of issuing the certificate referred to in Part A, Annex 1.

3.2.2. Acoustic measurements

A precision sound level meter, or equivalent measuring system, as defined in paragraph 1.1. of this annex shall be used for the measurements.

3.2.3. Test site - local conditions (Figure 1)

3.2.3.1. In the vicinity of the microphone, there shall be no obstacle that could influence the acoustical field and no person shall remain between the microphone and the sound source. The meter observer shall be positioned so as not to influence the meter reading.

3.2.4. Disturbance sound and wind interference

Readings on the measuring instruments produced by ambient sound and wind shall be at least 10 dB(A) below the sound level to be measured. A suitable windscreen may be fitted to the microphone provided that account is taken of its effect on the sensitivity of the microphone (see paragraph 1.1. of this annex).

3.2.5. Measuring method

3.2.5.1. Nature and number of measurements

The maximum sound level expressed in A-weighted decibels (dB(A)) shall be measured during the operating period referred to in paragraph 3.2.5.3.2.1.

At least three measurements shall be taken at each measuring point.

3.2.5.2. Positioning and preparation of the vehicle

The vehicle shall be located in the centre part of the test area with the gear selector in the neutral position and the clutch engaged. If the design of the vehicle does not allow this, the vehicle shall be tested in conformity with the manufacturer's prescriptions for stationary engine testing. Before each series of measurements, the engine must be brought to its normal operating condition, as specified by the manufacturer.

If the vehicle is fitted with fan(s) having an automatic actuating mechanism, this system shall not be interfered with during the sound level measurements.

The engine hood or compartment cover, if so fitted, shall be closed.

3.2.5.3. Measuring of sound in proximity to the exhaust (see appendix, Figure 1)

3.2.5.3.1. Positions of the microphone 6/

3.2.5.3.1.2. The microphone shall be located at a distance of $0.5 \text{ m} \pm 0.01 \text{ m}$ from the reference point of the exhaust pipe defined in Figure 1, and at an angle of $45^\circ (\pm 5^\circ)$ to the flow axis of the pipe termination. The microphone shall be at the height of the reference point 1/, but not less than 0.2 m from the ground surface. The reference axis of the microphone shall lie in a plane parallel to the ground surface and shall be directed toward the reference point on the exhaust outlet. If two microphone positions are possible, the location farthest laterally from the vehicle longitudinal centreline shall be used. If the flow axis of the exhaust outlet pipe is at 90° to the vehicle longitudinal centreline, the microphone shall be located at the point, which is farthest from the engine.

3.2.5.3.1.3. For vehicles having an exhaust provided with outlets spaced more than 0.3 m apart, measurements shall be made for each outlet. The highest level shall be recorded.

3.2.5.3.1.4. In the case of an exhaust provided with two or more outlets spaced less than 0.3 m apart and which are connected to the same silencer, only one measurement is made; the microphone position is related to the outlet nearest to one extreme edge of the vehicle or, when such outlet does not exist, to the outlet which is the highest above the ground.

3.2.5.3.1.5. For vehicles with a vertical exhaust (e.g. commercial vehicles) the microphone shall be placed at the height of the exhaust outlet. Its axis shall be vertical and oriented upwards. It shall be placed at a distance of $0.5 \text{ m} \pm 0.01 \text{ m}$ from the exhaust pipe reference point, but never less than 0.2 m from the side of the vehicle nearest to the exhaust.

3.2.5.3.1.6. For exhaust outlets located under the vehicle body, the microphone shall be located a minimum of 0.2 m from the nearest part of the vehicle, at a point closest to, but never less than 0.5 m from the exhaust pipe reference point, and at a height of 0.2 m above the ground, and not in line with the exhaust flow. The angularity requirement in paragraph 3.2.5.3.1.2. may not be met in some cases.

3.2.5.3.2. Operating conditions of the engine

3.2.5.3.2.1. Target engine speed

The target engine speed is defined as:

- 75 per cent of the engine speed S for vehicles with a rated engine speed $\leq 5,000 \text{ min}^{-1}$

6/ See appendix to this annex.

- 3,750 min⁻¹ for vehicles with a rated engine speed above 5,000 min⁻¹ and below 7,500 min⁻¹
- 50 per cent of the engine speed S for vehicles with a rated engine speed $\geq 7,500 \text{ min}^{-1}$.

If the vehicle cannot reach the engine speed as stated above, the target engine speed shall be 5 per cent below the maximum possible engine speed for that stationary test.

3.2.5.3.2.2. Test procedure

The engine speed shall be gradually increased from idle to the target engine speed, not exceeding a tolerance band of ± 3 per cent of the target engine speed, and held constant. Then the throttle control shall be rapidly released and the engine speed shall return to idle. The sound level shall be measured during a period of operation consisting of a maintenance of constant engine speed of 1 second and throughout the entire deceleration period, the maximum sound level meter reading, mathematically rounded to the first decimal place, is taken as the test value.

3.2.5.3.2.3. Test validation

The measurement shall be regarded as valid if the test engine speed does not deviate from the target engine speed by more than ± 3 per cent for at least 1 second.

3.2.6. Results

At least three measurements for each test position shall be made. The maximum A-weighted sound pressure level indicated during each of the three measurements shall be recorded. The first three valid consecutive measurement results, within 2 dB(A), allowing for the deletion of non valid results (see paragraph 2.1. except the specifications of the test site), shall be used for the determination of the final result for the given measurement position. The maximum sound level, for all measurement positions, and of the three measurement results, constitutes the final result.

Annex 2 – Appendix

MEASURING POSITIONS FOR STATIONARY VEHICLES

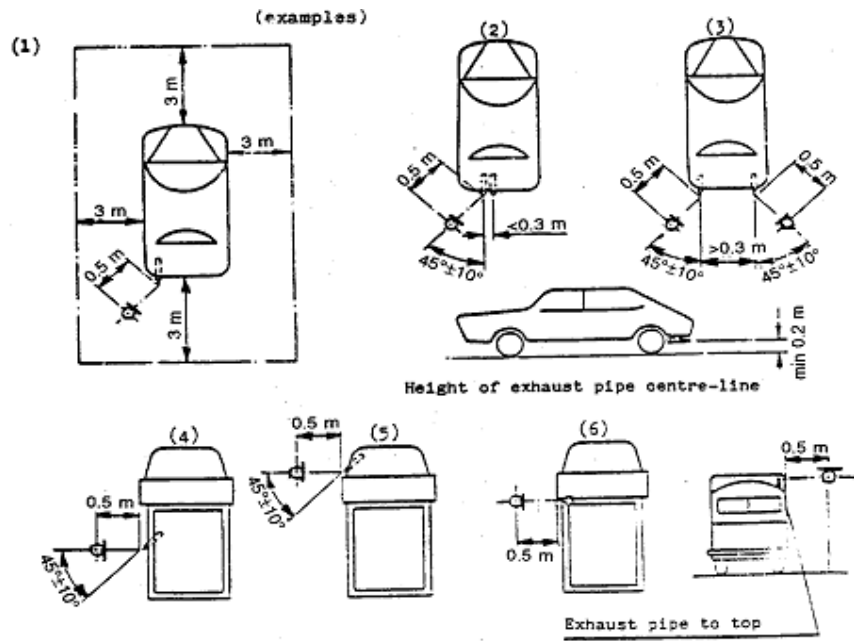

Figure 1

Annex 3

DETERMINATION OF THE WADING DEPTH OF M_{1d} VEHICLES

1. GENERAL

The manufacturer shall prove to the satisfaction of the technical service that a vehicle applying for limits according to paragraph 6.2.2.4. fulfils the requirements as indicated below. The requirements are deemed to be fulfilled, when the basic functions of the vehicle are in operating condition throughout and after the test.

2. TEST CONDITIONS

The vehicle shall cross the basin powered by its own engine. The following conditions for the basin and the test shall be met:

| | |
|--------------------------|-------------|
| Water quality: | fresh water |
| Minimum length of basin: | 20 m |
| Minimum in/out – speed: | 2 km/h |
| Minimum passing speed: | 5 km/h |
| Water depth */: | > 500 mm |

*/ Water depth shall be reported in Annex 1 of Part B"
