

Transmitted by the chairmen of the informal group on pedestrian safety

**PROPOSAL FOR A GLOBAL TECHNICAL REGULATION ON
UNIFORM PROVISIONS CONCERNING THE APPROVAL OF VEHICLES WITH
REGARD TO THEIR CONSTRUCTION IN ORDER TO IMPROVE THE PROTECTION
AND MITIGATE THE SEVERITY OF INJURIES TO PEDESTRIANS AND OTHER
VULNERABLE ROAD USERS IN THE EVENT OF A COLLISION**

Note: The text reproduced below was prepared by the informal group in order to amend and replace TRANS/WP.29/GRSP/2005/3.

**UNITED
NATIONS**



**Economic and Social
Council**

Distr.
~~GENERAL~~

~~TRANS/WP.29/GRSP/2005/3
7 March 2005~~

Original: ~~ENGLISH
ENGLISH AND FRENCH ONLY~~

~~ECONOMIC COMMISSION FOR EUROPE~~

~~INLAND TRANSPORT COMMITTEE~~

~~World Forum for Harmonization of Vehicle Regulations (WP.29)~~

~~Working Party on Passive Safety (GRSP)
(Thirty-seventh session, 23-27 May 2005,
agenda item A.1.)~~

~~PROPOSAL FOR A GLOBAL TECHNICAL REGULATION ON
UNIFORM PROVISIONS CONCERNING THE APPROVAL OF VEHICLES WITH
REGARD TO THEIR CONSTRUCTION IN ORDER TO IMPROVE THE PROTECTION~~

~~AND MITIGATE THE SEVERITY OF INJURIES TO PEDESTRIANS AND OTHER VULNERABLE ROAD USERS IN THE EVENT OF A COLLISION~~

~~Transmitted by the informal group on pedestrian safety~~

~~Note: This document is distributed to the Experts on Passive Safety only.~~

INTRODUCTION

Pedestrian Safety Global Technical Regulation Preamble

A. STATEMENT OF TECHNICAL RATIONALE AND JUSTIFICATION

I. INTRODUCTION

(a) Pedestrian Accident situation and its analysis

Collected road accident statistics indicate that a significant proportion of road casualties are pedestrians and cyclists who are injured as a result of contact with a moving vehicle.

The majority of these injuries are caused by being struck by the front structure of the vehicle. Most of these accidents take place in urban areas where serious or fatal injuries can be sustained at relatively low speed, particularly in the case of children.

The group collected data from IHRA (**International Harmonised Research Agenda**) (INF GR/PS/3 and 31), Germany (INF GR/PS/12, 13 and 25), Italy (INF GR/PS/14), the UN **ECE** (INF GR/PS/15), Spain (INF GR/PS/16), ACEA (INF GR/PS/17), Canada (INF GR/PS/20), the Netherlands (INF GR/PS/21), Sweden (INF GR/PS/41) and Korea (INF GR/PS/70). This data showed that **every year** in the European Union about 8,000 pedestrians and cyclists are killed and about 300,000 injured; in North America around 5,000 pedestrians are killed and 85,000 injured; in Japan 3,300 pedestrians and cyclists are killed and 27,000 seriously injured; in Korea around 3,600 pedestrians are killed and 90,000 injured.

For a detailed analysis, only IHRA/PS can provide full accident study results. The group used the IHRA data as the basis for its study. The data was sourced from Australia, Germany, Japan and the United States.

The following are the IHRA/PS study results.

(i) Distribution of the injuries

Comparing the ages of those involved, statistics show the highest frequency of accidents is for children of 5 to 9 years old, and for adults over 60 years old. Children (aged 15 and under) account for nearly one-third of all injuries in the dataset, even though they constitute only 18 per cent of the population in the four countries included in the IHRA data.

The frequency of fatal and serious injuries (AIS 2-6) is highest for the child and adult head and adult leg body regions.

Each of these body regions covers more than 30 per cent of total accidents and the group believes it should focus on protecting these body regions.

For the vehicle parts, the major sources of adult head injuries are the top surface of bonnet/wing and windscreen area. For the child head injuries, this is the top surface of the bonnet/wing. For the adult leg injury, the major source is the front bumper of vehicles.

(ii) Crash Speeds

Nevertheless, it is considered that there is scope to mitigate the severity of injuries to pedestrians by improving the front structures of motor vehicles. Pedestrian accident data for crash speed between vehicles and pedestrians are collected and the cumulative frequency of the crash speeds shows that a crash speed of up to 40 km/h can cover more than 75 per cent of total pedestrian ~~accidents-injuries~~ in all regions. If a speed of up to 40 km/h is considered, it will significantly reduce the levels of injury sustained by pedestrians involved in frontal impacts with motor vehicles.

(iii) Targeted motor vehicle categories

Clearly the maximum benefit from making vehicles pedestrian friendly would occur if all types of vehicles comply with these technical provisions, but it is recognized that their application to heavier vehicles (large trucks and buses) would be of limited value and may not be technically appropriate in their present form. For this reason, the scope of application will be limited to passenger cars, sport utility vehicles (SUV), light trucks and other light commercial vehicles. Since these vehicle categories represent the vast majority of vehicles currently in use, the proposed measures will have the widest practicable effect in reducing pedestrian injuries.

(b) Other safety measures

The group, taking note of the terms of reference, also considered the issue of other safety measures, such as road infrastructure measures, in addition to passive safety measures on the vehicle itself.

The group recognized that such other active safety measures are not within its field of competence but, at the same time, agreed that such issues should be brought to the attention of WP.29 and AC.3.

As pointed out by several experts, including OICA, pedestrian protection could be considered as a whole, including active and passive measures. Some experts noted that consideration of other safety measures, if properly balanced with the passive safety requirements, might help in ensuring that the vehicle passive safety requirements are kept at a realistic and feasible level.

OICA, in particular, mentioned brake assist systems which can, in emergency situations, substantially improve the braking performance and consequently reduce the impact speed when the impact is unavoidable. A study on the effectiveness of such a system was presented by OICA using the GIDAS (**German In-Depth Accident Studies**) database (INF GR/PS/25). This showed that if the vehicle speed is 50 km/h at the start of braking, the collision speed (car versus pedestrian) would be reduced to 40 km/h in general, to 35 km/h for an experienced driver and to 25 km/h for cars equipped with brake assist systems. Another study performed by the Technical University of Dresden on behalf of ACEA was presented by OICA. This study confirmed the positive effect of brake assist systems on pedestrian fatalities and injuries.

OICA also pointed to the importance of the infrastructure and presented the results of a 1998 study conducted on behalf of ACEA by the consultants ORIENTATIONS (F) and TMS Consultancy (UK) (INF GR/PS/29). This study, which evaluated the effect of infrastructural measures based on real data evaluations, concluded that such measures could dramatically reduce the number of pedestrian victims (fatalities/injuries) at low cost.

While it was agreed that such infrastructure measures were not within the remit of the group, it was agreed that it could be useful and efficient to inform WP.29/AC.3 as well as other authorities of the need to take these issues into account for real world safety improvements. The group also noted the importance of educational measures as well as the need to enforce existing road traffic legislation.

(c) Summary: description of the proposed regulation

Through the pedestrian accidents analysis (mainly IHRA/PS), it has been concluded that child and adult heads and adult legs are the body regions to be most affected by contact with the front end of vehicles.

On vehicles themselves it has been seen that the bonnet top, the windscreen and the A-pillars are the vehicle regions mostly identified with a high potential for contact.

According to the IHRA/PS study, the above-mentioned areas can cover more than 65 per cent of the fatal and serious injuries.

The shape of the vehicle is also considered to be important as it can have an influence on the injury levels. Information on vehicle shapes was also provided by the IHRA/PS group and covered all major regions of the world.

The speed to be considered is presently agreed as 40 km/h to provide good coverage (more than 75 per cent of the pedestrian injured accidents reported by IHRA/PS) of the injury frequency.

The IHRA/PS made an in-depth pedestrian accident study and also collected vehicle front shape figures from the major regions of the world.

Based on these study results, the informal group prioritized the development of the test procedures, and has developed test procedures for adult and child head protection and adult leg protection. To develop these test procedures, IHRA/PS carefully studied the availability of the pedestrian dummy as an alternative method for the test procedures. Presently, there is no test dummy which could be considered suitable and so this group decided to select subsystem test methods which have the necessary reliability, repeatability and simplicity. In addition, there is ready availability of subsystem test impactors.

The group accepted these decisions and agreed on them as the basis for the development of the gtr.

II. PROCEDURAL BACKGROUND

During the one-hundred-and-twenty-sixth session of WP.29 in March 2002, AC.3 concluded their considerations of priorities for developing future global technical regulations. WP.29 adopted the 1998 Global Agreement Programme of Work, which included pedestrian safety, and decided to start the work on pedestrian safety at the thirty-first session of GRSP in May 2002, by creating an informal group to draft the gtr. The formal proposal to develop a gtr (WP.29/AC.3/7) was considered and adopted by the AC.3 at its tenth session, in March 2004. It is based on document

TRANS/WP.29/2004/26, which had been submitted by the European Commission, which is the technical sponsor of the project.

Informal document 10 of the thirty-first session of GRSP lays down the terms of reference of the group and the document was adopted by GRSP (INF GR/PS/2).

Informal document 7 of the thirty-second session of GRSP reported on the result of the first meeting of the informal group (INF GR/PS/9).

Informal document 2 of the thirty-third session of GRSP (INF GR/PS/47 Rev1) was the first preliminary report of the informal group and responds to paragraph 5 of documents TRANS/WP.29/2002/24 and TRANS/WP.29/2002/49 as adopted by AC.3 and endorsed during the one-hundred-and-twenty-seventh session of WP.29. The documents were consolidated in the final document TRANS/WP.29/882. The preliminary report was adopted as WP.29/2003/99 by AC.3 in November 2003.

Informal document 2 of the thirty-fourth session of GRSP reported on the action plan of the informal group (INF GR/PS/62).

Informal document 5 of the thirty-fifth session of GRSP was the second preliminary report of the informal group (INF GR/PS/86 Rev2 and PS/88). This report was considered by AC.3 in June 2004 as informal document WP.29-133-7.

Informal document 1 of the thirty-sixth session of GRSP was the first draft gtr of the informal group (INF GR/PS/116).

The group has held the following meetings:

- 4-5 September, 2002, Paris
- 10 December, 2002, Geneva
- 15-16 January, 2003, Santa Oliva
- 15-16 May, 2003, Tokyo
- 10-12 September, 2003, Ottawa
- 24-26 February, 2004, Paris
- 28-30 September, 2004, Paris
- ~~5-8 April, 2005, Brussels~~ 11-13 July, 2005, Brussels

The meetings were attended by representatives of:

The Netherlands, France, Germany, Canada, EC, Spain, Japan, USA, ~~South~~-Korea, Italy, EEVC, CI, CLEPA and OICA.

The meetings were chaired by Mr. Mizuno (Japan) and Mr. Friedel/Mr. Cesari (EC) whilst the secretariat was provided by Mr. Van der Plas (OICA).

III. EXISTING REGULATIONS, DIRECTIVES, AND INTERNATIONAL VOLUNTARY STANDARDS

At the present time, there are no regulations concerning the provision of improved protection for pedestrians and other vulnerable road users in the Compendium of Candidates.

The following is a summary of work proceeding in this area:

The Japanese Government has established a ~~new~~ regulation on pedestrian protection. The regulation addresses the issues of providing protection for the child and adult heads. It will apply to passenger cars and small trucks with application from 2005 for new vehicle types and from 2010 for existing vehicle types (certain other vehicles have a timetable which is later by two years). The regulation will require compliance with test requirements using representative head impactors.

The European Commission ~~recently~~ adopted the Directive 2003/102/EC which provides for the introduction of requirements for leg injuries, upper leg injuries and adult and child head injuries to be addressed. The ~~proposal~~ Directive and its requirements are incorporated into Community legislation under the European Commission whole vehicle type approval system set up by EU Framework Directive 70/156/EEC, ~~as amended~~. It will apply to passenger cars of category M₁ and to certain light commercial vehicles up to 2,500 kg, with application dates in two phases starting in 2005 and 2010. The second phase, starting in 2010, ~~is presently~~ was the subject of a feasibility study and may be amended as a result.

Canada is currently reviewing their bumper regulation. The Canadian bumper regulation is one of the most stringent in the world (all the safety features of the vehicle have to be functional after an 8 km/h impact). In addition Canada is currently investigating the effect of bumper design on different leg test devices (TRL; Polar and Flexi-PLI). This is being done in two phases with the second phase scheduled to be completed in the summer of 2005.

In the 1980's, NHTSA had ongoing pedestrian protection programmes in two areas:

- (a) pedestrian leg impacts; and
- (b) child and adult pedestrian head and upper body impacts.

NHTSA published an NPRM (**Notice of Proposed Rulemaking**) on improved pedestrian leg protection in 1981 (46 FR 7015). The NPRM proposed to limit the amount of force that could be exerted by a vehicle front structure, particularly the bumper, on an adult pedestrian's leg in a crash. The proposed test requirement involved striking a car (at a speed up to 20 miles per hour (mph)) with a device designed to simulate the impact response of a pedestrian's leg. The NPRM proposed limits on the simulator's impact acceleration response and rebound velocity that were intended to reduce the severity of a pedestrian's injury.

After the 1981 NPRM was published, a trend emerged toward lower passenger car front structures ("profiles"). The pedestrian leg protection rulemaking was terminated in 1991 when NHTSA determined that a bumper that had been identified in the NPRM as providing potential benefit did not in fact reduce the injury severity to the leg when the bumper was installed on

passenger cars with lower profiles. 69 FR 14495; April 10, 1991. "Absent data showing that vehicles that meet the requirements proposed by the NPRM would provide improved protection, the agency has no reason to mandate the soft bumper." (69 FR at 14496.)

Nonetheless, NHTSA's research on pedestrian head and upper body protection continued into the 1990's. The agency developed techniques for simulating pedestrian head impacts on vehicle surfaces. A pedestrian head impact simulator was developed, consisting of a variable mass headform on an impacting ram. Accident reconstruction testing enabled the agency to derive an injury criterion that allowed us to relate an injury criterion to injury severity. NHTSA tested production vehicle hoods, fenders and faces (grilles, headlight areas, leading edges of hoods and fenders) to determine the head injury potential of common vehicle hood, fender and face impact regions, and to understand how specific geometric and/or material characteristics influence injury severity. Research was also conducted to understand how those characteristics could be modified to reduce the severity of head impacts 1/ 2/.

The US pedestrian protection research programme continues today, with much of the effort being supportive of the IHRA objectives. Current activities include (1) pedestrian field data analysis to develop test conditions, (2) evaluation of pedestrian head and leg test tools, (3) experimental impact testing of vehicle structures to assess aggressivity, (4) pedestrian case reconstructions using a combination of field data, computer simulation, and testing to better understand injury mechanisms, (5) computer model development using available biomechanical literature, and (6) completion of other IHRA Pedestrian Safety Working Group (PS WG) action items.

IHRA has developed test procedures for head protection and is considering, as a new step, leg protection requirements. IHRA will be requested to research and report their recommendations to have an improved tool and test procedure for the upper legform to high bumper vehicle test. Additionally, IHRA will be requested to do further research on the upper legform impactor to bonnet leading edge test. This is discussed in detail in sections IV.d.ii. and IV.d.iii.

IV. DISCUSSION OF ISSUES ADDRESSED BY THE GTR

(a) Scope

From the review of pedestrian fatality and injury statistics from several countries, as discussed in the "Introduction" section, it was shown that the head and leg are the most frequently injured body regions. For children, there was a high concentration (36 per cent - INF GR/PS/3 and 31) of head injuries due to contact with the vehicle bonnet/hood. For adults, the injuries were predominately to the head due to contact with the windscreen glass or bonnet/hood (more than 30 per cent, see INF GR/PS/3 and 31), and to the legs due to contact with the bumper (more than 30 per cent, see INF GR/PS/3 and 31). It was agreed that the gtr would encompass tests for the adult head and leg, and the child head. It was also shown by these studies that the majority of

1/ Saul, R.A., Edlefsen, J.F., Jarrett, K.L., Marous, J.R.; "Vehicle Interactions with Pedestrians," Accidental Injury: Biomechanics and Prevention, New York: Springer-Verlag, 2002.

2/ "Report to Congress: Pedestrian Injury Reduction Research," NHTSA Report DOT HS 808 026, June 1993.

pedestrian injuries are occurring in urban environments; therefore the gtr should test those vehicles found in this environment, including passenger vehicles, vans, and light trucks.

There was discussion on whether the proposed pedestrian gtr should regulate passive and/or active safety systems. Active safety systems such as brake assist, anti-lock brakes and day-light running lights were suggested as solutions for the reduction of pedestrian injuries, but it was ultimately counselled by GRSP and WP.29 to concentrate on passive systems for this gtr as this is the main domain of expertise of the GRSP experts and only to provide advice on the use of active systems.

(b) Applicability

Remark: Paragraph needs to be reviewed completely (Action item 5: OICA, ~~YvdS~~).

The application of the requirements of this gtr refers, to the extent possible, to the revised vehicle classification and definitions outlined in the 1998 Global Agreement Special Resolution 1 (SR 1). Difficulties, due to differing existing regulations and divergent vehicle fleets, were encountered in determining which vehicles would be included in the scope. The Japanese regulation applies to passenger cars for up to 10 passengers and commercial vehicles up to a Gross Vehicle Weight (GVW) of 2.5 tonnes which were derived from a passenger car. The IHRA recommends the tests and procedures for passenger vehicles of GVW 2.5 tonnes or less. The European Commission directive applies to M₁ vehicles up to 2.5 tonnes and N₁ vehicles up to 2.5 tonnes which are derived from M₁. The ISO recommendations are for M₁ and N₁ vehicles that have a GVW of 3.5 tonnes or less. Some countries stressed the importance of applying the gtr to light trucks, sport utility vehicles, and vans, in addition to passenger cars.

The shape of the front of the vehicle is important when discussing the types of pedestrian injuries to be mitigated. As discussed earlier, IHRA specifies 3 groups of vehicle shape: sedan, SUV, and 1-box. The gtr system tests have, to date, been developed and validated on the basis of these vehicle shapes. Concern was expressed over the future or other vehicle shapes that may not be represented by the IHRA shapes. [It was agreed that this gtr could only apply, at this stage, to shapes which have been accepted at this stage. If the frontal shape of future vehicle design is not represented by the IHRA shapes, then the gtr will need to be reviewed with reference to any concerns raised as a result.]

There was considerable discussion over the weight of the vehicles to which this gtr should apply. Using the categories described in SR1, there were several options examined. It was agreed that at a minimum the gtr should apply to all vehicles in Category 1-1 with a vehicle weight of less than 2.5 tonnes GVW. An argument for the 2.5 tonnes GVW maximum is that the IHRA tests were only validated for vehicles up to 2.5 tonnes GVW. However, since some Category 1-1 vehicles weigh more than 2.5 tonnes GVW, some delegates argued that the gtr should be applicable to vehicles that weigh up to 3 or 3.5 tonnes GVW. To back up the argument for vehicles weighing more than 2.5 tonnes GVW, it was countered that although the vehicles weigh more, their front end structure is similar to lighter vehicles; and, therefore the application of the requirements should be the same. It was therefore agreed that the gtr would apply to all Category 1-1 vehicles and if a jurisdiction determines that its domestic regulatory scheme is such that full applicability is inappropriate, it may limit domestic regulation to vehicles with a gross vehicle weight of 2.5 tonnes or less.

There was a similar discussion to apply the gtr to Category 1-2 vehicles with a weight of less

than 3.5 tonnes. There are some vehicles in Category 1-2 that have front-end shapes similar to vehicles in Category 1-1, but carry more than 8 passengers. It was argued that since the front-end shape is similar to IHRA vehicle shape categories, the application of requirements should be similar. It was agreed that the gtr would apply to Category 1-2 vehicles weighting 3.5 tonnes or less and if a jurisdiction determines that its domestic regulatory scheme is such that full applicability is inappropriate, it may limit domestic regulation to suit its needs.

Many vehicles in Category 2 are manufactured on the same platform as vehicles in Category 1-1 and have the same or similar front-end shapes, such as pick-up trucks. There was difficulty in defining this group of vehicles. It was suggested that the term "derived from" could be used, as in Category 2 "derived from" Category 1-1, for example, a pick-up truck that is built on the same platform and has the same front-end shape as a passenger car or SUV. This description was unacceptable for some delegates because it is not specific enough. This issue was resolved by limiting the weight of Category 2 vehicles to 3.5 tonnes GVW. By limiting the weight of Category 2 vehicles, the gtr would capture the vehicles that are substantially similar to Category 1 vehicles and do not need to determine how they were derived.

The tests in this gtr are all technically and economically feasible as outlined in section V regulatory impact and economic effectiveness, but it will be the decision of each jurisdiction to determine whether the benefits achieved by requiring these tests justify the costs of the improvements. Based on this determination, a jurisdiction can choose to limit the application in their own regulation to specific vehicle categories. It may also choose to limit the weight of the vehicle to which it applies, and/or it may decide to phase in the regulations over time.

(c) Definitions *(Remark: The whole section needs to be expanded to justify the various test areas considered. (Action new item: OICA, ~~OR~~)*

(i) -Windscreen test area

[PS accident study results included the A-pillar and peripheral area of the windscreen, but due to the difficulty of meeting the requirements using existing technology and not yet having a new technology available to apply in these areas, certain areas of the windscreen were excluded from the requirements.]

(ii) High bumper

The lower leg impactor against the bumper test has some limitations dependent on the bumper height. The contact point between impactor and bumper should be below the knee, due to the impactor's structure/characteristics.

As a result, the test to be used depends on the height of the bumper. For test points above [500] mm, the upper leg to bumper test will be performed and for test points below [500] mm the lower legform to bumper test will be performed.

(d) General Requirements

During the discussions, it became clear that some tests may have their limitations and the group recommended that the following issues should be resolved in the future:

(i) Lower legform impactor

As the FlexPLI is considered by some to have high biofidelity and excellent injury assessment ability, the FlexPLI should be adopted as the sole lower legform impactor for the future. However, because of the lack of experience in using the FlexPLI as a certification tool, a further confirmation process is needed. Therefore, WP.29/GRSP ~~is-was~~ requested to set up a Technical Evaluation Group (TEG). This TEG ~~shall~~will, based on independent studies and relevant information provided by its Members, monitor the reliability of the FlexPLI as a certification tool. The TEG ~~shall-will~~ ~~decide~~-advise GRSP, by a date to be agreed, whether the FlexPLI can be used for testing and compliance verification purposes. The TEG should also propose the effective date of entry into force and the date at which the FlexPLI ~~will~~-could supersede the rigid lower legform impactor. TEG ~~will also propose~~ ~~hea~~ transitional period, during which the FlexPLI and the rigid lower legform impactor can be used as alternatives, ~~shall be [5] years~~.

(ii) Upper legform impactor to high bumper test

Remark: Paragraph needs to be redrafted after final conclusion of the group (Action new item: EU).

The group decided to use EC's tool and test procedure. However, there ~~exists~~-are some concerns about the biofidelity of this tool and requirements.

Therefore, the group requests IHRA/PS to research and report their recommendations to have an improved tool and test procedure for possible future use.

(iii) Upper legform impactor to bonnet leading edge test

Test results using the proposed upper legform to bonnet leading edge prescriptions are contradictory to the actual situation encountered in many real world accidents. This fact, together with the existing concerns on the impact energy, the test tool biofidelity and the injury acceptance levels, caused the group to exclude the test at this stage. However, the group recognizes that this test may have potential value and requests IHRA/PS to carry out further research into the needs and methods for this test. *Remark: Paragraph needs to be expanded with accident data (documents INF GR/PS/30, INF GR/PS/92 and EEVC WG.17 report) (Action new item: OICA, ~~OR~~).*

(iv) *Remark: Add remarks on the systems that change position (pop-up headlamps, headlamp cleaners etc.) (Action new item: OICA, ~~Kin~~)*

(v) *Remark: Add remarks on the test of deployable systems (Action item 15: OICA, ~~Kin~~).*

(e) Performance Requirement

(i) Head Protection

It is important to evaluate the head protection performance because the majority of pedestrian fatalities in road accidents are caused by head injuries. The Head Injury Criteria (HIC) should be used to evaluate the head protection performance. A HIC value of 1000 is equivalent to approximately a 15% ~~per cent~~ risk of AIS 4+ head injury.

As the threshold, a HIC value of [1000] or below is considered appropriate, taking into account the relationship between HIC and AIS. It was agreed, however, that another threshold value could be used for certain limited test areas from a consideration of feasibility (INF GR/PS/94, 102 and 103). *Remark: Paragraph needs to also explain rational for HIC 15 ms (see Dr. Cesari's explanation), the 1/3rd/2/3rd split as well as the HIC1700 (Action item 2 and 6: OICA, ~~KvdP/Kin~~+Dr. Cesari for item 6).*

(ii) Lower Leg Protection

Early accident studies, carried out by Germany, France and the ~~UK~~United Kingdom, have shown that a high proportion of injured pedestrians sustain an injury to the lower leg (i.e. tibia/fibula) or knee. Although there was some variability evident in the trend for the figures, the European Enhanced Vehicle-safety Committee concluded that lower leg and knee injuries are still frequently seen and should be addressed. It was agreed to use the rigid impactor, for the time being, in evaluation of the leg protection performance; however, it was also agreed to consider the possible future use of the Flex-PLI, which is considered by some to be more biofidelic and expected to be highly usable and repeatable, following the evaluation to be conducted by the Technical Evaluation Group (INF GR/PS/106) requested above.

Dynamic cadaver tests have been carried out which showed knee bending angles of 15° and knee shear forces of 3 kN when initial knee damage occurred. An acceptance level for shear loading in the legform test of 4 kN, measured as 6 mm shear displacement, was concluded as a result.

A tibia acceleration level of 150 g was found to indicate a risk for an AIS 2+ lower leg fracture of between 20 per cent and 40 per cent. It was noted that for leg and knee injuries not only the AIS level (i.e. life threatening injuries) should be considered but the long term disability risk should also be taken into account. For car occupants it is recognized that AIS 2 leg injuries show a risk of 15 per cent for permanent disability.

Remark: Delete 2 previous paragraphs above and replace them by the explanation of Dr. Cesari why the limits as mentioned below were chosen. (Action item 3: OICA, ~~KvdP~~)

As a result it was concluded that the acceptance levels for the legform test should be set at:

- a. Maximum lateral knee bending angle \leq ~~{+519.0°}~~;
- b. Maximum lateral knee shearing displacement \leq ~~{6.0}~~ mm;
- c. Maximum lateral tibia acceleration \leq ~~{+50}~~170 g.

Following discussions with interested parties, it was accepted that a phased approach to the introduction of these requirements would be acceptable. Thus, the requirements for phase I of the EU Directive are 21° knee bending angle, 6 mm shear and 200 g acceleration.

For the Flex-PLI, a bending angle of 20 degrees for the knee and a bending moment of 350 Nm for the tibia would be considered appropriate as a threshold. These parameters are equivalent to a 50 per cent risk of knee injury and a mean tibial fracture load, respectively (INF GR/PS/82). The dynamic bending corridors were established by the university of Virginia (INF GR/PS/77). The bio-rating method of Maltese was used to check the FlexPLI biofidelity which proved to range from good to excellent (INF GR/PS/78 and 98).

(iii) Upper leg protection for high bumpers

The legform impactor has limited usage in the testing of vehicles whose bumpers strike the legs above knee level. Accordingly, further discussion is necessary on the appropriate impactor to use for such vehicles. In the meantime, it was decided to use the upper legform impactor. The group decided to copy the requirements from the EU ~~directive~~Directive and set the limits at: ~~{7.5}~~ kN for the impact force and ~~{510}~~ Nm for the bending moment. *Remark: Include the*

explanation of Dr. Cesari (Action item 4: OICA, ~~KvdP~~).

(f) Test Conditions

Remark: Explanation is needed on the absence of a number of tests as well as the absence of the minimum distance between the impact points (Action new item: OICA, ~~PD~~).

(i) Head Protection

Remark: The issue of the undamped accelerometer needs to be mentioned in this section (Action new item: Japan). As head injuries to both adults and children occur throughout a wide range of areas at the front of the vehicle, subsystem tests using the adult and child headform impactors should be performed.

The appropriate headform impactor size and mass, determined based on the characteristics of the human body, are as follows (INF GR/PS/46, 74 and 93):

Headform diameter:

- Child: 165 mm - Due to the fact that the majority of child pedestrian victims are 5 or 6 years old, this value was determined based on the average head diameter of a 6-year-old child (by averaging the diameter obtained from the circumference of the head and the longitudinal and lateral measurements of the head).

- Adult: 165 mm - Although the average diameter of an adult head was also considered, this value was determined based on the diameter of an existing adult headform specified in another regulation. This diameter appears to have been determined based on the diameter of the forehead of an adult male.

Headform mass:

Remark: Add justification for the inertia tolerance level as provided by Dr. Cesari (Action item 9: OICA, ~~KvdP~~).

As computer simulations conducted in the IHRA study show that the effective mass of the head in an impact with vehicles is identical to the actual mass of the head, the headform mass was therefore determined as follows:

- Adult: 4.5 kg - The mass of the head of an adult male (50th percentile adult male - AM50)
- Child: 3.5 kg - The mass of the head of a 6-year-old child

(ii) Lower Leg Protection

As the majority of victims of leg injuries are adults, subsystem tests using legform impactors that simulate adult legs should be performed.

The size and mass of both the present rigid lower legform and the Flex-PLI were determined to be equivalent to those of an adult male (AM50) (INF GR/PS/79).

The results of computer simulation analyses and experimental data indicate that the mass of the upper body need not be taken into consideration for those impacts where the bumper strikes the legs below knee level (INF GR/PS/105).

(iii) Upper leg Protection on high bumpers

As the majority of victims of upper leg injuries are adults, subsystem tests using legform impactors that simulate to upper adult leg should be performed. The impactor specifications are those used in the ~~European~~-EU Directive 2003/102/EC.

(g) Test Procedures

(i) Head Protection (INF GR/PS/58, 61 and 73)

Based on the data of actual accidents, the test area for evaluating the head protection performance should be the front of the vehicle and the windscreen area with a WAD (~~Wrap Around~~ ~~d~~Distance) of 1,000 mm – 2,100 mm. In addition, the test area for adult head injury and that for child head injury should be separated by a boundary. Although an overlap area was also considered with a WAD of 1,400 mm – 1,700 mm where both adults and children have received head injuries in actual accidents, a defined boundary was determined to be more suitable because little difference in the life-saving rate was perceived between the two approaches and the boundary method provided a clearer approach.

The WAD1700 line should be the boundary between the test areas for adult head injuries and child head injuries from a standpoint of maximizing the life-saving rate.

The impact speed of the vehicle was determined to be 40 km/h as specified in the Introduction.

Because the head impact conditions (i.e., speed and angle) are affected by the frontal shape of the vehicle, the test conditions were considered to be determined according to the type of each vehicle's frontal shape. Based on the result of the IHRA's study on the frontal shapes of the vehicles currently in use, vehicle frontal shapes are classified into three types.

Simulations, conducted by JARI (~~Japan a~~Automobile Research Institute), NHTSA and RARU (~~Road Accident Research Unit of Adel~~maide University, carried out as part of the IHRA study showed that the same headform impact speed could be used for any type of vehicle frontal shape and interpretation of the results indicated a speed of 32 km/h, which is 0.8 times the vehicle impact speed. [The acceptance of this test impact speed is still under discussion.] *Remark: Rewrite paragraph and add explanation why head impact speed is 35 km/h (Action new item: OICA, OR/Kin).*

These simulations also indicated that different headform impact angles could be used for each type of vehicle frontal shape. *Remark: Review and add explanation why the EEVC angles were chosen finally. Possibly, also the windscreen impact angle will need justification depending on the final outcome of the discussion (Action item 1 + new item: Dr. Cesari (item 1) + OICA, KvdP).*

In the computer simulations, an adult male model (AM50) and a child model (6-year-old) were used. The impacts were simulated using three types of walking position, three types of vehicle frontal shape and two types of bonnet stiffness as parameters, and the distribution of the headform impact speeds and angles in various impacts was obtained.

(ii) Leg Protection

The impact speed of the legform is the same as that of the vehicle and thus determined to be 40 km/h.

The actual accident data show that the majority of pedestrian accidents occur when the pedestrian crossing the street is struck by the vehicle directly from the side. Therefore, it was decided that the portion of the legform impactor which corresponds to the side of a human leg be impacted with the bumper.

Since pedestrians are usually wearing shoes, the bottom of the legform impactor was determined to be 25 mm above the ground, the same height as the sole of a shoe (INF GR/PS/98).

(iii) Upper leg Protection

The impact speed of the legform is the same as that of the vehicle and thus determined to be 40 km/h.

V. Regulatory Impact and Economic Effectiveness

The group already took note of the feasibility study performed in IHRA (INF GR/PS/5) on the EEVC WG17 proposed head tests. The main conclusions are:

- No vehicle fulfils EEVC/WG17 requirements completely
- No traditional solution currently exists to comply with EEVC/WG17 requirements (not possible with padding only)
- No sensor techniques are available yet to offer other active solutions

The group also checked with various NCAP ([New Car Assessment Programme](#)) programmes around the world to see if data from their tests could give an insight into the feasibility of certain pedestrian tests. Spain presented a study using data from cars tested in EURO-NCAP and compared these with the requirements set out in the first phase of the EU Directive 2003/102/EC on pedestrian protection (INF GR/PS/45). It concluded that, for child headform testing, current vehicles are still far away from being able to meet the proposed requirements. However, simple design changes on the best scoring vehicles will put them in a situation very close to meet the proposed requirements for the first phase of the EU Directive. For the lower legform testing the conclusion was that the majority of vehicles are performing well below the proposed requirements.

Another study was performed by Adelaide University (AUS) (INF GR/PS/66). The study reviewed 50 cars tested by AUS-NCAP and gave the detailed results of all pedestrian tests carried out.

Both ACEA and JAMA have performed their own feasibility studies on the content of the second phase of the EU Directive 2003/102/EC. The ACEA study (INF GR/PS/91) looked at various car types (super mini car, executive car, sport utility vehicle, sports car). They used FE modelling to adapt these models to the Phase 2 requirements and check what the remaining problems are. The results include for each of the types a list of remaining solvable problems and remaining unsolvable problems.

The JAMA study (INF GR/PS/101) looked at the technical feasibility study on EEVC/WG17 pedestrian headform to bonnet top test and on the EEVC/WG17 pedestrian upper legform to bonnet leading edge test. The study concluded, with respect to the headform tests, that a bonnet

hinge complying with the EEVC/WG17 child headform to bonnet top test requirement could be developed but only under the unrealistic condition of removing the fender, and that such a hinge could not satisfy various required performances apart from pedestrian protection performance. As for the upper leg test the study concluded that the test poses serious problems in terms of the impact energy, the test tool in relation to biofidelity, and the injury acceptance levels. Additionally the test is apparently contradictory to the actual situation in a real-world car-pedestrian accident and it is not recommended to use this test in its present form.

In addition, the European Commission made its own feasibility study which was contracted out by TRL (~~UK~~United Kingdom). This feasibility study was required under EU Directive 2003/102/EC (INF GR/PS/89). The study concluded that, although meeting phase two of the Directive might be feasible for some types of vehicles, overall it would be unduly restrictive and is therefore not feasible without some modifications. A number of improvements to the test methods have been identified, the most significant of which are a heavier child headform impactor, revised upper legform test energies and new or reduced tolerances on test conditions. These changes will mean that the protection required will be more appropriate and it is thought that all the changes will make it easier for car manufacturers to achieve compliance. The study also evaluated the manufacturing cost and the estimated annual fatality reduction in the European Union (EU-25). The manufacturing cost to make cars compliant to the proposed amendments was assessed for all car categories and ranges from € 46.92 for a super mini to € 406.61 for a roadster. The estimated annual fatality reduction in the European Union (EU-25) that would be obtained by implementing the suggested amendments was estimated at 1359 pedestrian and pedal cyclists lives saved and 34,305 serious injuries avoided. This would result in an estimated cost benefit ratio of 1 : 5.4 for the introduction of the revised requirements.

Remark: Include Dr. Saul's justification based on IHRA accident data (see document INF GR/PS/131) (Action item 14: US).

Extract from minutes of the 8th meeting: Mr Saul said that for self certification it is going to be very critical to define the relaxation area. Mr Saul presented INF GR / PS / 131 on the analysis of pedestrian accident situation and portion addressed by this gtr. It showed that the hood and fender constitute 41% of the AIS2-6 head injuries. If one takes only the accidents with a speed of 40 km/h, the injuries addressed by the gtr for head testing is about 20% of all child pedestrian head injuries. For adult head injuries the same exercise was made and 12% of adult head injuries. This should be included somewhere in the preamble as it will be very useful for countries that will look at the gtr for adoption at a later stage.

It should, however, be stressed that the available studies on cost/benefit ratio give widely diverging results, such that it is extremely difficult to give a precise estimate of the expected cost/benefit ratio; the GRSP informal group, however, suggests that a gtr containing well balanced and technically feasible test procedures and requirements should result in an adequate cost/benefit ratio. The group also concluded that prospects of global harmonization would ultimately reduce costs even further.

B. ~~_____~~ TEXT OF THE REGULATION

1. PURPOSE AND SCOPE~~7~~

1.1. The purpose of this **global technical** regulation is to bring about an improvement in the construction of the **fronts** of vehicles and, in particular, those areas which have been most frequently identified as causing injury when in collision with a pedestrian or other vulnerable road user. The tests required are limited to those elements of the child and adult body most frequently identified as sustaining injury, i.e. the adult head and leg and the child head. To achieve the required improvements in construction of vehicles, the tests are based on sub-system component impactors representing those body regions and impacted at speeds representative of that below which the majority of injuries occur.

~~1.2.~~ The vehicles to be tested under the regulation are representative of the majority of vehicles in circulation in the urban environment, where there is a greater potential for collision with pedestrians and other vulnerable road users, and include passenger cars, vans and light trucks.

1.2.

2. ~~Application.~~APPLICATION

~~To be rephrased by OICA.~~

~~2.1.— This global technical regulation requires specified tests to be completed for the purpose of qualifying vehicles, including passenger cars, vans and light trucks, with respect to the safety of pedestrians and other vulnerable road users. This global technical regulation (gtr) shall apply to the frontal surfaces of power driven vehicles of category 1-1 with a gross vehicle mass not exceeding 2,5 tonnes, and of category 2 with a gross vehicle mass not exceeding 2,5 tonnes, derived from category 1-1. All definitions of Special Resolution 1 shall apply as necessary.~~

For the purpose of this gtr, vehicles of category -2 derived from category -1-1 means vehicles of category -2 which, forward of the A-pillars, have the same general structure and shape as a pre-existing category -1-1 vehicle.

~~2.2.— This global technical regulation applies to those categories of vehicles as detailed in Table 1 below. All Contracting Parties agreeing to this global technical regulation will indicate, in the table, the vehicle categories and test requirements to be applied in their region.~~

~~— The grey coloured cells of Table 1 indicate for which vehicle category the respective tests are validated. It is depending on the Contracting Parties and their responsibility to select the application of the global technical regulation taking into account the need to validate the test procedure and the requirements for the selected vehicle categories based on the results of studies conducted among others in the framework of EEVC and IHRA.~~

~~— As this will be the final document, it should already be decided what is to be applied by each Contracting Party. It should be hoped that any tests included have been validated for use within the regulation. Thus the following is suggested as a replacement clause.~~

~~[2.2.— This global technical regulation applies to those categories of vehicles as detailed in Table 1 below. For each Contracting Party, the vehicle categories and test requirements to be applied in their region are indicated in the table.]~~

~~2.3.— Regular reviews will be instituted to ensure the eventual application of this global technical regulation to all vehicles in a reduced set of suitable vehicle categories, on the basis of technical and economic feasibility, for all Contracting Parties.~~

~~2.4.— Regular reviews will be instituted to ensure that the specifications of the test requirements will be harmonized into a single set of requirements accepted by all Contracting Parties.~~

~~2.5.— At the time of acceptance of the regulation by any Contracting Party to the regulation, that Contracting Party will be required to accept the alternatives available at that time.~~

~~2.6.— Those tests accepted by any Contracting Party may be phased in with respect to the date of acceptance of the GTR gtr by that Contracting Party. The details of the phasing in periods shall be stated and appended to the regulation~~

This table will provide information on the tests to be applied and the vehicles to which they will be applied in those regions/Contracting Parties entered into the table cells. The categories of vehicle should reflect that which will be agreed under the terms of Special Resolution No. 1 (S.R.1) and may be adjusted to allow the requirements to be applied selectively.

Columns (a) & (b) are as before—allowing a break at the 2,500kg GVM

Column (e) no longer makes reference to ‘derived from’ as this is not a clear recognized category and is not necessary here—there is still the cut-off point at 3,500kg GVM.

Column (d) now reads for the suggested category 2-1 which has a limit of 3,500kg GVM.

The shading is removed from the cells as any test included should be validated before inclusion.

Vehicle Categories						
	(a)	(b)	(c)	(d)	(e)	(f)
Procedure Application	Category 1-1 GVM < 2500 kg	Category 1-1 GVM > 2500 kg	Category 1-2 GVM < 3500 kg	Category 2-1		
child—headform test	Region x Region y Region z	Region y
adult—headform test	Region x Region y	Region z
Legform—to bumper	Region x	Region z	...
Upper legform—to bumper
.....						

Table 1: Agreed Scope and Application for the purposes of this Regulation.

The following notes should now be removed.

[Notes: — Examples of Region: Region x covers all European Member states, Region y covers Japan, Region z covers the US, etc. for other contracting parties.

— The column of tests will continue for each potential agreed alternative test.

— The use of this approach still requires some guidance and approval from WP.29.]

3. ~~DEFINITIONS.~~

All of this next paragraph should be removed from here as the elements are either already contained in or should be inserted under paragraph 6.2

~~When performing measurements on a vehicle as described in this Part, the vehicle should be positioned in its normal ride attitude as described in paragraph 3.20. If the vehicle is fitted with a badge, mascot or other structure which would bend back or retract under a low applied load, then such a load shall be applied before and/or while these measurements are taken. [Any vehicle component which could change shape or position, such as 'pop-up' headlights, other than suspension components or active devices to protect pedestrians, shall be set to a shape or position, [based on a determination by each contracting party or regional economic integration organisation,] considered to be the most appropriate for use on public roads while taking these measurements.]~~

For the purposes of this regulation:

- 3.1. "Adult Headform Test Area" is an area on the outer surfaces of the front structure, as defined in paragraph 3.14.

The area is bounded, in the front, by a wrap around distance of 1700mm, as defined in paragraph 3.31., and, at the rear, by the rear reference line for adult headform, as defined in paragraph 3.21., and, at each side, by the side reference line as defined in paragraph 3.22.

- 3.2. "A-pillar" means the foremost and outermost roof support extending from the chassis to the roof of the vehicle.

~~3.3. "Bonnet angle" shall be the angle, relative to the horizontal plane, of a straight line connecting the points of intersection of the bonnet leading edge reference line and the bonnet rear reference line by a vertical longitudinal plane through the vehicle, at any designated lateral offset from the vehicle centreline. The angle designated by the manufacturer may be accepted as the bonnet angle, if it is within $\pm 2^\circ$ of the actual measurement.~~

Figure 6 could be used to provide an example of the measured angle.

- 3.43. "Bonnet leading edge (BLE)" means the front upper outer structure including the bonnet and wings, the upper and side members of the headlight surrounds and any other attachments. The reference line identifying the position of the bonnet leading edge is defined by its height above the ground reference plane and by the horizontal distance separating it from the bumper (bumper lead), as determined in accordance with paragraphs 3.65, 3.15. and 3.409. respectively.

- 3.54. "Bonnet leading edge height (BLEH)" means the vertical distance between the ground reference plane and the bonnet leading edge reference line, as defined in paragraph 3.65., with the vehicle positioned in its normal ride attitude.

- 3.65. "Bonnet leading edge reference line" means the geometric trace of the points of contact between a straight edge 1000 mm long and the front surface of the bonnet, when the straight edge, held parallel to the vertical longitudinal plane of the car and inclined rearwards by 50° from the vertical and with the lower end 600 mm above the ground, is traversed across and in contact with the bonnet leading edge (~~See-see~~ Figure 1.).

For vehicles having the bonnet top surface inclined at ~~essentially~~ 50°, so that the straight edge makes a continuous contact or multiple contacts rather than a point contact, determine the reference line with the straight edge inclined rearwards at an angle of 40° from the vertical.

For vehicles of such shape that the bottom end of the straight edge makes first contact with the vehicle then that contact is taken to be the bonnet leading edge reference line, at that lateral position.

For vehicles of such shape that the top end of the straight edge makes first contact with the vehicle then the geometric trace of 1000 mm wrap around distance, as defined in paragraph 3.3129., will be used as bonnet leading edge reference line at that lateral position.

The top edge of the bumper shall also be regarded as the bonnet leading edge ~~for this Regulation~~, if it is contacted by the straight edge during this procedure.

- 3.76. "Bonnet rear reference line (BRL)" means the geometric trace of the most rearward points of contact between a 165 -mm diameter sphere and the rear of the bonnet when the sphere is traversed across the bonnet while maintaining contact with the windscreen (see Figure 2.).

Where the bonnet rear reference line and the side reference line do not intersect, the bonnet rear reference line should be extended and/or modified using a semi-circular template, of radius 100 -mm. The template should be made of a thin flexible sheet material that easily bends to a single curvature in any direction. The template should, preferably, resist double or complex curvature where this could result in wrinkling. The recommended material is a foam backed thin plastic sheet to allow the template to "grip" the surface of the vehicle. The template should be marked up with four points "A" through "D", as shown in Figure 3, while the template is on a flat surface.

The template should be placed on the vehicle with Corners "A" and "B" coincident with the side reference line. Ensuring these two corners remain coincident with the side reference line, the template should be slid progressively rearwards until the arc of the template makes first contact with the bonnet rear reference line. Throughout the process, the template should be curved to follow, as closely as possible, the outer contour of the vehicle's bonnet op, without wrinkling or folding of the template. If the contact between the template and bonnet rear reference line is tangential and the point of tangency lies outside the arc scribed by points "C" and "D", then the bonnet rear reference line is extended and/or modified to follow the circumferential arc of the template to meet the bonnet side reference line, as shown in Figure 4.

If the template cannot make simultaneous contact with the bonnet side reference line at points "A" and "B" and tangentially with the bonnet rear reference line, or the point at which the bonnet rear reference line and template touch lies within the arc scribed by points "C" and "D", then additional templates should be used where the radii are increased progressively in increments of 20 -mm, until all the above criteria are met.

3.87. "Bonnet top" is the area which is bounded by (a), (b) and (c) as follows:

- (a) the bonnet leading edge reference line, as defined in paragraph 3.65.;
- (b) the bonnet rear reference line, as defined in paragraph 3.76.;
- (c) the side reference lines, as defined in paragraph 3.2322.

3.98. "Bumper" means the front, lower, outer structure of a vehicle. It includes all structures that are intended to give protection to a vehicle when involved in a low speed frontal collision with another vehicle and also any attachments to this structure. The reference height and lateral limits of the bumper are identified by the corners and the bumper reference lines, as defined in paragraphs 3.12., 3.18., 3.19., 3.2726. and 3.2827.

[3.109. "Bumper lead" for any longitudinal section of a car is the horizontal distance in the vehicle longitudinal plane between the upper bumper reference line, as defined in paragraph 3.2827. and the bonnet leading edge reference line, as defined in paragraph 3.65.]

3.10. "Bumper test area" means the frontal surface of the bumper limited by two longitudinal vertical planes intersecting the corners of the bumper as defined in paragraph 3.12. and moved 66 mm parallel and inboard of the corners of the bumpers.

3.11. "Child Headform Test Area" is an area on the outer surfaces of the front structure, as defined in paragraph 3.14.

The area is bounded, in the front, by the front reference line for child headform, as defined in paragraph 3.13., and, at the rear, by the ~~rear reference line for child headform~~ WAD1700 line, as defined in paragraph ~~3.22.3.3429.~~, and by the side reference lines, as defined in paragraph 3.2322.

3.12. "Corner of bumper" means the vehicle's point of contact with a vertical plane which makes an angle of 60° with the vertical longitudinal plane of the car and is tangential to the outer surface of the bumper (see Figure 5.).

3.13. "Front reference line for Child Headform ~~(CFL)~~" means the geometric trace as described on the vehicle front structure using a ~~wrap around distance of 1,000 mm~~ WAD1000 line as defined in paragraph 3.3429.

In the case of vehicles where the wrap around distance to the bonnet leading edge reference line, as defined in paragraph 3.65., is more than 1,000 mm at any point, then the bonnet leading edge reference line will be used as the front reference line for child headform at that point.

- 3.14. "Front structure" means all parts of the vehicle including the windscreen, the windscreen header, the A-pillars and all parts of the vehicle forward of these. It therefore includes, but is not limited to, the bonnet, wings, scuttle-~~(eowl)~~, wiper spindles, windscreen and lower windscreen frame.
- 3.15. "Ground reference plane" means a horizontal plane, either real or imaginary, that passes through the lowest points of contact for all tyres of a vehicle while the vehicle is in its normal ride attitude. If the vehicle is resting on the ground, then the ground level and the ground reference plane are one and the same. If the vehicle is raised off the ground such as to allow extra clearance below the bumper, then the ground reference plane is above ground level.
- 3.16. "Head Injury Criterion (HIC)" means the calculated result of accelerometer time histories using the following formula:

$$\text{HIC} = \left[\frac{1}{t_2 - t_1} \int_{t_1}^{t_2} a \, dt \right]^{2.5} (t_2 - t_1)$$

Where:

a is the resultant acceleration measured in units of gravity "g"
(1 -g = 9.81 m/s²);

t₁ and t₂ are the two time instants (expressed in seconds) during the impact, defining an interval between the beginning and the end of the recording period for which the value of HIC is a maximum

(t₂ - t₁ ≤ [15] msec)

- 3.17. "Impact point" means the point on the vehicle where initial contact by the test impactor occurs. The proximity of this point to the target point is dependent upon both the angle of travel by the test impactor and the contour of the vehicle surface (see point B in Figure 6.).
- 3.18. "Lower bumper height" means the vertical distance between the ground and the lower bumper reference line, as defined in paragraph 3.19., with the vehicle positioned in its normal ride attitude.
- 3.19. "Lower bumper reference line" means the lower limit to significant points of pedestrian contact with the bumper. It is defined as the geometric trace of the lowermost points of contact between a straight edge 700 -mm long and the bumper, when the straight edge, held parallel to the vertical longitudinal plane of the car and inclined forwards by 25° from the vertical, is traversed across the front of the car, while maintaining contact with the ground and with the surface of the bumper (see Figure 7.).
- 3.20. "Normal ride attitude" means the vehicle attitude ~~when it is at its mass in running order (as defined in Annex 3, paragraph 3 of Special Resolution 1), in driving order positioned on the ground,~~ with the tyres inflated to manufacturer recommended pressures, the front wheels in the straight-ahead position, ~~with maximum capacity of all fluids necessary for~~

~~operation of the vehicle for use on public roads, with all standard equipment as provided by the vehicle manufacturer, with a 75 kg mass placed on the driver's seat, and and -with a 75 kg passenger mass placed on the front passenger seat (as defined in Annex 3, paragraph 6.2. of Special Resolution 1) placed on the front passenger seat. The front seats are placed at the nominal mid-track position, and the suspension shall be set in normal running condition as specified by the manufacturer (especially for vehicles with an active suspension or a device for automatic levelling). Refer to Special Resolution 1 §3 mass in running order and include seat in mid position.~~

3.21. "Rear reference line for Adult Headform (ARL)" means a geometric trace as described on the front structure of the vehicle using a ~~wrap around distance~~ of WAD-2,100 line as defined in paragraph 3.3129.mm.

~~In the case of vehicles where the wrap around distance to the windscreen rear reference line, as defined in paragraph 3.35, is less than 2,100 mm at any point, the rear windscreen reference line will be used as the rear reference line for the adult headform at that point.~~

In the case of vehicles where the wrap around distance of 2,100 mm ~~or the rear windscreen reference line~~, at any point, is above the vertical limit reference line, as defined in paragraph 3.3028, ~~at any point~~, then the vertical limit reference line will be used as the rear reference line for the adult headform at that point.

~~3.22. "Bumper test area" means the frontal surface of the bumper limited by two longitudinal vertical planes intersecting the corners of the bumper as defined in paragraph 3.12. and moved 66 mm parallel and inboard of the corners of the bumpers.~~

~~3.22. "Rear reference line for Child Headform (CRL)" means a geometric trace as described on the vehicle front structure by a wrap around distance of 1700 mm.~~

~~In the case of vehicles where the wrap around distance to the bonnet rear reference line, as defined in paragraph 3.7, is less than 1,700 mm at any point, then the bonnet rear reference line will be used as the rear reference line for the child headform at that point. In case the WAD1700 line, as defined in paragraph 3.31, is located in the windscreen test area, as defined in paragraph 3.36, at any point, the child headform test area is bounded by the WAD1700 line at the rear.~~

3.2322. "Side reference line (SL)" means the geometric trace of the highest points of contact between a straight edge 700 mm long and the sides of the front structure, A-pillars or roof, when the straight edge, held parallel to the transverse vertical plane of the vehicle and inclined inwards by 45° and with the lower end 600 mm above the ground, is traversed down the sides of the front structure, A-pillars or roof, while maintaining contact with the surface of the body shell (see Figure 8.).

3.2423. "Target Point" means the intersection of the projection of the headform longitudinal axis with the front surface of the vehicle (see point A in Figure 6.).

- [3.2524. "Third of the bonnet top" means the geometric trace between the bonnet side reference lines, as defined in paragraph 3.2322., measured with a flexible tape following the outer contour of the bonnet top, divided into three equal parts.]
- [3.2625. "Third of the bumper" means the geometric trace between the corners of the bumper, as defined in paragraph 3.12., measured with a flexible tape following the outer contour of the bumper, divided into three equal parts.]
- [3.2726. "Upper bumper height" means the vertical distance between the ground and the upper bumper reference line, as defined in paragraph 3.2827., with the vehicle positioned in its normal ride attitude.
- [3.2827. "Upper bumper reference line" means the upper limit to significant points of pedestrian contact with the bumper. It is defined as the geometric trace of the uppermost points of contact between a straight edge 700 -mm long and the bumper, when the straight edge, held parallel to the vertical longitudinal plane of the car and inclined rearwards by 20° from the vertical, is traversed across the front of the car, while maintaining contact with the ground and with the surface of the bumper (see Figure 9.). Where necessary the straight edge shall be shortened to avoid any contact with structures above the bumper.]

~~3.29. "Vehicle mass" means the mass of the vehicle in running order, with the maximum capacity of all fluids necessary for the operation of the vehicle, fitted with the standard equipment as provided by the vehicle manufacturer and with no driver or passengers on board.~~

~~This next definition should be removed in line with the requirements of the Table 1. Paragraph numbers are renumbered as a consequence.~~

~~3.31. "Vehicles of category 2 derived from category 1-1" describes vehicles of category 2 which, forward of the A-pillars, have the same general structure and shape as a pre-existing category 1-1 vehicle.~~

3.3028. "Vertical limit reference line (VLL)" means a horizontal line on the vehicle at a vertical height of 1900 mm from the ground reference plane (see Figure- 10.).

3.3129. "Wrap Around Distance (WAD)" is the geometric trace described on the frontal upper surface by one end of a flexible tape, when it is held in a vertical fore and aft plane of the vehicle and traversed across the front ~~surfaces of the bonnet and bumper. structure as defined in paragraph 3.14.~~ The tape is held taut throughout the operation with one end held at ground reference level, vertically below the front face of the bumper and the other end held in contact with the frontal ~~upper surface structure~~ (see Figure 11.). The vehicle is positioned in the normal ride attitude.

This procedure shall be followed, using alternative tapes of appropriate lengths, to describe wrap around distances of 1,000 -mm (WAD1000), of 1,700 -mm (WAD1700) and of 2,100 -mm (WAD2100).

- 3.3230. "Windscreen" means the frontal glazing of the vehicle situated between the ~~—~~A-pillars.
- 3.3331. "Windscreen lower reference line (LWL)"
*to be defined, see Figure 13c. **Definition to be proposed by EC.***
- 3.3432. "Windscreen side reference line (SWL)" is the trace of all points of intersection between the windscreen and a line which is perpendicular to the transverse plane of the vehicle and maintains a lateral offset of 82.5 -mm inside the A-pillars (see Figure 13b.).
- 3.3533. "Windscreen rear reference line (RWL)" is a line parallel to, and at a distance ~~—~~of 82.5 -mm from, the windscreen header, measured on the windscreen surface (see Figure 13a.).
- 3.3634. "Windscreen test area" means an area of the windscreen bordered as follows (see Figure 12.):
- (a) ~~towards the windscreen top,~~ by a line 82.5 mm forward~~s~~ of the windscreen rear reference line~~,~~ as defined in paragraph 3.3533.;
 - (b) ~~towards each windscreen side,~~ by ~~a~~ lines 82.5 mm inside ~~the each~~ windscreen side reference line~~,~~ as defined in paragraph 3.3432.;
 - (c) ~~towards the base of the windscreen,~~ by a line 82.5 mm ~~inside-rearward~~ of the windscreen lower reference line~~,~~ as defined in paragraph 3.3331.

~~—~~ (See Figure 12)

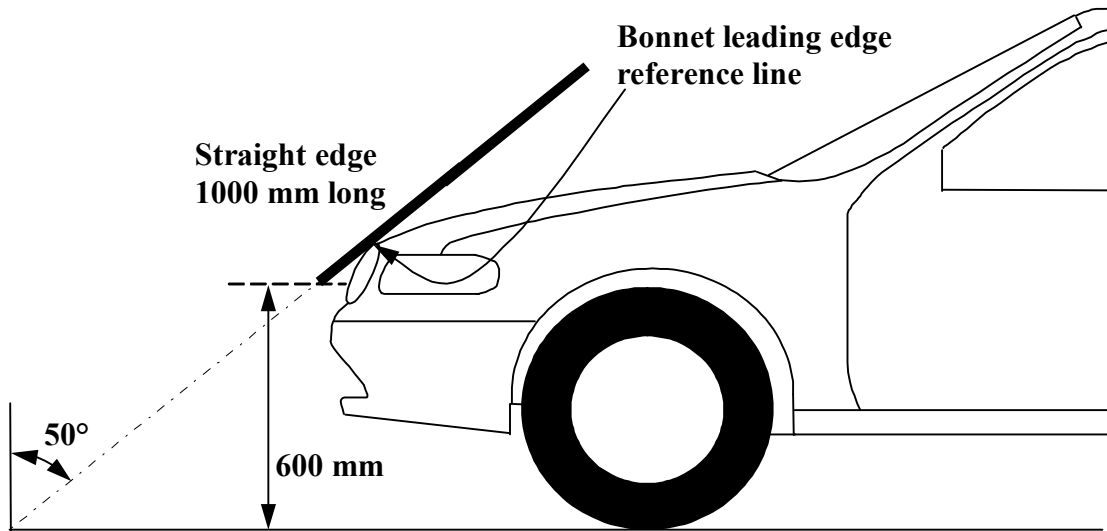

Figure 1: Bonnet ~~Leading-leading Edge-edge Reference-reference Line~~line. (see §paragraph 3.5.)

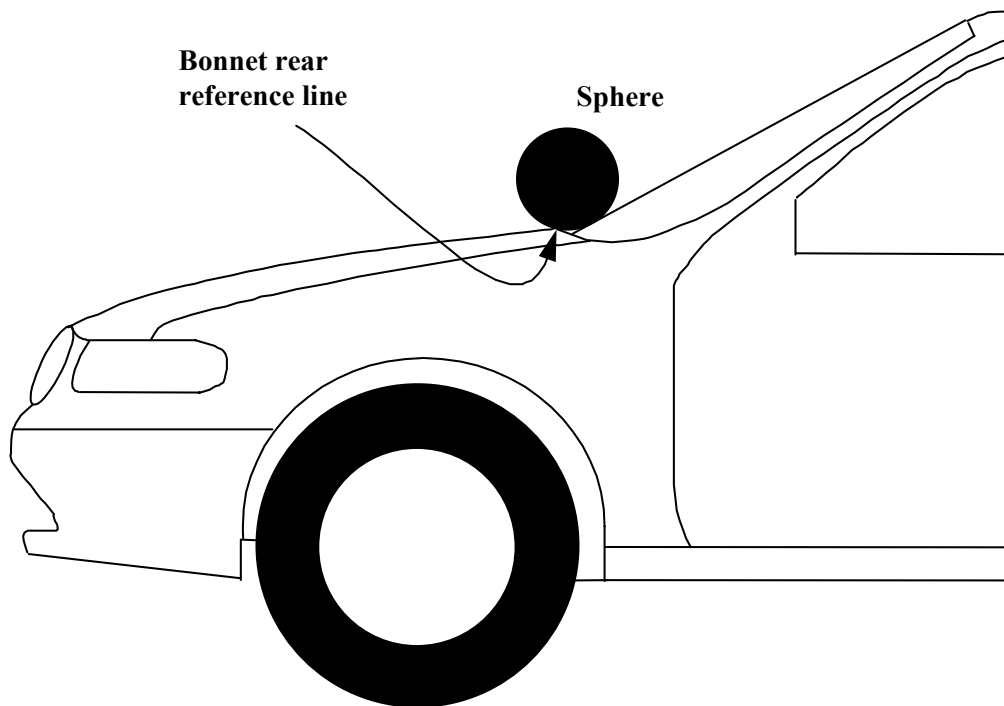

Figure 2: Bonnet ~~Rear-rear Reference-reference Line~~line. (see §paragraph 3.6.)

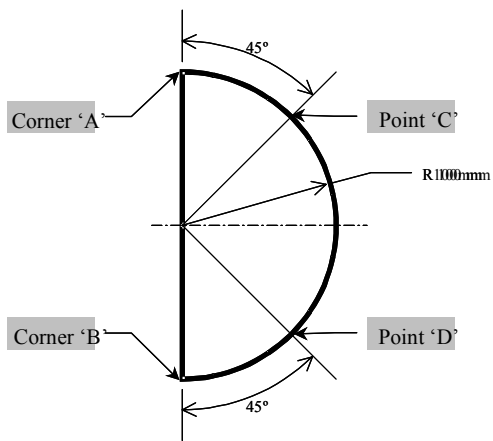

Figure 3: Template. (see §paragraph 3.6.)

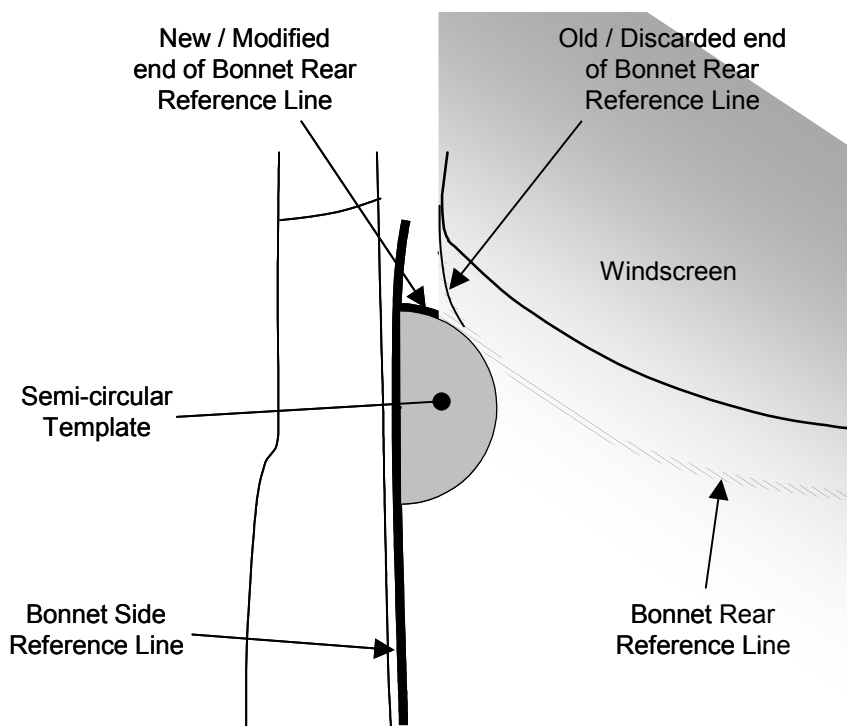

Figure 4: Marking of intersection between bonnet rear and side reference lines.
(see paragraph §3.6.)

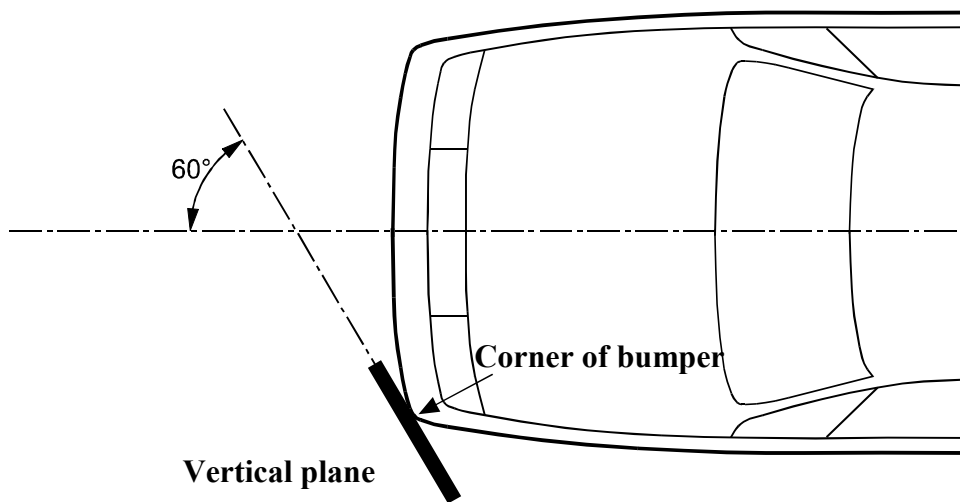

Figure 5: Corner of ~~Bumper~~bumper (see paragraph §3.12.)

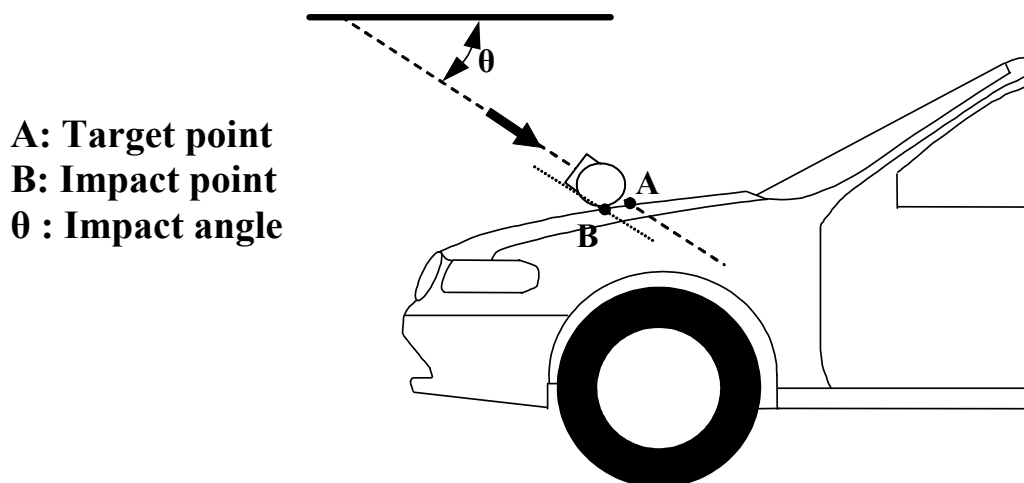
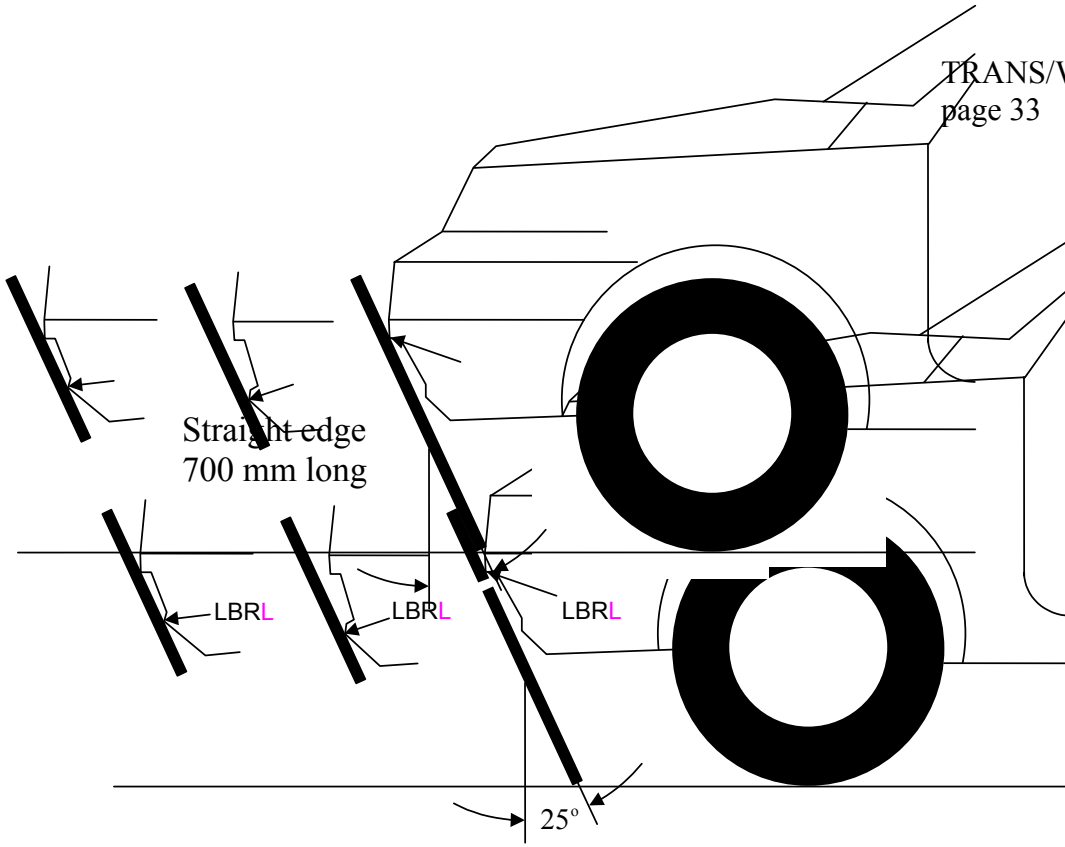

Figure 6: Impact and target ~~Pointpoint~~—(*insertion of impact angle example*) (see paragraph §3.17. and paragraph §3.23.)



2

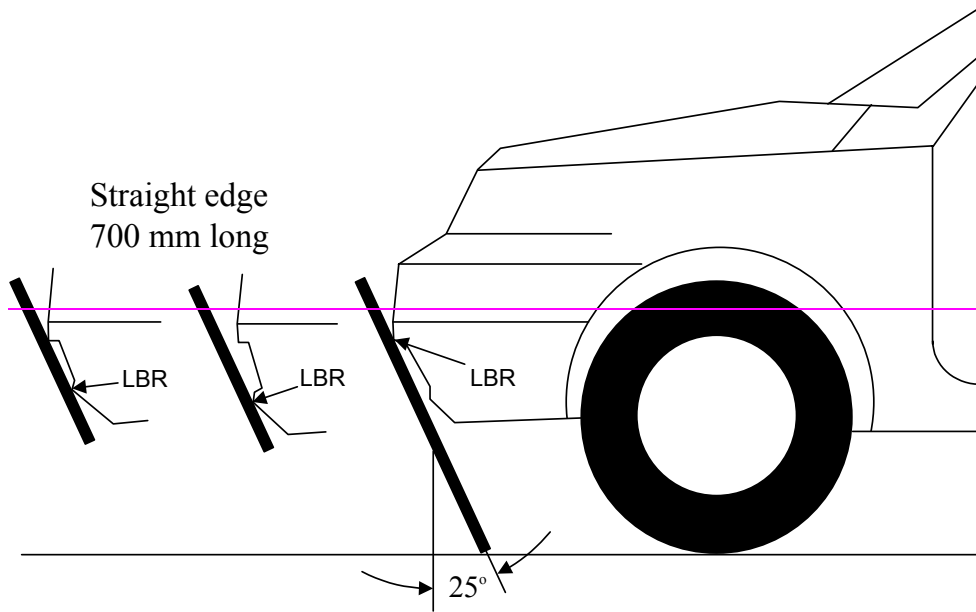

Figure 7: Lower ~~Bumper-bumper Reference-reference Line~~line, LBRL- (see paragraph §3.19.)

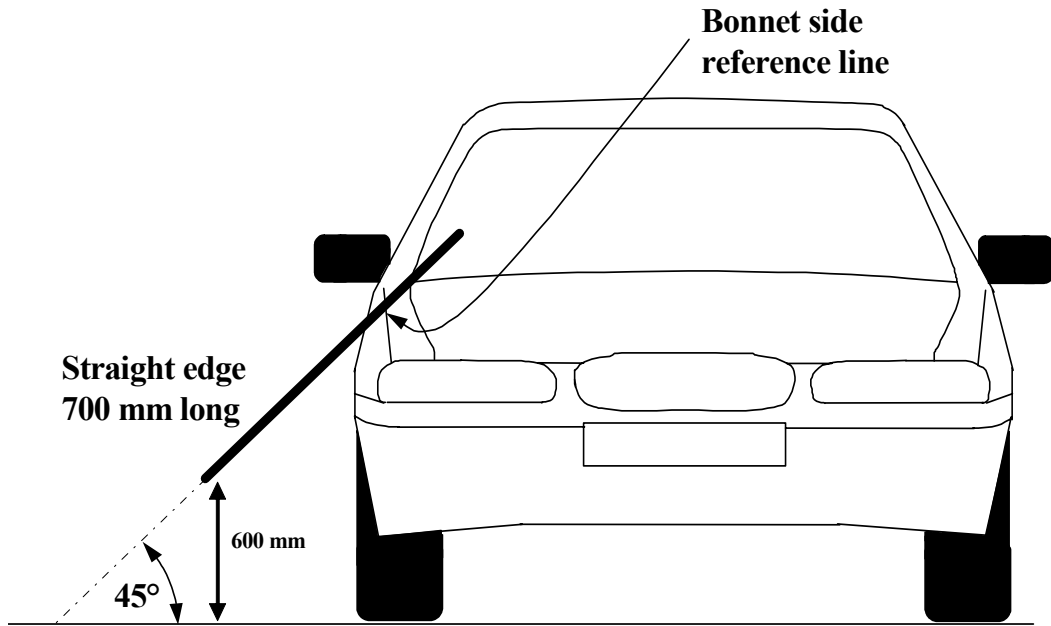
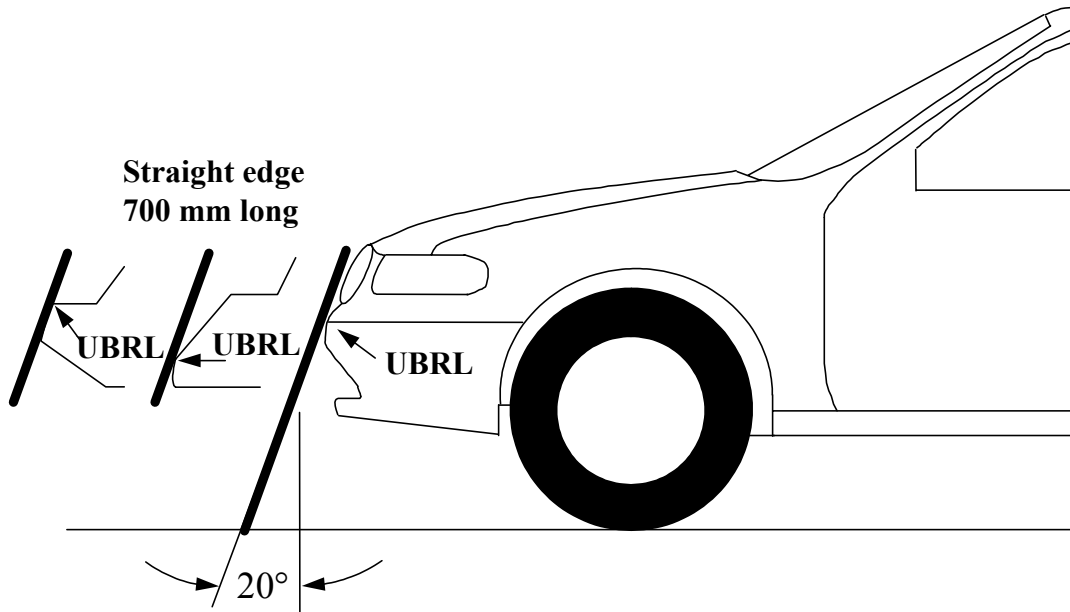

Figure 8: Side ~~Reference-reference~~ ~~Line-~~ (see paragraph §3.22.)



[Figure 9: Upper ~~Bumper-bumper Reference-reference~~ Lineline, UBRL- (see paragraph §3.27.)]

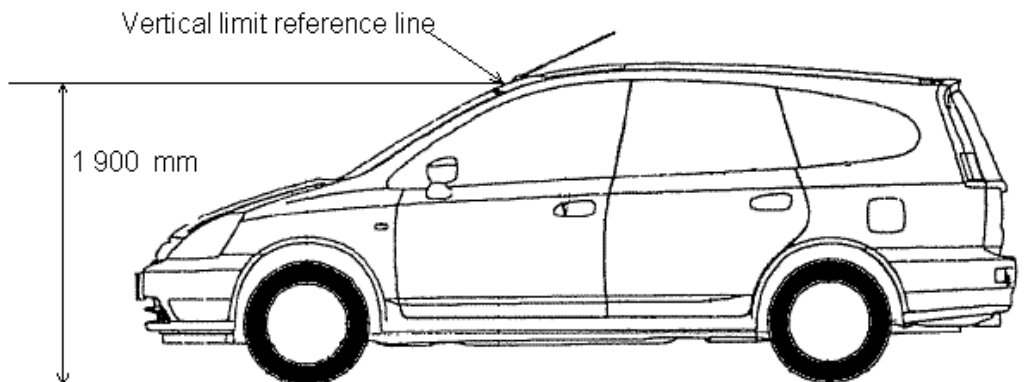

Figure 10: Vertical ~~Limit-limit Reference-reference~~ Lineline- (see paragraph §3.28.)

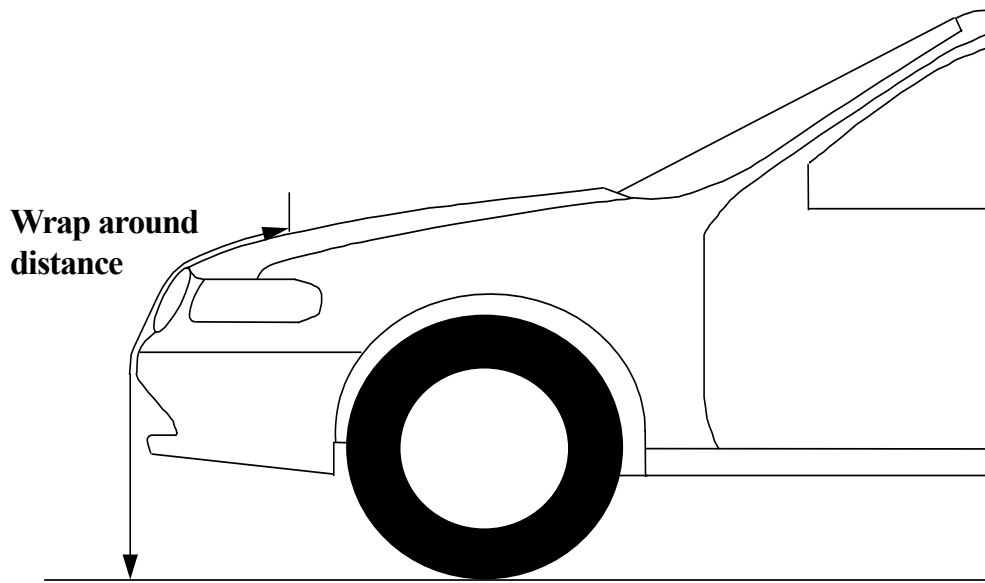

Figure 11: ~~Wrap Around Distance Measurement~~ measurement: (see paragraph §3.29.)

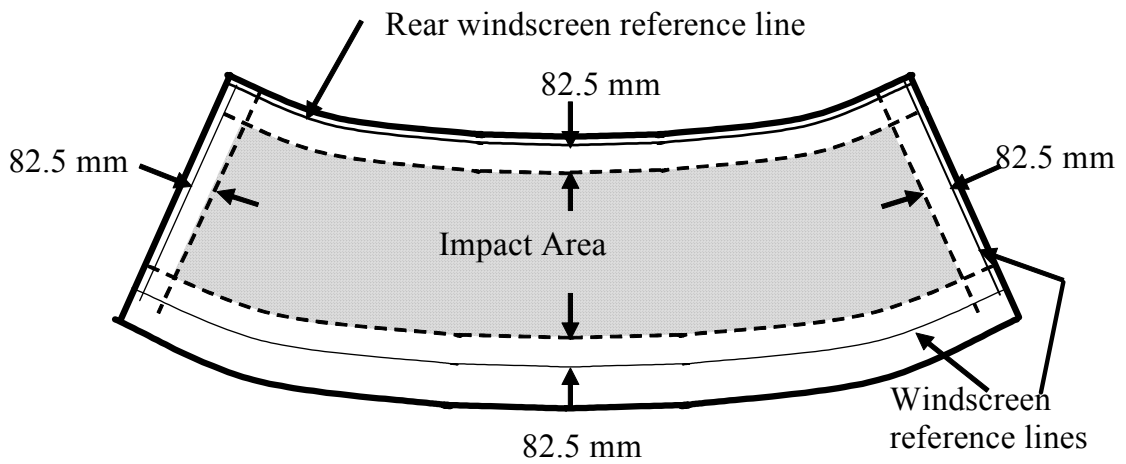

Figure 12: Windscreen test area: (see paragraph §3.34.)

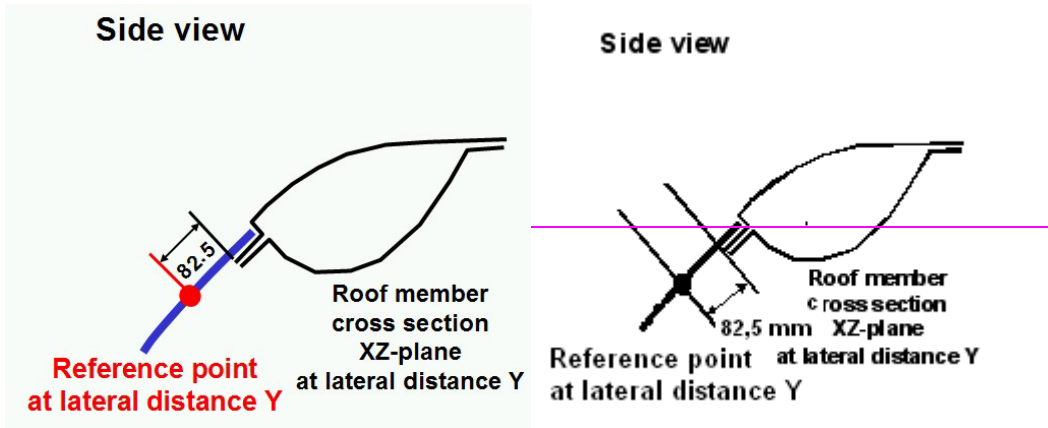

Figure 13a: Windscreen ~~Rear-rear Reference-reference Line~~line (see paragraph §3.33.)
This diagram needs to be changed to reflect definition.

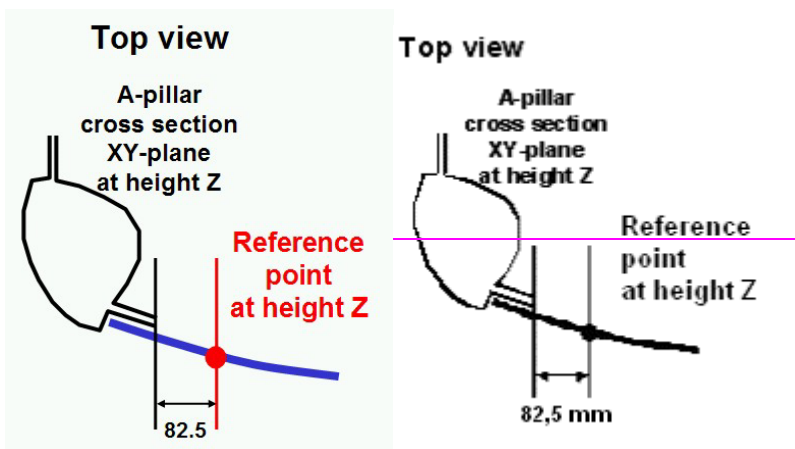

Figure 13b: Windscreen ~~Side-side Reference-reference Line~~line (see paragraph §3.32.)
This diagram needs to be changed to for measurement.

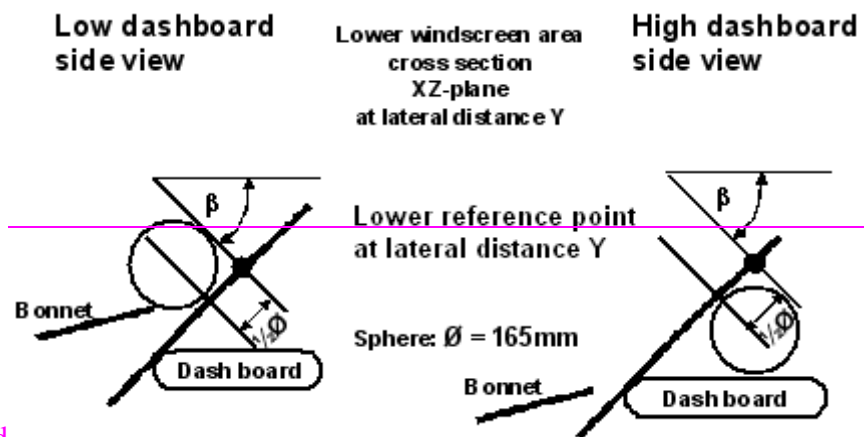

Figure to be created

[Figure 13c: Windscreen ~~Lower-lower Reference-reference Line~~line (see §paragraph 3.31.)
This diagram requires more discussion and agreement.

4. GENERAL REQUIREMENTS-

This ~~Global-global~~ ~~Technical-technical~~ ~~Regulation-regulation~~ specifies the following tests to verify compliance of vehicles.

4.1. Legform test to bumper:

One of the following legform tests ~~are~~ ~~will be~~ required to be performed:

4.1.1. Lower legform to bumper:

To ~~verify the compliance~~ with the performance requirements as specified in paragraph 5.1.1., ~~both~~ the test impactor specified in ~~section-paragraph~~ 6.3.1.1. and the test procedures specified in ~~paragraph section~~ 7.1.1. ~~shall be used~~

4.1.2. Upper legform to bumper:

To ~~verify the comply-compliance~~ with the performance requirements as specified in ~~paragraphsection~~ 5.1.2., ~~both~~ the test impactor specified in ~~paragraphsection~~ 6.3.1.2. and the test procedures specified in ~~paragraphsection~~ 7.1.2. ~~shall be used~~.

4.2. Child headform impact:

To ~~verify the compliance~~ ~~comply~~ with the performance requirements as specified in ~~paragraphssection~~ 5.2.1. and 5.2.3., ~~both~~ the test impactor specified in ~~paragraphsection~~ 6.3.2.1. and the test procedures specified in ~~paragraphssections~~ 7.2 and 7.3. ~~shall be used~~.

4.3. Adult headform impact:

To ~~verify the compliance~~ ~~comply~~ with the performance requirements as specified in ~~paragraphssection~~ 5.2.2. and 5.2.3., ~~both~~ the test impactor specified in ~~paragraph~~ 6.3.2.2. and the test procedures specified in ~~paragraphssections~~ 7.2. and 7.4. ~~shall be used~~.

~~4.4. All tests shall comply with the requirements of the general site conditions specified in paragraphsection 6.1. and vehicle preparation requirements specified in paragraphsection 6.2.~~

5. ~~PERFORMANCE REQUIREMENTS-~~

5.1. Legform to Bumper:

5.1.1. When tested in accordance with ~~paragraphsection~~ 7.1.1. (lower legform to bumper), the maximum dynamic knee bending angle shall not exceed ~~{21.0°19°}~~, the maximum dynamic knee shearing displacement shall not exceed ~~{6.0 mm}~~, and the acceleration measured at the upper end of the tibia shall not exceed ~~{200-170 g}~~. [In addition the manufacturer may nominate bumper test widths up to 264 mm in total where the acceleration measured at the upper end of the tibia shall not exceed 250 g.]

5.1.2. When tested in accordance with ~~paragraphsection~~ 7.1.2. (~~Upper-upper~~ legform to bumper), the instantaneous sum of the impact forces with respect to time shall not exceed ~~—{7.5 kN}~~ and the bending moment on the test impactor shall not exceed ~~{510 Nm}~~.

5.2. Headform tests

5.2.1. Child headform to front structure:

When tested in accordance with ~~paragraph~~~~section~~ 7.3. [for all tests, together with the tests according to paragraph 5.2.2,] the HIC shall not exceed 1000 over [2/3] of the bonnet test area and [1700] for the remaining [1/3] [of the bonnet test area]. ~~the Head Injury Criterion (HIC) shall not exceed [1,000] over the child headform test area which falls within the bonnet top.~~ For impact points in the windscreen test area, the requirements of paragraph 5.2.3. shall apply.

5.2.2. Adult headform to the front structure:

When tested in accordance with ~~paragraph~~~~section~~ 7.4. [for all tests , together with the tests according to paragraph 5.2.1,] the HIC shall not exceed 1000 over [2/3] of the bonnet test area and [1700] for the remaining [1/3] [of the bonnet test area]. ~~the Head Injury Criterion (HIC) shall not exceed [1,000] over the adult headform test area which falls within the bonnet top.~~ For impact points in the windscreen test area, the requirements of paragraph 5.2.3. shall apply.

5.2.3. ~~If the tested front structure as impacted by the child or adult headforms includes parts of the windscreen, as defined in paragraph 3.32.,~~ The Head Injury Criterion (HIC) shall not exceed [1,000] for ~~all the~~any selected ~~impact~~ impact points within the windscreen test area, ~~as defined in paragraph 3.33.~~

6. ~~TEST SPECIFICATIONS~~

6.1. General ~~Site test Conditions~~conditions

6.1.1. Temperature and humidity

The stabilized temperature of the test tools and of the vehicle or sub-system at the time of testing shall be ~~{20° ± 4°}C~~. The relative humidity of the test area where all equipment is ~~held stored~~ should be ~~{10 to 70}~~ per cent after a stabilized period of at least four hours prior to the application of any test.

~~6.1.1.1. Sufficient time must be allowed before testing for the temperature of all vehicle components to stabilize to the required temperature range.~~

~~6.1.1.2. Relative humidity and temperature shall be measured at the time of the test, and recorded in the test report.~~

6.1.2. Impact test site

The test site shall consist of a flat, smooth and hard surface with a slope not exceeding 1 per cent.

6.2. Preparation of the vehicle

6.2.1. Either a complete vehicle, or a cut-body, adjusted to the following conditions shall be used for the test.

6.2.1.1. The vehicle shall be in its normal ride attitude, as described in paragraph 3.20., and shall be either securely mounted on raised supports or at rest on a flat surface. The parking brake shall be applied, or the cut-body shall be securely mounted.

6.2.1.2. The cut-body shall include all parts of the vehicle front structure and under bonnet components, or behind windscreen components, that may be involved in a frontal impact with a vulnerable road user in the test, to demonstrate the performance and interactions of all the contributory vehicle components.

~~6.2.1.2.1. —~~The cut-body shall be securely mounted in the normal vehicle ride attitude.

6.2.2. All devices designed to protect vulnerable road users **when impacted by the vehicle** shall be correctly activated before and/or be active during the appropriate test. **An example of a typical procedure is as specified described in Annex 1.** -It shall be the responsibility of the manufacturer to show that any devices will act as intended in a pedestrian impact.

~~6.2.3. Any vehicle component which could change shape or position, such as ‘pop-up’ headlights, other than active devices to protect pedestrians, shall be set to a shape or position that the test institutes in consultation with the manufacturer consider to be the most appropriate for these tests.~~

6.2.3. For vehicle components which could change shape or position, other than active devices to protect pedestrians, where such devices have more than one fixed position the vehicle shall comply with all requirements for all of these positions. Where such devices have only one fixed position, only the fixed position shall be considered.

6.2.4. If the vehicle is fitted with a badge, mascot or other structure which would bend back or retract under a low applied load, then such a load shall be applied before and/or while the test requirements are completed.

6.3. Test impactor specifications

6.3.1. Legform impactors:

6.3.1.1. Lower legform impactor:

The lower legform impactor shall consist of two foam covered rigid segments, representing femur (upper leg) and tibia (lower leg), joined by a deformable, simulated knee joint. The overall length of the impactor shall be $926 \pm [5]$ mm, having a required test mass of $13.4 \pm [0.2]$ kg (see Figure 14).

Brackets, pulleys, etc. attached to the impactor for the purpose of launching it, may extend the dimensions shown in Figure 14.

- 6.3.1.1.1. The diameter of the femur and tibia shall be 70 ± 1 mm and both shall be covered by foam 'flesh' and skin. The foam flesh shall be 25 mm thick Confor™ foam type CF-45 or equivalent. The skin shall be made of neoprene foam, faced with 0.5 mm thick nylon cloth both sides, with an overall thickness of 6 mm.
- 6.3.1.1.2. The 'centre of the knee' is defined as the point about which the knee effectively bends.
- 6.3.1.1.3. The knee joint shall be fitted with deformable knee elements from the same batch as those used in the certification tests.
- 6.3.1.1.4. The "femur" is defined as all components or parts of components (including flesh, skin covering, damper, instrumentation and brackets, pulleys, etc. attached to the impactor for the purpose of launching it) above the level of the centre of the knee.
- 6.3.1.1.5. The "tibia" is defined as all components or parts of components (including flesh, skin covering, instrumentation and brackets, pulleys, etc. attached to the impactor for the purpose of launching it) below the level of the centre of the knee. Note that the tibia as defined includes allowances for the mass, etc., of the foot.
- 6.3.1.1.6. The total mass of the femur and tibia shall be $8.6 \pm \{0.1\}$ kg and $4.8 \pm \{0.1\}$ kg respectively, and the total mass of the impactor shall be $13.4 \pm \{0.2\}$ kg. The centre of gravity of the femur and tibia shall be $217 \pm \{10\}$ mm and $233 \pm \{10\}$ mm from the centre of the knee respectively. The moment of inertia of the femur and tibia, about a horizontal axis through the respective centre of gravity and perpendicular to the direction of impact, shall be $0.127 \pm \{0.010\}$ -kgm² and $0.120 \pm \{0.010\}$ kgm² respectively.
- 6.3.1.1.7. The impactor shall be fitted with foam flesh cut from one of up to four consecutive sheets of Confor™ foam flesh material or equivalent, produced from the same batch of manufacture (cut from one block or 'bun' of foam), provided that foam from one of these sheets was used in the dynamic certification test and the individual weights of these sheets are within ± 2 per cent of the weight of the sheet used in the certification test.
- 6.3.1.1.8. Lower legform instrumentation
- 6.3.1.1.8.1. A uniaxial accelerometer shall be mounted on the non-impacted side of the tibia, 66 ± 5 mm below the knee joint centre, with its sensitive axis in the direction of impact.
- 6.3.1.1.8.2. The impactor shall be instrumented to measure the bending angle and the shearing displacement between femur and tibia.
- 6.3.1.1.8.3. A damper shall be fitted to the shear displacement system and may be mounted at any point on the rear face of the impactor or internally. The damper properties shall be such that the impactor meets both the static and dynamic shear displacement requirements

and prevents excessive vibrations of the shear displacement system.

6.3.1.1.8.4. Transducers shall be fitted to measure knee bending angle and knee shearing displacement.

6.3.1.1.8.5. The instrumentation response value CFC, as defined in ISO 6487:2002, shall be 180 for all transducers. The CAC response values, as defined in ISO 6487:2002, shall be 50° for the knee bending angle, 10 mm for the shearing displacement and 500 g for the acceleration. This does not require that the impactor itself be able to physically bend and shear to these angles and displacements.

6.3.1.1.9. Lower legform certification

6.3.1.1.9.1. The lower legform impactor shall meet the performance requirements specified in ~~paragraph~~**section** 8.

6.3.1.1.9.2. The certified impactor may be used for a maximum of 20 impacts before re-certification. With each test new plastically deformable knee elements should be used. The impactor shall also be re-certified if more than one year has elapsed since the previous certification ~~or~~, if any impactor transducer output, in any impact, has exceeded the specified CAC **or has reached the mechanical limits of the leg impactor deformation capability**.

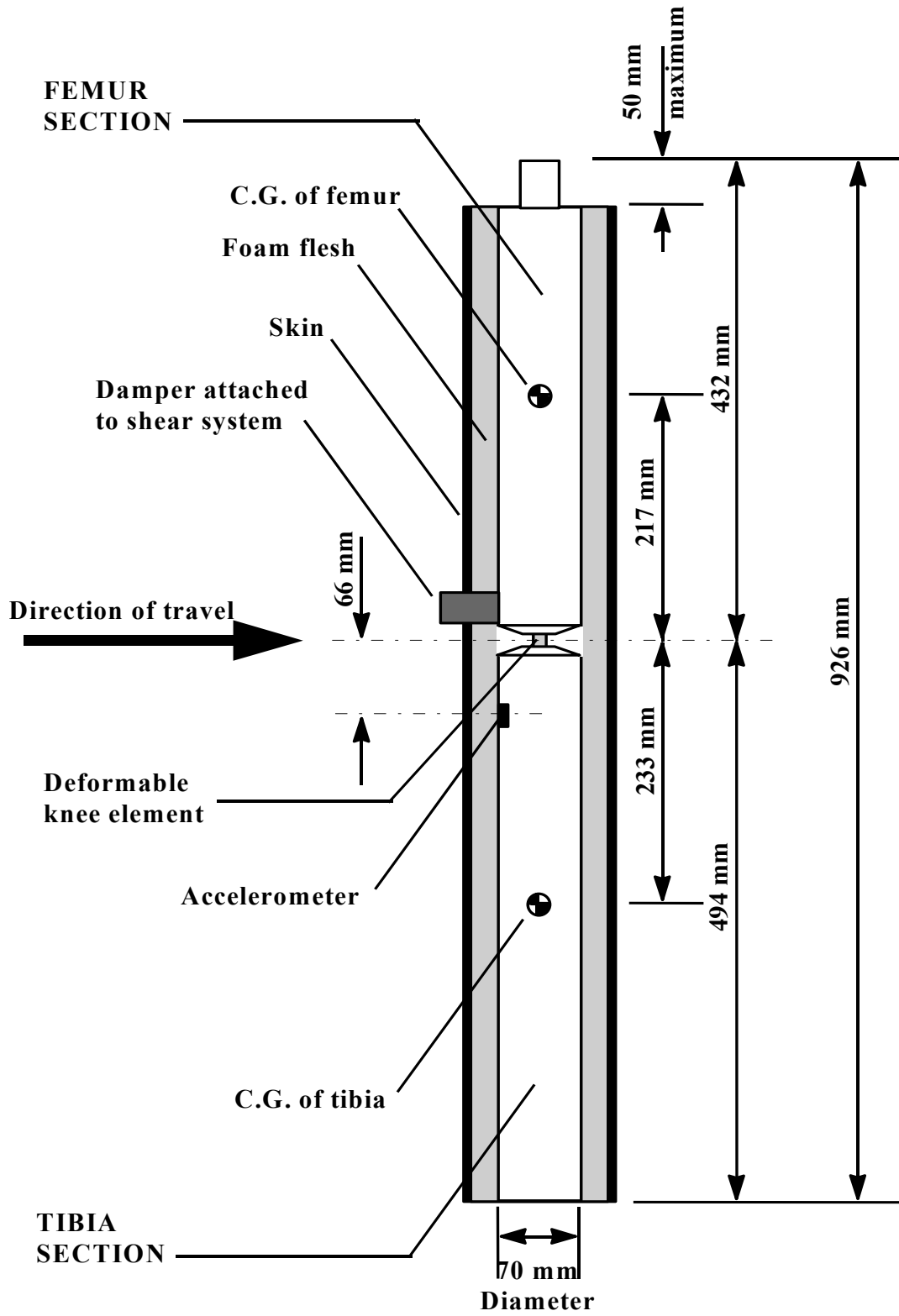

Figure 14: Lower legform impactor. (see §paragraph 6.3.1.1.)

6.3.1.2. Upper legform impactor:

The upper legform impactor shall be rigid, foam covered at the impact side, and 350 ± 5 mm long (see Figure 15).

6.3.1.2.1. The total mass of the upper legform impactor including those propulsion and guidance components which are effectively part of the impactor during the impact shall be $9.5 \text{ kg} \pm 0.1 \text{ kg}$. ~~The upper legform impactor mass may be adjusted from this value by up to $\pm 1 \text{ kg}$, provided the required impact velocity is also changed using the formula:~~

~~$$V = \sqrt{(1.170/M)} \sqrt{1.170/M}$$~~

~~Where:~~

~~V = impact velocity (m/s)~~

~~M = mass (kg), measured to an accuracy of better than ± 1 per cent]~~

The above highlighted section should be removed as the mass will not change for this test.

6.3.1.2.2. The total mass of the front member and other components in front of the load transducer assemblies, together with those parts of the load transducer assemblies in front of the active elements, but excluding the foam and skin, shall be $1.95 \pm 0.05 \text{ kg}$.

6.3.1.2.3. The torque limiting joint shall be set so that the longitudinal axis of the front member is perpendicular to the axis of the guidance system, with a tolerance of $\pm 2^\circ$, with the joint friction torque set to ~~a minimum of 650-675 Nm~~ $\pm 25 \text{ Nm}$.

6.3.1.2.4. The centre of gravity of those parts of the impactor which are effectively forward of the torque limiting joint, including any weights fitted, shall lie on the longitudinal centre line of the impactor, with a tolerance of $\pm 10 \text{ mm}$.

6.3.1.2.5. The length between the load transducer centre lines shall be $310 \pm 1 \text{ mm}$ and the front member diameter shall be $50 \pm 1 \text{ mm}$.

6.3.1.2.6. The foam flesh shall be two sheets of 25 mm thick ConforTM foam type CF-45 or equivalent. The skin shall be a 1.5 mm thick fibre reinforced rubber sheet. The foam and rubber skin together shall weigh $0.6 \pm 0.1 \text{ kg}$ (this excludes any reinforcement, mountings, etc. which are used to attach the rear edges of the rubber skin to the rear member). The foam and rubber skin shall be folded back towards the rear, with the rubber skin attached via spacers to the rear member so that the sides of the rubber skin are held parallel. The foam shall be of such a size and shape that an adequate gap is maintained between the foam and components behind the front member, to avoid significant load paths between the foam and these components.

6.3.1.2.7. Upper legform instrumentation

6.3.1.2.7.1. The front member shall be strain gauged to measure bending moments in three positions, as shown in Figure 15, each using a separate channel. The strain gauges are located on the impactor on the back of the front member. The two outer strain gauges are located 50 ± 1 mm from the impactor's symmetrical axis. The middle strain gauge is located on the symmetrical axis with a ± 1 mm tolerance.

6.3.1.2.7.2. Two load transducers shall be fitted to measure individually the forces applied at either end of the upper legform impactor, plus strain gauges measuring bending moments at the centre of the upper legform impactor and at positions 50 mm either side of the centre line, (see Figure 15).

6.3.1.2.7.3. The instrumentation response value CFC, as defined in ISO 6487:2002, shall be 180 for all transducers. The CAC response values, as defined in ISO 6487:2002, shall be 10 kN for the force transducers and ~~1~~1,000 Nm for the bending moment measurements.

6.3.1.2.8. Upper legform certification

6.3.1.2.8.1. The upper legform impactor shall meet the performance requirements specified in ~~paragraph~~section 8.

6.3.1.2.8.2. The certified impactor may be used for a maximum of 20 impacts before re-certification (this limit does not apply to propulsion or guidance components). The impactor shall also be re-certified if more than one year has elapsed since the previous certification or if any impactor transducer output, in any impact, has exceeded the specified CAC.

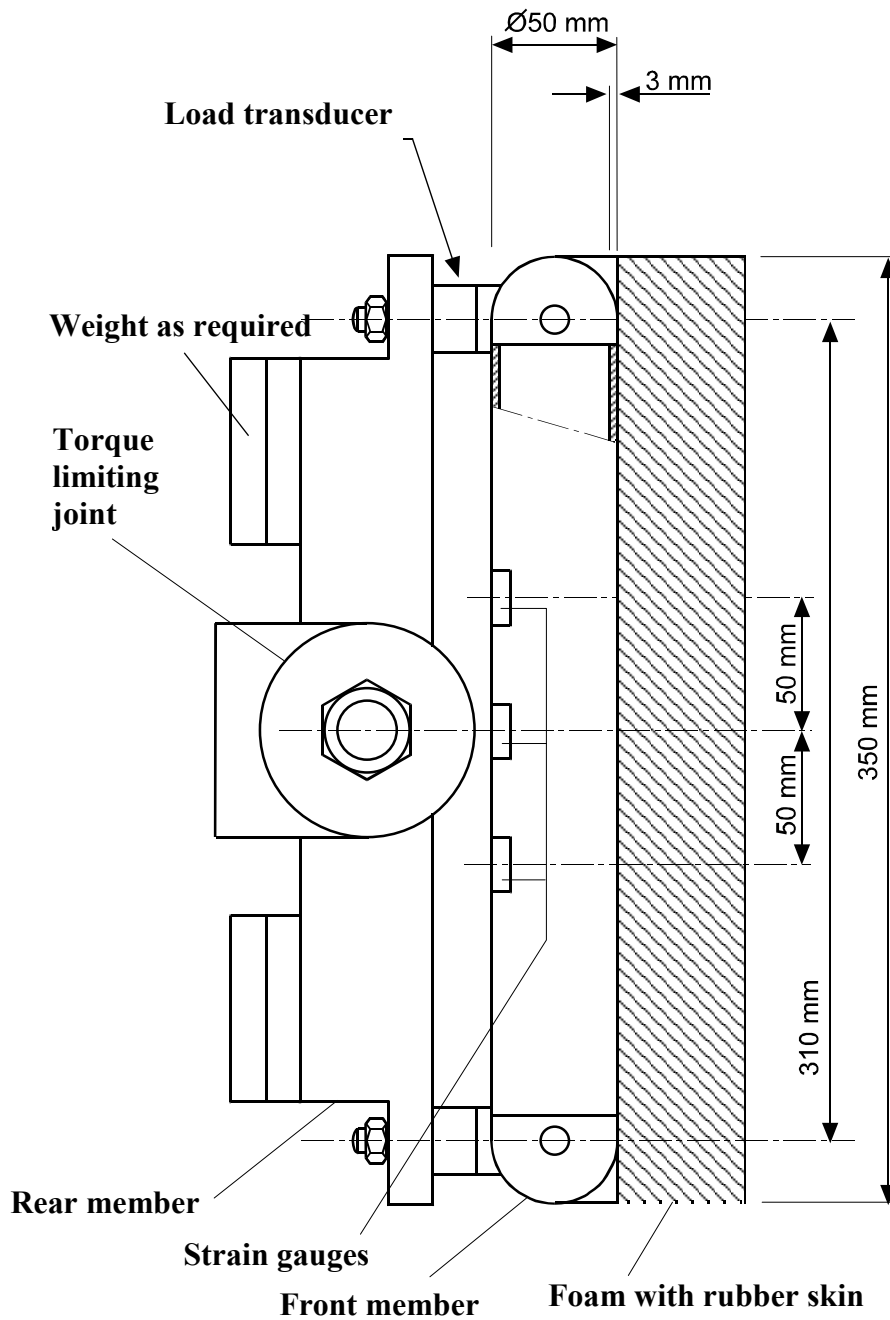

Figure 15: Upper legform impactor (see §paragraph 6.3.1.2.)

6.3.2. Child and ~~Adult~~-adult headform impactors

6.3.2.1. Child headform impactor (see Figure 16)

The child headform impactor shall be made of aluminium, be of homogenous construction and be of spherical shape. The overall diameter shall be 165 ± 1 mm. The mass shall be 3.5 ± 0.07 kg. The moment of inertia about an axis through the centre of gravity and perpendicular to the direction of impact shall be within the range of [0.0080

to 0.01200.0075 to 0.0200-] kgm². The centre of gravity of the headform impactor including instrumentation shall be located in the geometric centre of the sphere with a tolerance of \pm [52] mm.

The sphere shall be covered with a 14 ± 0.5 mm thick synthetic skin, which shall cover at least half of the sphere.

6.3.2.1.1. Child headform instrumentation

A recess in the sphere shall allow for mounting one triaxial or three uniaxial accelerometers within \pm 10 [30] mm seismic mass location tolerance from the centre of the sphere for the measurement axis, and \pm 1 mm seismic mass location tolerance from the centre of the sphere for the perpendicular direction to the measurement axis.

If three uniaxial accelerometers are used, one of the accelerometers shall have its sensitive axis perpendicular to the mounting face A (see figure 16) and its seismic mass shall be positioned within a cylindrical tolerance field of 1 mm radius and [20] mm length. The centre line of the tolerance field shall run perpendicular to the mounting face and its mid-point shall coincide with the centre of the sphere of the headform impactor.

The remaining accelerometers shall have their sensitive axes perpendicular to each other and parallel to the mounting face A and their seismic mass shall be positioned within a spherical tolerance field of 10 mm radius. The centre of the tolerance field shall coincide with the centre of the sphere of the headform impactor.

The instrumentation response value CFC, as defined in ISO 6487: 2002, shall be 1,000. The CAC response value, as defined in ISO 6487: 2002, shall be 500 g for the acceleration.

6.3.2.1.3-2. First natural frequency

The first natural frequency of the headform impactor shall be over 5,000 Hz.

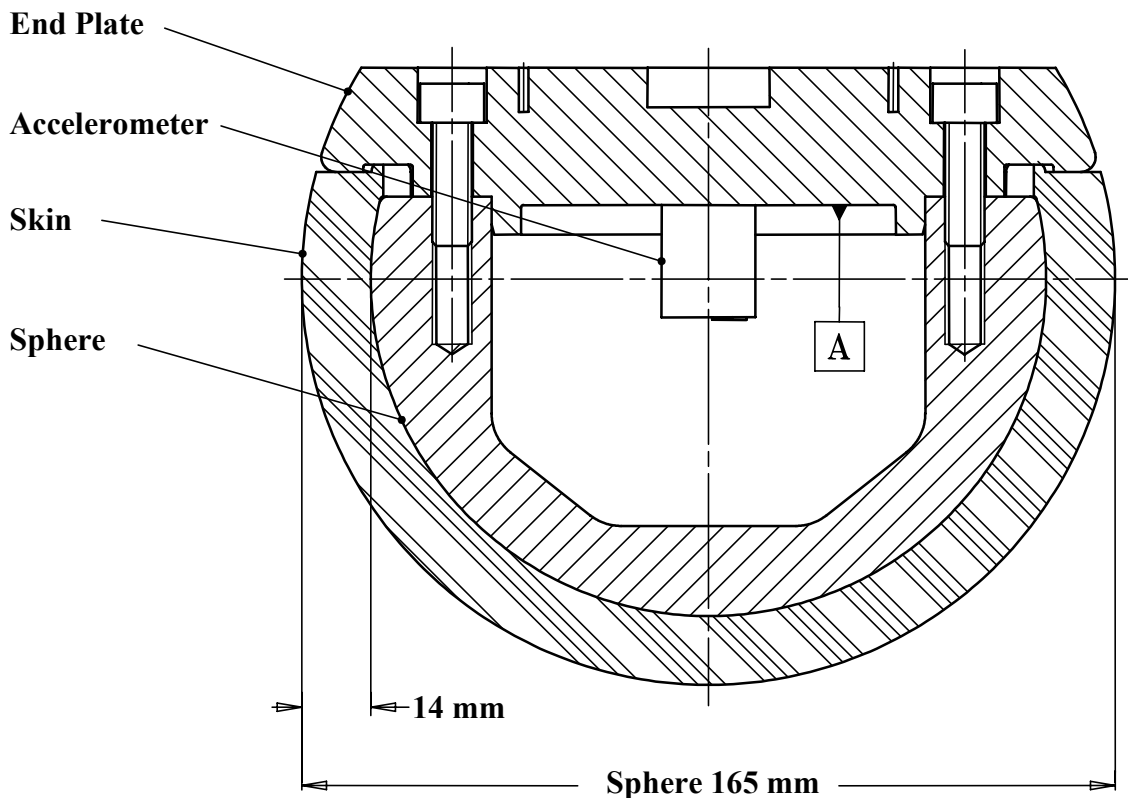

Figure 16: Child headform impactor (see §paragraph 6.3.2.1.)

~~6.3.2.1.4 — The child headform test procedures are detailed in paragraph 7.2 below. — Remove~~

6.3.2.2. Adult headform impactor (see Figure 17)

The adult headform impactor shall be made of aluminium, be of homogenous construction and be of spherical shape. The overall diameter is 165 ± 1 mm as shown in Figure 17. The mass shall be $[4.5 \pm 0.1]$ kg. The moment of inertia about an axis through the centre of gravity and perpendicular to the direction of impact shall be with in the rage of $[0.0075$ to $0.0200]$ kgm^2 . The centre of gravity of the headform impactor including instrumentation shall be located in the geometric centre of the sphere with a tolerance of $\pm [5]$ mm.

The sphere shall be covered with a 14 ± 0.5 mm thick synthetic skin, which shall cover at least half of the sphere.

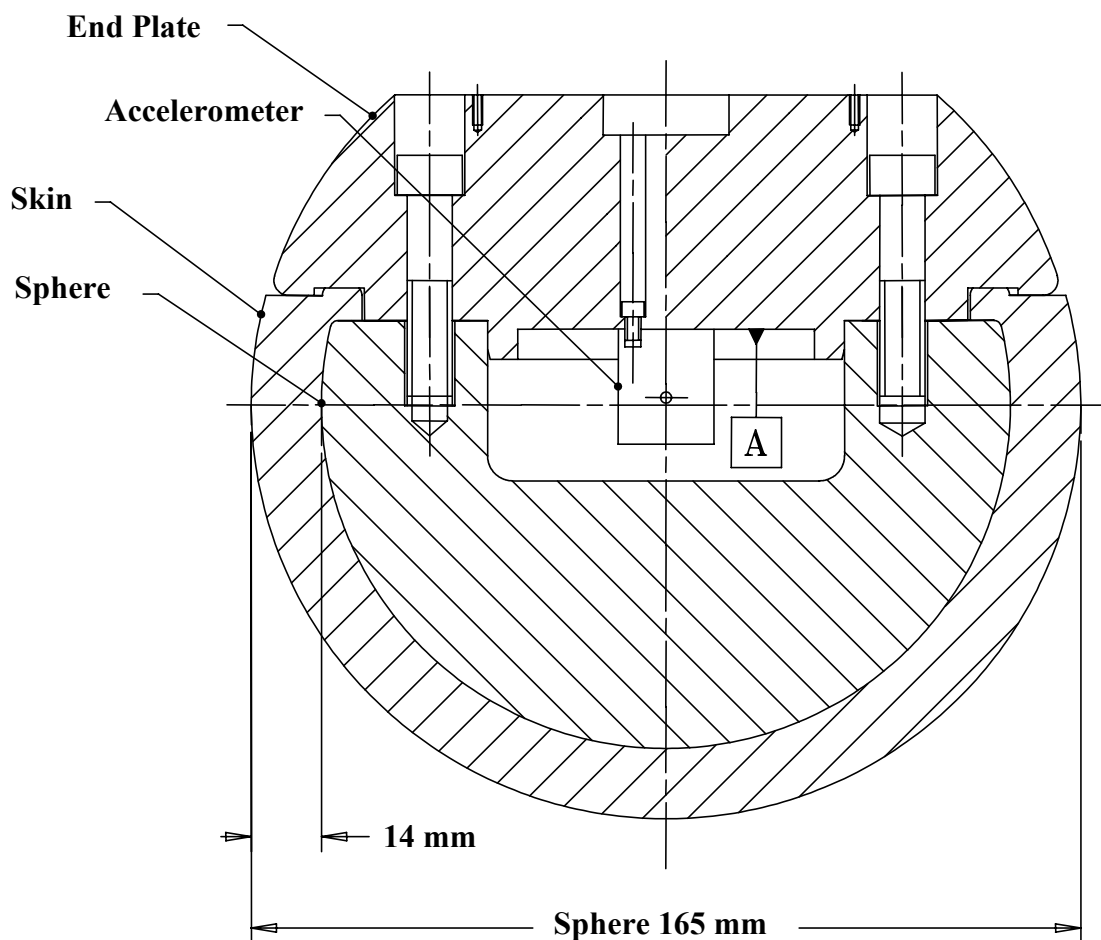

Figure 17: Adult headform impactor (see §paragraph 6.3.2.2)

6.3.2.2.1. Adult headform instrumentation

A recess in the sphere shall allow for mounting one triaxial or three uniaxial accelerometers within \pm {3010} mm seismic mass location tolerance from the centre of the sphere for the measurement axis, and \pm {1} mm seismic mass location tolerance from the centre of the sphere for the perpendicular direction to the measurement axis.

If three uniaxial accelerometers are used, one of the accelerometers shall have its sensitive axis perpendicular to the mounting face A (see figure 17) and its seismic mass shall be positioned within a cylindrical tolerance field of 1 mm radius and 20 mm length. The centre line of the tolerance field shall run perpendicular to the mounting face and its mid-point shall coincide with the centre of the sphere of the headform impactor.

The remaining accelerometers shall have their sensitive axes perpendicular to each other and parallel to the mounting face A and their seismic mass shall be positioned within a spherical tolerance field of 10 mm radius. The centre of the tolerance field shall coincide with the centre of the sphere of the headform impactor.

The instrumentation response value CFC, as defined in ISO 6487: 2002, shall be 1,000. The CAC response value, as defined in ISO 6487: 2002, shall be 500 g for the acceleration.

6.3.2.2.2. First natural frequency

First natural frequency of the headform impactors shall be over 5,000 Hz.

6.3.2.3. Rear face of the headform impactors

A rear flat face shall be provided on the outer surface of the headform impactors which is perpendicular to the direction of travel, and typically perpendicular to the axis of one of the accelerometers as well as being a flat plate capable of providing for access to the accelerometers and an attachment point for the propulsion system.

6.3.2.4. Certification of the headform impactors

The headform impactors shall meet the performance requirements specified in ~~paragraph~~[section 8](#). The certified impactors may be used for a maximum of 20 impacts before re-certification. The impactors shall be re-certified if more than one year has elapsed since the previous certification or if the transducer output, in any impact, has exceeded the specified CAC.

7. TEST PROCEDURES

-

[\[Refer to Annex 2 for impactor handling procedures\]](#)

7.1. Legform to Bumper Test Procedures

~~Refer to Annex 2 for impactor handling procedures~~

7.1.1. Lower legform to bumper test procedure:

7.1.1.1. ~~A minimum of three lower legform to bumper tests shall be carried out, one each to the middle and the outer thirds of the bumper at positions judged to be the most likely to cause injury. Tests shall be to different types of structure, where they vary throughout the area to be assessed. The selected test-target points shall be in the bumper test area as defined in paragraph 3.2210 [and shall be a minimum of 132 mm apart, and a minimum of 66 mm inside the defined corners of the bumper. These minimum distances are is to be set with a flexible tape held tautly along the outer surface of the vehicle]. The positions tested by the laboratories shall be indicated in the test report.~~

~~7.1.1.1.1. — Manufacturers might apply for derogation concerning an exemption zone for a removable towing hook.~~

7.1.1.2. The direction of the impact velocity vector shall be in the horizontal plane and parallel to the longitudinal vertical plane of the vehicle. The tolerance for the direction of the velocity vector in the horizontal plane and in the longitudinal plane shall be $\pm 2^\circ$ at the time of first contact. The axis of the impactor shall be perpendicular to the horizontal plane with a tolerance of $\pm 2^\circ$ in the lateral and longitudinal plane. The horizontal, longitudinal and lateral planes are orthogonal to each other (see Figure 18).

7.1.1.3. The bottom of the impactor shall be at 25 mm above ground reference level at the time of first contact with the bumper (see Figure 19), with a ± 10 mm tolerance. When setting the height of the propulsion system, an allowance must be made for the influence of gravity during the period of free flight of the impactor.

7.1.1.3.1. The lower legform impactor for the bumper tests shall be in 'free flight' at the moment of impact. The impactor shall be released to free flight at such a distance from the vehicle that the test results are not influenced by contact of the impactor with the propulsion system during rebound of the impactor.

The impactor may be propelled by an air, spring or hydraulic gun, or by other means that can be shown to give the same result.

7.1.1.3.2. At the time of first contact the impactor shall have the intended orientation about its vertical axis, for the correct operation of its knee joint, with a tolerance of $\pm 5^\circ$ (see Figure 18).

7.1.1.3.3. At the time of first contact the centre line of the impactor shall be within a ± 10 mm tolerance to the selected impact location.

7.1.1.3.4. During contact between the impactor and the vehicle, the impactor shall not contact the ground or any object which is not part of the vehicle.

7.1.1.4. The impact velocity of the impactor when striking the bumper shall be 11.1 ± 0.2 m/s. The effect of gravity shall be taken into account when the impact velocity is obtained from measurements taken before the time of first contact.

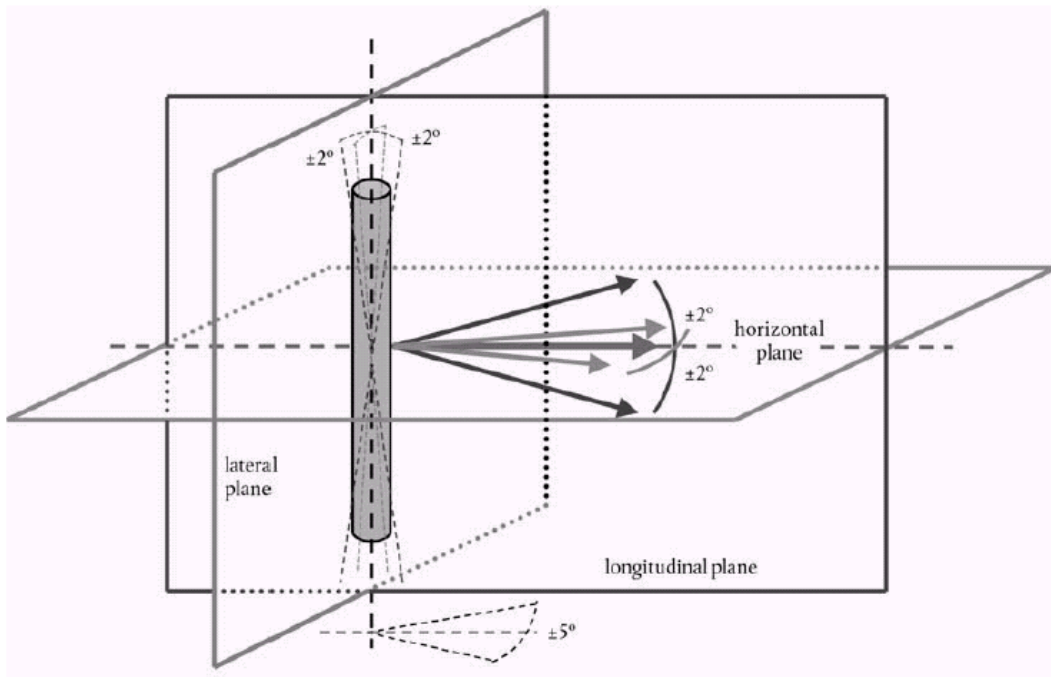

Figure 18: Tolerances of angles for the lower legform impactor at the time of first impact (see §paragraphs 7.1.1.2 and 7.1.1.3.2.)

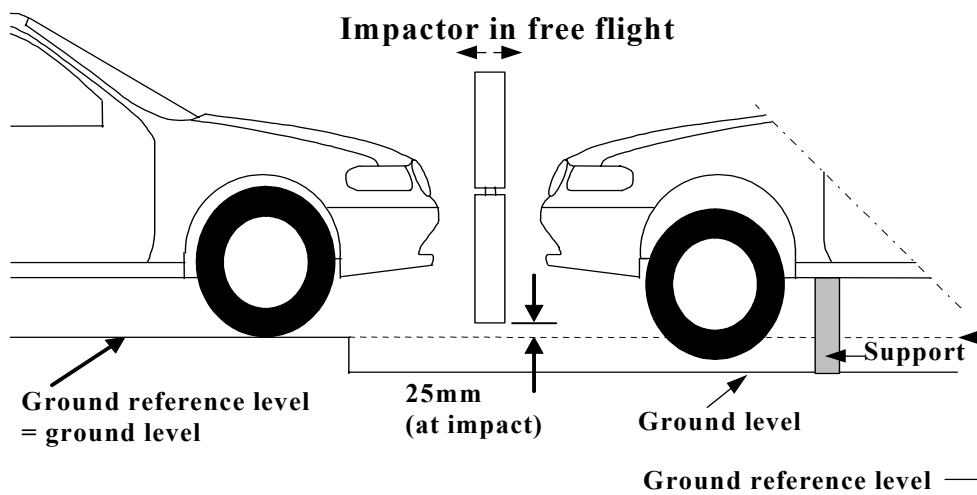

Figure 19: Lower legform to bumper tests for complete vehicle in normal ride attitude (left) and for cut-body mounted on supports (right) (see §paragraph 7.1.1.3)

7.1.2. Upper legform to bumper test procedure:

7.1.2.1. [If the lower bumper height at the test position is more than 500 mm and the manufacturer elects to perform an upper legform test instead of a lower legform test], ~~a minimum of three lower upper legform to bumper tests shall be carried out, one each to the middle and the outer thirds of the bumper at positions judged to be the most likely to cause injury. Tests~~ the selected target points shall be in the bumper test area as defined in paragraph 3.2210 [and shall be a minimum of 132 mm apart. The minimum distance is to be set with a flexible tape held tautly along the outer surface of the vehicle]. The positions tested shall be indicated in the test report.

~~tests shall be to different types of structure, where they vary throughout the area to be assessed. The selected test points shall be a minimum of 132 mm apart, and a minimum of 66 mm inside the defined corners of the bumper. These minimum distances are to be set with a flexible tape held tautly along the outer surface of the vehicle. The positions tested by the laboratories shall be indicated in the test report.~~

~~7.1.2.1.1. — Manufacturers might apply for derogation concerning an exemption zone for a removable towing hook.~~

7.1.2.2. The direction of impact shall be parallel to the longitudinal axis of the vehicle, with the axis of the upper legform vertical at the time of first contact. The tolerance to this direction is $\pm [2]^\circ$.

~~7.1.2.2.1. —~~ At the time of first contact the impactor centre line shall be midway between the upper bumper reference line and the lower bumper reference line with a ± 10 mm tolerance and laterally with the selected impact location with a tolerance of ± 10 mm.

7.1.2.3. The impact velocity of the upper legform impactor when striking the bumper shall be $11.1 \pm [0.2]$ m/s.

7.2. Headform Test Procedures

7.2.1. Propulsion of the headform impactors

The headform impactors shall be in "free flight" at the moment of impact, at the required impact velocity (see paragraphs 7.3.5. and 7.4.5.) and the required direction of impact (see ~~paragraphs~~**sections** 7.3.6. and 7.4.6.).

The impactors shall be released to free flight at such a distance from the vehicle that the test results are not influenced by contact of the impactor with the propulsion system during rebound of the impactor.

7.2.2. Measurement of impact velocity

The velocity of the headform impactor shall be measured at some point during the free flight before impact, in accordance with the method specified in ISO 3784:1976 (ISO number to be checked). The accuracy of velocity measurement shall be ± 0.01 m/sec. The measured velocity shall be adjusted considering all factors which may affect the

impactor between the point of measurement and the point of impact, in order to give the velocity of the impactor at the time of impact. The angle of the velocity vector at the time of impact shall be calculated or measured.

7.2.3. Recording

The acceleration time histories shall be recorded, and HIC shall be calculated. The first point of contact on the front structure of the vehicle shall be recorded. Recording of test results shall be in accordance with ISO 6487:2002.

[7.2.4 “Bonnet Top Zone A” and “Bonnet Top Zone B”

7.2.4.1 The manufacturer shall identify the zones of the bonnet top where the Head Performance Criterion (HPC) must not exceed 1000 (Bonnet Top Zone A) respectively [1700] (Bonnet Top Zone B), according to the technical requirements set out in paragraph 5.2 (see Figure 20).

Figure 20

Bonnet Top Zone A and Bonnet Top Zone B

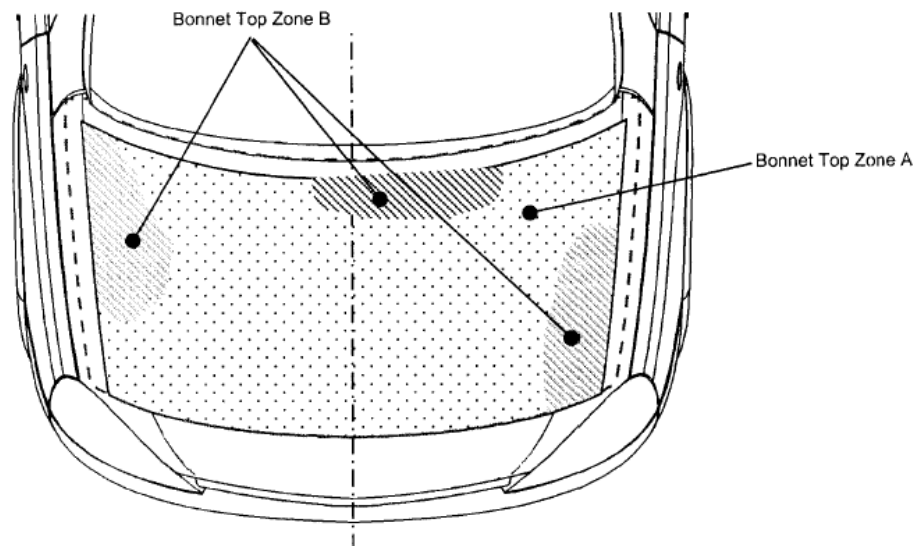

Figure 20: Bonnet Top Zone A and Bonnet Top Zone B

7.2.4.2 Marking of the “Bonnet Top” impact area as well as “Bonnet Top Zone A” and “Bonnet Top Zone B” will be based on a drawing supplied by the manufacturer, when viewed from a horizontal plane above the vehicle that is parallel to the vehicle horizontal zero plane. A sufficient number of x and y co-ordinates shall be supplied by the manufacturer to mark up the areas on the actual vehicle while considering the vehicle outer contour in the z direction.

7.2.4.3 The areas of “Bonnet Top Zone A” and “Bonnet Top Zone B” may consist of several parts, with the number of these parts not being limited.

7.2.4.4 The calculation of the surface of the impact area as well as the surface areas of “Bonnet Top Zone A” and “Bonnet Top Zone B” shall be done on the basis of a projected bonnet when viewed from a horizontal plane parallel to the horizontal zero plane above the vehicle, on the basis of the drawing data supplied by the manufacturer.]

~~7.2.5 [specify min time in between tests]~~

7.3. Child headform Test test Procedureprocedure:

This test procedure is applicable with respect to the requirements of paragraph 5.2.1. and 5.2.3. of this **Regulation**gr.

7.3.1. Tests shall be made to the front structure within the boundaries as defined in paragraph 3.11. For tests on the rear area of the bonnet top, the headform impactor shall not contact the windscreen or A-pillar before impacting the bonnet top.

~~7.3.2. [A minimum of [eighteen 9] tests shall be carried out with the child headform impactor, [six 3] tests each to the middle and the outer thirds of the bonnet top, as described in paragraph 3.25. at positions judged to be the most likely to cause injury. Tests shall be to different types of structure, where these vary throughout the area to be assessed.]~~

7.3.3. ~~The No test impact points~~ shall be located so that the impactor ~~is will not expected to~~ impact the test area with a glancing blow resulting in a more severe second impact. ~~The S~~selected ~~test impact~~ pointss on the bonnet for the child headform impactor shall, at the time of first contact:

~~-be a minimum of 165 mm apart,~~

~~-----~~ be a minimum of 82.5 mm inside the defined bonnet side reference lines, as defined in paragraph 3.2322.

~~-----~~ be forward of the WAD1700 line as defined in paragraph 3.3129, or a minimum of 82.5 mm forwards of the bonnet rear reference line, as defined in paragraph 3.223.76, whichever is most forward.-

~~----- [specify min time in between tests]~~

~~-----~~ Each selected test point for the child headform shall also be a minimum of 165 mm rearwards of the bonnet leading edge reference line, as defined in paragraph 3.65.

If the WAD1700 line is located, at any point, in the windscreen test area, as defined in paragraph 3.3634., at any point. , [2] impact points selected test points on the windscreen test area for the child headform impactor shall, at time of first contact:

~~-be a minimum of 165 mm apart,~~

- be forward of the WAD1700 line or a minimum of 82.5 mm forwards of the windscreen rear reference line, as defined in paragraph 3.3533., ~~or forwards of the WAD1700 line what ever whichever~~ is most forward.

If the WAD1700 line is located, at any point, rearward of the windscreen rear reference line as defined in paragraph 3.33, impact points selected on the windscreen area for the child head form impactor shall, at time of first contact:

- be a minimum of 82.5 mm forward of the windscreen rear reference line

7.3.3.1. These minimum distances are to be set with a flexible tape held tautly along the outer surface of the vehicle. ~~If, however, the vehicle configuration does not allow the number of eighteen impact points to be reached while maintaining the minimum spacing between impact points, then less than eighteen tests may be performed.~~

7.3.3.2. The points selected for testing shall be indicated in the test report.

7.3.4. The point of first contact of the headform impactor shall be [within a ± 10 mm tolerance to the selected impact ~~location~~point.]

7.3.5. The headform velocity at the time of impact shall be [~~8.9~~9.7 ± 0.2 m/s. (32km/h)] [~~which simulates the vehicle impact speed of 40 km/h, the shape category of the vehicle under test and the location of each selected test point.~~]

~~The effect of gravity shall be taken into account when the impact velocity is obtained from measurements taken before the time of first contact.~~

7.3.6. The direction of impact shall be as specified as follows:

~~7.3.6.1.~~ The direction of impact shall be in the longitudinal vertical plane of the vehicle to be tested at an angle of 50° to the horizontal. [The situation of windscreen is to be confirmed prior to the next meeting]. The tolerance for this direction is $\pm 2^\circ$. The direction of impact of tests to the front structure shall be downward and rearward.

~~The following two sections will depend on the agreement of approach to the use of variable angles.~~

~~[7.3.6.2. For vehicles where the bonnet angle, as defined in paragraph 3.3, is not lower than 30° , the angle of impact on the bonnet shall be~~

~~$25^\circ \pm [2]^\circ$ for tests point on the bonnet top, as defined in paragraph 3.8 or $25^\circ \pm [2]^\circ$ for test point in the windscreen test area, as defined in paragraph 3.36~~

~~to the Ground Reference Level.~~

~~7.3.6.3. For vehicles where the bonnet angle, as defined in paragraph 3.3., is lower than 30° :~~

~~7.3.6.3.1. If the bonnet leading edge height (BLEH), as defined in paragraph 3.5., is not lower than 835 mm, the angle of impact on the bonnet shall be~~

~~60° ± [2]° for tests point on the bonnet top, as defined in paragraph 3.8.~~

~~or~~

~~40° ± [2]° for test point in the windscreen test area, as defined in paragraph 3.36.~~

~~to the Ground Reference Level.~~

~~7.3.6.3.2. If the bonnet leading edge height (BLEH), as defined in paragraph 3.5., is lower than 835 mm, the angle of impact on the bonnet shall be~~

~~65° ± [2]° for tests point on the bonnet top, as defined in paragraph 3.8.~~

~~or~~

~~40° ± [2]° for test point in the windscreen test area, as defined in paragraph 3.36.~~

~~to the Ground Reference Level.]~~

~~7.3.6.4. [The effect of gravity shall be taken into account when the impact angle is obtained from measurements taken before the time of first contact.]~~

7.4. Adult headform test procedure:

This test procedure is applicable with respect to the requirements of paragraph 5.2.2. and 5.2.3. of the performance requirements of this Regulation.

7.4.1. Tests shall be made to the front structure within the boundaries as defined in paragraph 3.1. For tests at the rear of the bonnet top, the headform impactor shall not contact the windscreen or A-pillar before impacting the bonnet top.

~~7.4.2. [A minimum of [eighteen 9nine] tests shall be carried out with the adult headform impactor, [six 3three] tests each to the middle and the outer thirds of the test area, as described in paragraph 3.25., at positions judged to be the most likely to cause injury. Tests shall be to different types of structure, where these vary throughout the area to be assessed.]~~

7.4.3. No impact point shall be located so that the impactor will impact the test area with a glancing blow resulting in a more severe second impact.
Selected impact points on the bonnet for the adult headform impactor shall, at the time of first contact:

~~The Any test points shall be located so that the impactor is will not expected to impact the test area with a glancing blow resulting in a more severe second impact. The Any The selected test points on the bonnet for the adult headform impactor shall, at the time of first contact:~~

~~_____ be a minimum of 165 mm apart,~~

- be a minimum of 82.5 mm inside the defined bonnet side reference lines, as defined in paragraph 3.2322.;

- be forward of the WAD2100 line or a minimum of 82.5 mm forwards of the bonnet rear reference line, as defined in paragraph 3.76, or forwards of the WAD2100 line what., whichever is most forward.

~~[specify min time in between tests]~~

If the rear reference line for adult headform, as defined in paragraph 3.21, is located, at any point, in the windscreen test area as defined in paragraph 3.36, 34 impact points selected on the windscreen test area for the adult headform impactor shall, at time of first contact: ~~partly on or forward the rear windscreen reference line, as defined in paragraph 3.23, [two] selected tests points in the windscreen test area, as defined in paragraph 3.36, for the adult headform impactor shall, at the time of first contact:~~

~~- be a minimum of 165 mm apart,~~

- be forward of the rear reference line for adult headform or a minimum of 82.5 mm forward of the windscreen rear reference line for adult headform, as defined in paragraph 3.21, 33, 33., whichever is most forward;
- be rearward of the WAD1700 line or a minimum of 82.5 mm rearwards of the windscreen lower reference line, as defined in paragraph 3.31, (see paragraph 3.33.) or rearwards of the WAD1700 line what whichever is most rearward.

~~Each selected test point for the adult headform shall also be a minimum of 165 mm rearwards of the bonnet leading edge reference line, as defined in paragraph 3.6.~~

If the rear reference line for adult head form as defined in paragraph 3.21 is located, at any point, rearward of the windscreen rear reference line as defined in paragraph 3.33, impact points selected on the windscreen area for the adult head form impactor shall, at time of first contact:

- be a minimum of 82.5 mm forward of the windscreen rear reference line
- be rearward of the WAD1700 line or a minimum of 82.5 mm rearwards of the windscreen lower reference line, as defined in paragraph 3.31, whichever is most rearward.

7.4.3.1. These minimum distances are to be set with a flexible tape held tautly along the outer surface of the vehicle. ~~If, however, the vehicle configuration does not allow the number of eighteen impact points to be reached while maintaining the minimum spacing between impact points, then less than eighteen tests may be performed.~~

7.4.3.2. The points selected for testing shall be indicated in the test report.

7.4.4. The point of first contact of the headform impactor shall be within a ± 10 mm tolerance to the selected impact location point.

7.4.5. The headform velocity at the time of impact shall be ~~[8.9-9.7 ± 0.2 m/s. (32km/h)] [which simulates the vehicle impact speed of 40 km/h, the shape category of the vehicle under test and the location of each selected test point.].~~

~~The effect of gravity shall be taken into account when the impact velocity is obtained from measurements taken before the time of first contact~~

7.4.6. The direction of impact shall be as specified as follows:

~~7.4.6.1. —~~ The direction of impact shall be in the fore and aft vertical plane of the paragraph of the vehicle to be tested ~~at an angle of 65° to the horizontal [The situation of windscreen is to be confirmed prior to the next meeting].~~ The tolerance for this direction is $\pm 2^\circ$. The direction of impact of tests to the front structure shall be downward and rearward.

~~The following two sections will depend on the agreement of approach to the use of variable angles.~~

~~[7.4.6.2. — For vehicles where the bonnet angle, as defined in paragraph 3.3., is not lower than 30°, the angle of impact in all cases shall be~~

~~50° \pm [2]° for tests point on the bonnet top, as defined in paragraph 3.8.~~

~~or~~

~~50° \pm [2]° for test point in the windscreen test area, as defined in paragraph 3.36.~~

~~— to the Ground Reference Level.~~

~~7.4.6.3. — For vehicles where the bonnet angle, as defined in paragraph 3.3., is lower than 30°:~~

~~7.4.6.3.1. — If the bonnet leading edge height (BLEH), as defined in paragraph 3.5., is not lower than 835 mm, the angle of impact on the bonnet shall be 90° \pm [2]°~~

~~90° \pm [2]° for tests point on the bonnet top, as defined in paragraph 3.8.~~

~~or~~

~~40° \pm [2]° for test point in the windscreen test area, as defined in paragraph 3.36.~~

~~— to the Ground Reference Level.~~

~~7.4.6.3.2. — If the bonnet leading edge height (BLEH), as defined in paragraph 3.5., is lower than 835 mm, the angle of impact on the bonnet shall be~~

~~65° \pm [2]° for tests point on the bonnet top, as defined in paragraph 3.8.~~

~~or~~

~~40° \pm [2]° for test point in the windscreen test area, as defined in paragraph 3.36.~~

~~to the Ground Reference Level.]~~

~~7.4.6.4. — The effect of gravity shall be taken into account when the impact angle is obtained from measurements taken before the time of first contact.~~

8. — CERTIFICATION OF IMPACTORS.

The impactors that are used in the tests ~~detailed~~ described in this gtr are required to comply with appropriate performance requirements.

The requirements for the lower legform impactor are specified in ~~paragraph Section~~ 8.1., the upper legform impactor requirements are specified in ~~paragraph Section~~ 8.2. and the adult and child headform impactors requirements are specified in ~~paragraph Section~~ 8.3.

8.1. Lower ~~Legform-legform Impactor-impactor Certification~~certification

8.1.1. Static tests

8.1.1.1. The lower legform impactor shall meet the requirements specified in paragraph 8.1.1.2. when tested as specified in paragraph 8.1.1.4. and the impactor shall meet the requirements specified in paragraph 8.1.1.3. when tested as specified in paragraph 8.1.1.5.

For both tests the impactor shall have the intended orientation about its longitudinal axis, for the correct operation of its knee joint, with a tolerance of $\pm 2^\circ$.

The stabilized temperature of the impactor during certification shall be $20^\circ \pm 2^\circ\text{C}$.

The CAC response values, as defined in ISO 6487:~~2000,2002~~ shall be 50° for the knee bending angle and 500 N for the applied force when the impactor is loaded in bending in accordance with paragraph 8.1.1.4., and 10 mm for the shearing displacement and 10 kN for the applied force when the impactor is loaded in shearing in accordance with paragraph 8.1.1.5. For both tests low-pass filtering at an appropriate frequency is permitted, to remove higher frequency noise without significantly affecting the measurement of the response of the impactor.

8.1.1.2. When the impactor is loaded in bending in accordance with paragraph 8.1.1.4., the applied force/bending angle response shall be within the limits shown in Figure ~~2021~~. Also, the energy taken to generate 15.0° of bending shall be 100 ± 7 J.

8.1.1.3. When the impactor is loaded in shearing in accordance with paragraph 8.1.1.5., the applied force/shearing displacement response shall be within the limits shown in Figure ~~2122~~.

8.1.1.4. The impactor, without foam covering and skin, shall be mounted with the tibia firmly clamped to a fixed horizontal surface and a metal tube connected firmly to the femur, as shown in Figure ~~2223~~. To avoid friction errors, no support shall be provided to the femur section or the metal tube. The bending moment applied at the centre of the knee joint, due to the weight of the metal tube and other components (excluding the legform itself), shall not exceed 25 Nm.

A horizontal normal force shall be applied to the metal tube at a distance of 2.0 ± 0.01 m from the centre of the knee joint and the resulting angle of knee deflection shall be recorded. The load shall be increased until the angle of deflection of the knee is in excess of 22° .

The energy is calculated by integrating the force with respect to the bending angle in radians, and multiplying by the lever length of 2.0 ± 0.01 m.

- 8.1.1.5. The impactor, without foam covering and skin, shall be mounted with the tibia firmly clamped to a fixed horizontal surface and a metal tube connected firmly to the femur and restrained at 2.0 m from the centre of the knee joint, as shown in Figure ~~23~~24.

A horizontal normal force shall be applied to the femur at a distance of 50 mm from the centre of the knee joint and the resulting knee shearing displacement shall be recorded. The load shall be increased until the shearing displacement of the knee is in excess of 8.0 mm or the load is in excess of 6.0 kN.

8.1.2. Dynamic tests

- 8.1.2.1. The lower legform impactor shall meet the requirements specified in paragraph 8.1.2.2. when tested as specified in paragraph 8.1.2.4.

The stabilized temperature of the impactor during certification shall be $20^{\circ} \pm 2^{\circ}\text{-C}$.

- 8.1.2.2. When the impactor is impacted by a linearly guided certification impactor, as specified in paragraph 8.1.2.4., the maximum upper tibia acceleration shall be not less than 120 g and not more than 250 g. The maximum bending angle shall be not less than 6.2° and not more than 8.2° . The maximum shearing displacement shall be not less than 3.5 mm and not more than 6.0 mm.

For all these values, the readings used shall be from the initial impact with the certification impactor and not from the arresting phase. Any system used to arrest the impactor or certification impactor shall be so arranged that the arresting phase does not overlap in time with the initial impact. The arresting system shall not cause the transducer outputs to exceed the specified CAC.

- 8.1.2.3. The instrumentation response value CFC, as defined in ISO 6487:~~2000~~2002, shall be 180 for all transducers. The CAC response values, as defined in ISO 6487:~~2000~~2002, shall be 50° for the knee bending angle, 10 mm for the shearing displacement and 500 g for the acceleration. This does not require that the impactor itself be able to physically bend and shear to these angles and displacements.

8.1.2.4. Test procedure

- 8.1.2.4.1. The impactor, including foam covering and skin, shall be suspended horizontally by three wire ropes of 1.5 ± 0.2 mm diameter and of ~~2-000~~ mm minimum length, as shown in Figure ~~24~~25. It shall be suspended with its longitudinal axis horizontal, with a tolerance of $\pm 0.5^{\circ}$, and perpendicular to the direction of the certification impactor motion, with a tolerance of $\pm 2^{\circ}$. The impactor shall have the intended orientation about its longitudinal axis, for the correct operation of its knee joint, with a tolerance of $\pm 2^{\circ}$. The impactor must meet the requirements of paragraph 6.3.1.1., with the attachment bracket(s) for the wire ropes fitted.

8.1.2.4.2. The certification impactor shall have a mass of 9.0 ± 0.05 kg, this mass includes those propulsion and guidance components which are effectively part of the impactor during impact. The dimensions of the face of the certification impactor shall be as specified in Figure 2526. The face of the certification impactor shall be made of aluminium, with an outer surface finish of better than 2.0 micrometers.

The guidance system shall be fitted with low friction guides, insensitive to off-axis loading, that allow the impactor to move only in the specified direction of impact, when in contact with the vehicle. The guides shall prevent motion in other directions including rotation about any axis.

8.1.2.4.3. The impactor shall be certified with previously unused foam.

8.1.2.4.4. The impactor foam shall not be excessively handled or deformed before, during or after fitting.

8.1.2.4.5. The certification impactor shall be propelled horizontally at a velocity of 7.5 ± 0.1 m/s into the stationary impactor as shown in Figure 2526. The certification impactor shall be positioned so that its centreline aligns with a position on the tibia centreline of 50 -mm from the centre of the knee, with tolerances ————of ± 3 mm laterally and ± 3 -mm vertically.

8.2. Upper Legform Impactor

8.2.1. The upper legform impactor shall meet the requirements specified in paragraph 8.2.2 when tested as specified in paragraph 8.2.3.

The stabilized temperature of the impactor during certification shall be $20^{\circ} \pm 2^{\circ}$ C.

8.2.2. Requirements

8.2.2.1. When the impactor is propelled into a stationary cylindrical pendulum the peak force measured in each load transducer shall be not less 1.20 kN and not more— than 1.55 -kN and the difference between the peak forces measured in the top and bottom load transducers shall not be more than 0.10 kN. Also, the peak bending moment measured by the strain gauges shall not be less than 190 -Nm and not more than 250 Nm on the centre position and not less than 160 Nm and not more than 220 Nm for the outer positions. The difference between the upper and lower peak bending moments shall not be more than 20 -Nm.

For all these values the readings used shall be from the initial impact with the pendulum and not from the arresting phase. Any system used to arrest the impactor or pendulum shall be so arranged that the arresting phase does not overlap in time with the initial impact. The arresting system shall not cause the transducer outputs to exceed the specified CAC.

8.2.2.2. The instrumentation response value CFC, as defined in ISO 6487:20002002, shall be 180 for all transducers. The CAC response values, as defined in ISO 6487:20002002, shall be 10 kN for the force transducers and 1,000 Nm for the bending moment measurements.

8.2.3. Test procedure

8.2.3.1. The impactor shall be mounted to the propulsion and guidance system, by a torque limiting joint. The torque limiting joint shall be set so that the longitudinal axis of the front member is perpendicular to the axis of the guidance system, with a tolerance of $\pm 2^\circ$, with the joint friction torque set to ~~a minimum of~~ 6750 ± 25 -Nm. The guidance system shall be fitted with low friction guides that allow the impactor to move only in the specified direction of impact, when in contact with the pendulum.

8.2.3.2. The impactor mass shall be adjusted to give a mass of 12 ± 0.1 -kg, this mass includes those propulsion and guidance components which are effectively part of the impactor during impact.

8.2.3.3. The centre of gravity of those parts of the impactor which are effectively forward of the torque limiting joint, including the extra weights fitted, shall lie on the longitudinal centreline of the impactor, with a tolerance of ± 10 mm.

8.2.3.4. The impactor shall be certified with previously unused foam.

8.2.3.5. The impactor foam shall not be excessively handled or deformed before, during or after fitting.

8.2.3.6. The impactor with the front member vertical shall be propelled horizontally at a velocity of 7.1 ± 0.1 -m/s into the stationary pendulum as shown in Figure ~~2627~~.

8.2.3.7. The pendulum tube shall have a mass of 3 ± 0.03 kg, a wall thickness of 3 ± 0.15 mm and an outside diameter of 150 mm ~~+1 -mm/-~~ 4 mm. Total pendulum tube length shall be 275 ± 25 mm. The pendulum tube shall be made from cold finished seamless steel (metal surface plating is permissible for protection from corrosion), with an outer surface finish of better than 2.0 micrometers. It shall be suspended on two wire ropes of 1.5 ± 0.2 -mm diameter and of 2.0 m minimum length. The surface of the pendulum shall be clean and dry. The pendulum tube shall be positioned so that the longitudinal axis of the cylinder is perpendicular to the front member (i.e. level), with a tolerance of $\pm 2^\circ$, and to the direction of impactor motion, with a tolerance of $\pm 2^\circ$, and with the centre of the pendulum tube aligned with the centre of the impactor front member, with tolerances of ± 5 -mm laterally and ± 5 -mm vertically.

8.3. Certification procedure for child and adult headform impactors

8.3.1. Drop test

8.3.1.1. Performance Criteria

The headform impactors shall meet the requirements specified in paragraph 8.3.2. when tested as specified in paragraph 8.3.3.

8.3.2. Requirements

8.3.2.1. When the headform impactors are dropped from a height of 376 \pm 1 mm in accordance with paragraph 8.3.3. the peak resultant acceleration measured by one triaxial (or three uniaxial) accelerometer (accelerometers) in the headform impactor shall be:

- for the child headform impactor not less than 245 g and not more than 300 g;
- for the adult headform impactor not less than 225 g and not more than 275 g.

The acceleration time curve shall be uni-modal.

8.3.2.2. The instrumentation response values CFC and CAC for each accelerometer shall be 1000 Hz and 500 g respectively as defined in ISO 6487: ~~2000~~2002.

8.3.2.3. Temperature conditions

The headform impactors shall have a temperature of 20 \pm 2°C at the time of impact. The temperature tolerances shall apply at a relative humidity of 10 to 70 per cent after a soak period of at least four hours prior to their application in a test.

8.3.2.4. After complying with the certification test, each headform impactor can be used for a maximum of 20 impact tests.

8.3.3. Test Procedure

8.3.3.1. The headform impactor shall be suspended from a drop rig as shown in Figure ~~2728~~.

8.3.3.2. The headform impactor shall be dropped from the specified height by means that ensure instant release onto a rigidly supported flat horizontal steel plate, over 50 mm thick and over 300 mm square which has a clean dry surface and a surface finish of between 0.2 and 2.0 micrometers.

8.3.3.3. The headform impactor shall be dropped with the rear face of the impactor [at the test angle ~~chosen~~ specified in paragraph 7.3.6. for the child headform impactor and in paragraph 7.4.6. for the adult headform impactor ~~XXX~~] with respect to the vertical as shown in Figure ~~2728~~. The suspension of the headform impactor shall be such that it does not rotate during the fall.

8.3.3.4. The drop test shall be performed three times, with the headform impactor rotated 120° around its symmetrical axis after each test.

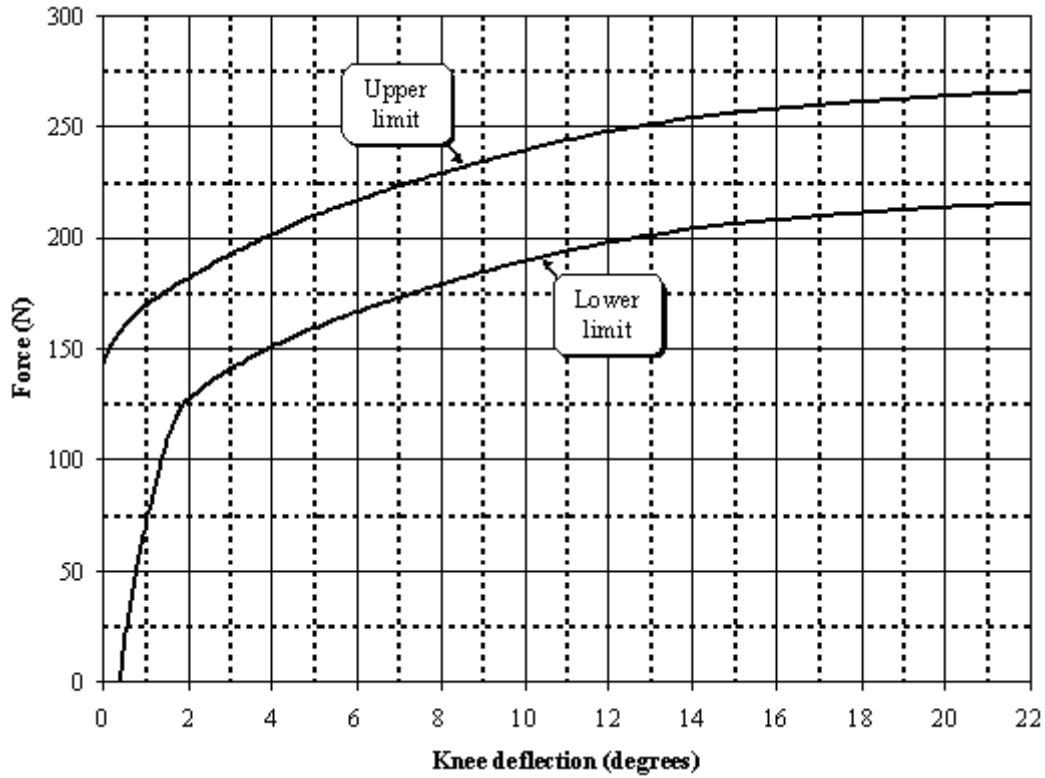

Figure 2021. Force versus angle requirement in static lower legform impactor bending certification test (see §paragraph 8.1.1.2.)

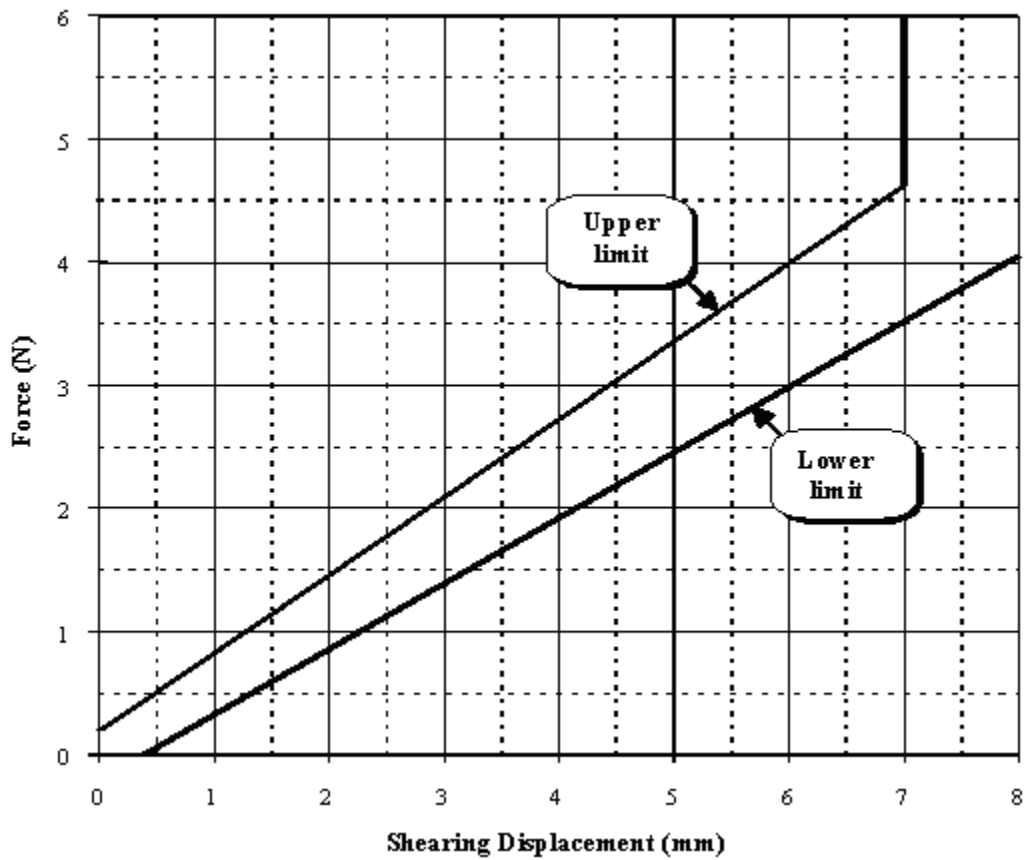

Figure 2122. Force versus displacement requirement in static lower legform impactor shearing certification test (see §paragraph 8.1.1.3.)

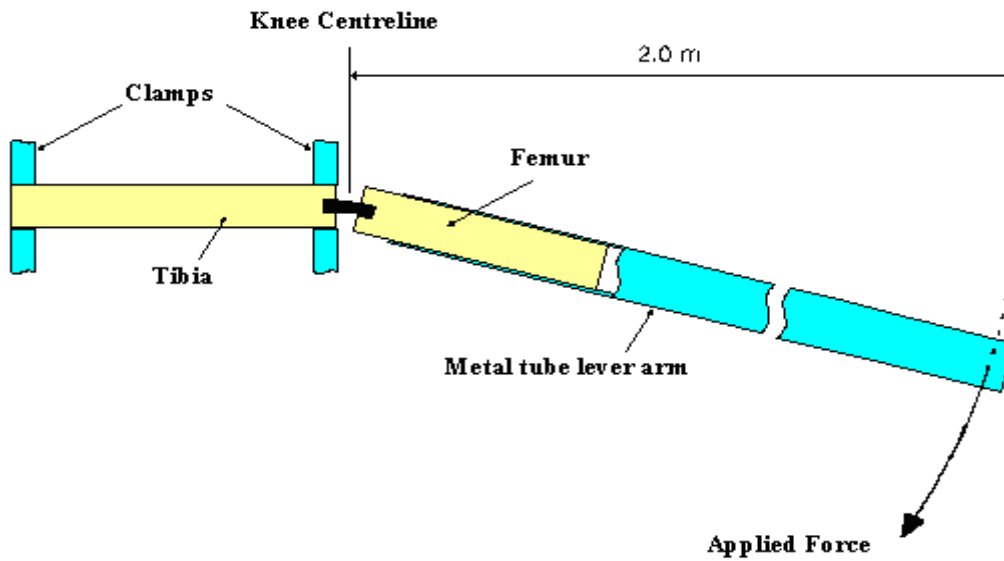

Figure 2223. Top View of Test set-up for static lower legform impactor bending certification test (see §paragraph 8.1.1.4.)

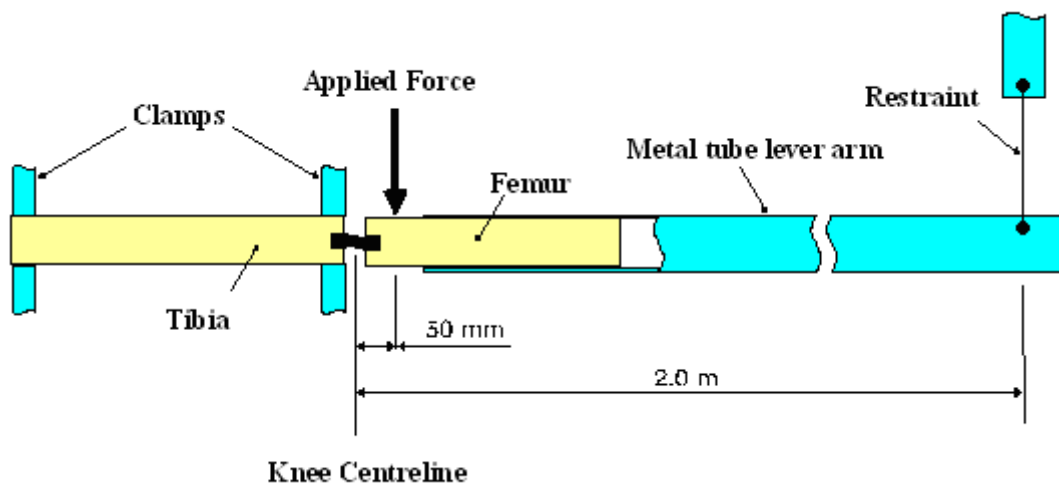

Figure 2324. Top View of Test set-up for static lower legform impactor shearing certification test (see §paragraph 8.1.1.5.)

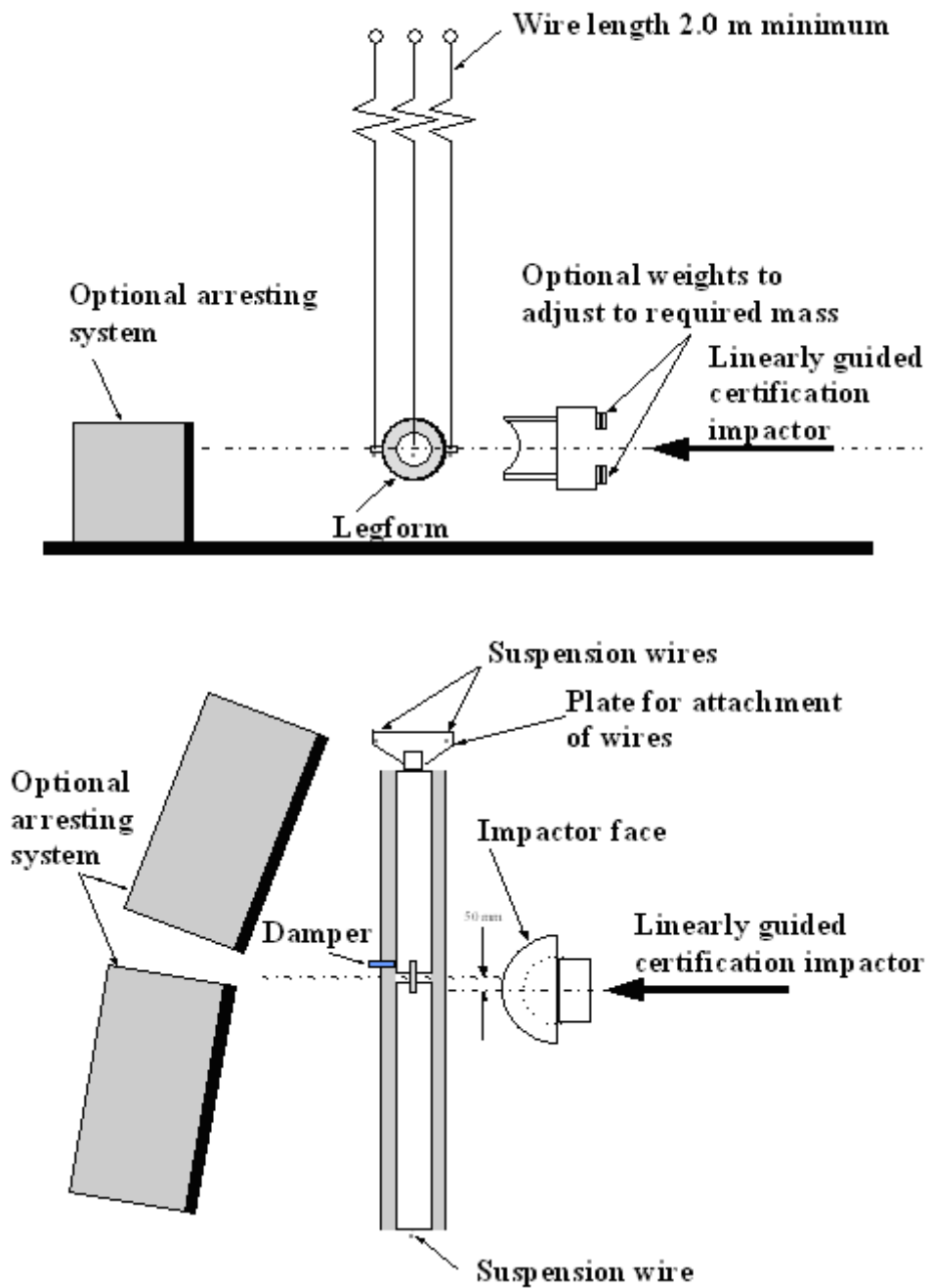

Figure 2425. Test set-up for dynamic lower legform impactor certification test
(side view top diagram, view from above bottom diagram)
(see §paragraph 8.1.2.4.1.)

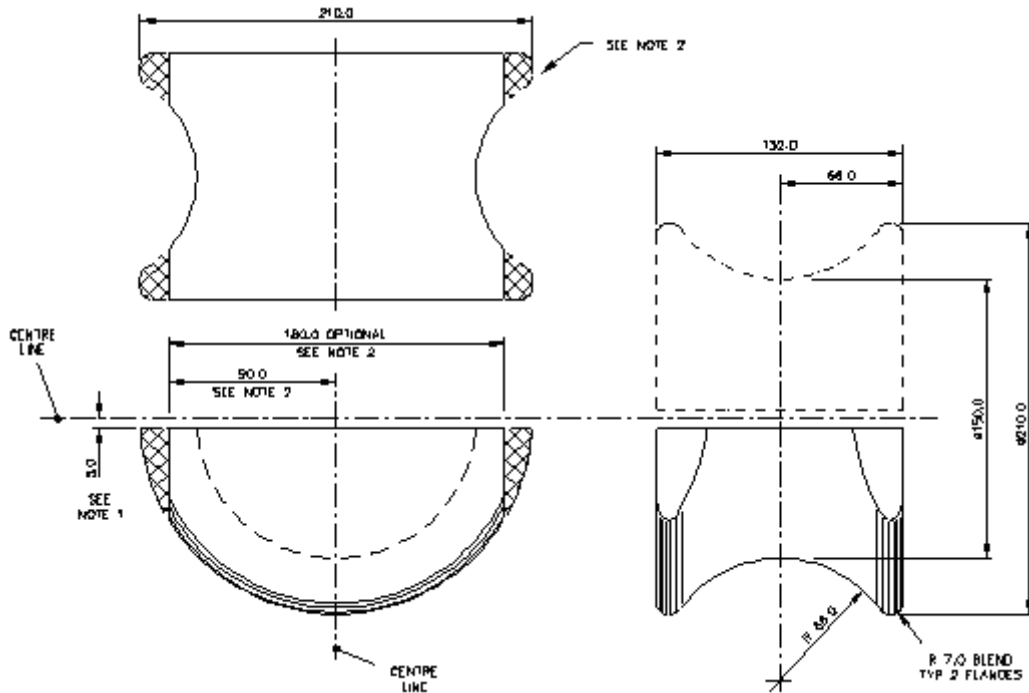

Figure 2526. Details of dynamic lower legform certification impactor face
(see §paragraph- 8.1.2.4.2.)

Notes:

1. Saddle may be made as a complete diameter and cut as shown to make two components.
2. The shaded areas may be removed to give the alternative form shown.
3. Tolerance on all dimensions is ± 1.0 mm.

Material: Aluminium alloy

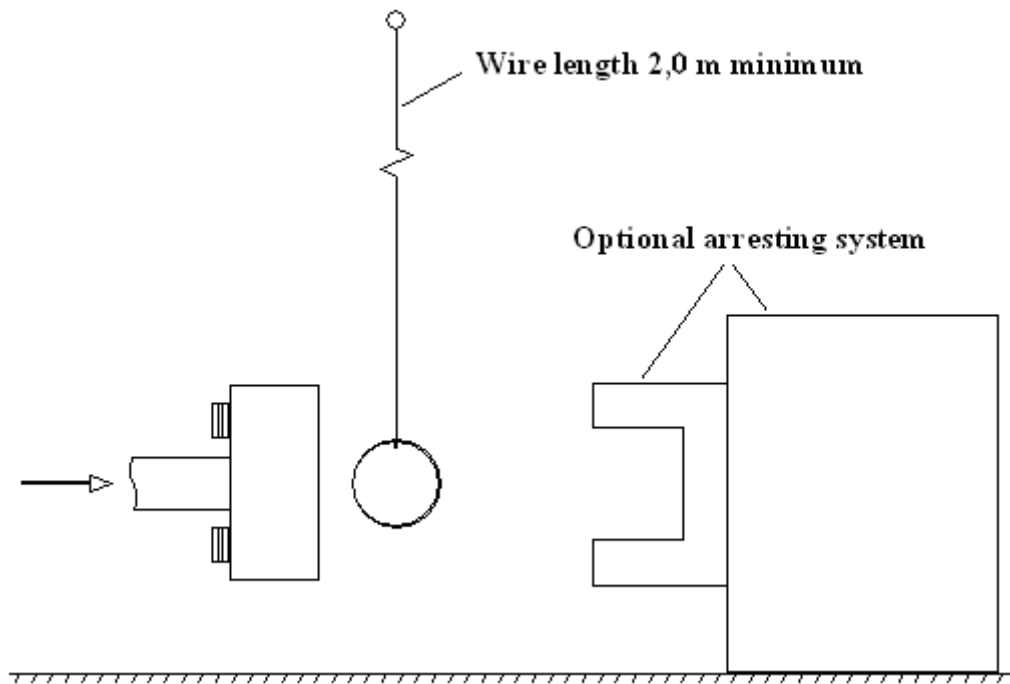

Figure 2627. Test set-up for dynamic upper legform impactor certification test
(see §paragraph- 8.2.3.6)

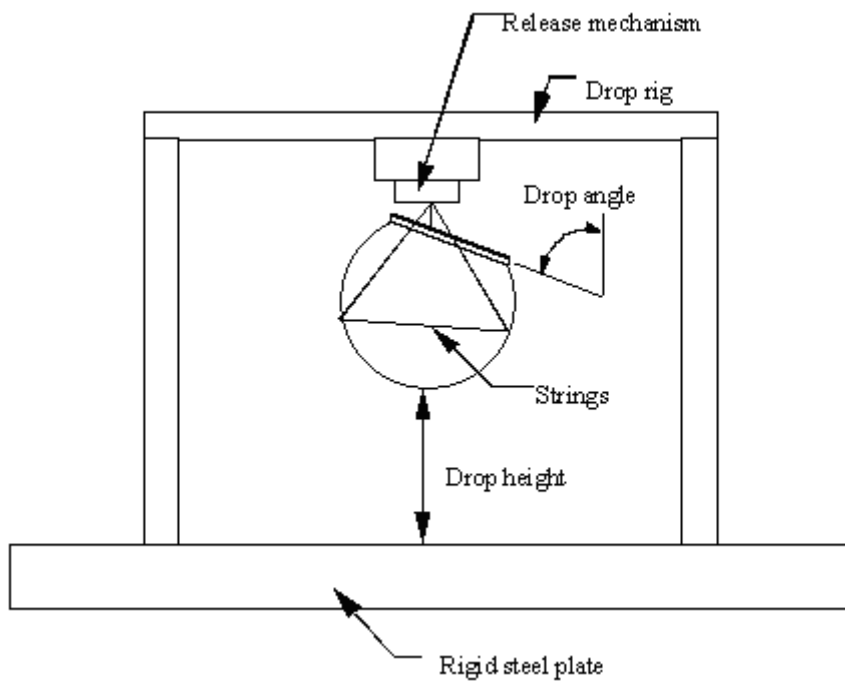

Figure 2728. Test set-up for dynamic headform impactor biofidelity test (see §paragraph 8.3.3.1.)

ANNEX 1: Example of **g**Guidelines for testing active devices designed to protect vulnerable road users when impacted by the vehicle.

ANNEX 2: Impactor handling procedures including:

- soaking conditions
- time between soaking and testing
- time in between tests