



**Economic and Social  
Council**

Distr.  
GENERAL

TRANS/WP.29/GRRF/2005/18  
3 August 2005

ENGLISH ONLY

---

**ECONOMIC COMMISSION FOR EUROPE**

INLAND TRANSPORT COMMITTEE

World Forum for Harmonization of Vehicle Regulations (WP.29)

Working Party on Brakes and Running Gear (GRRF)  
(Fifty-eighth session, 20-23 September 2005,  
agenda item 2.1.)

PROPOSAL FOR DRAFT GLOBAL TECHNICAL REGULATION (GTR):

GLOBAL TECHNICAL REGULATION ON MOTORCYCLE BRAKE SYSTEMS

Transmitted by the expert from Canada

Note: The text reproduced below was prepared by the GRRF Informal Group on Motorcycle Brakes in order to develop a global technical regulation (gtr) on motorcycle braking systems. The text is based on a document without a symbol (working paper No. 12-GTRBE-05), distributed via electronic mail in July 2005.

---

Note: This document is distributed to the experts on Brakes and Running Gear only.

## GLOBAL TECHNICAL REGULATION ON MOTORCYCLE BRAKE SYSTEMS

### 1. SCOPE

This global technical regulation (gtr) specifies requirements for service brakes and, where applicable, associated parking brake systems.

Its purpose is to ensure safe braking performance under normal and emergency riding conditions.

The gtr applies to power driven vehicles with 2 and 3 wheels as summarized in the following table:

Category	Description
3-1	2 wheels, engine < 50 cc and max speed < 50 km/h
3-2	3 wheels, engine < 50 cc and max speed < 50 km/h
3-3	2 wheels, engine > 50 cc or max speed > 50 km/h
3-4	3 wheels – symmetrical, engine > 50 cc or max speed > 50 km/h
3-5	3 wheels – asymmetric, engine > 50 cc or max speed > 50 km/h (motorcycle with sidecar)

- Notes:
- the categories include vehicles with electric power.
  - the categories do not include:
    - (a) vehicles with a maximum speed less than 25 km/h
    - (b) vehicles equipped for disabled drivers

### 2. DEFINITIONS

- 2.1. "Antilock brake system (ABS)" means [a system which senses wheel slip and automatically modulates the pressure producing the braking forces at the wheel(s) to limit the degree of wheel slip.]
- 2.2. "Baseline" test means a stop or a series of stops carried out in order to confirm the performance of the brake prior to subjecting it to a further test e.g. heating procedure or wet brake stop.
- 2.2. "Brake" means the parts of the brake system in which the forces opposing the movement of the vehicle are developed (per ISO 8710).
- 2.3. "Brake system" means the combination of parts (excluding the engine) whose function is progressively to reduce the speed of a moving vehicle, bring it to a halt, and keep it stationary if already halted. The system consists of the control, the transmission, and the brake.

2.4. "Combined brakes system (CBS)" means:

For categories 3-1 and 3-2: a brake system where at least two brakes on different axles are actuated by the operation of a single control.

For categories 3-2 and 3-4: a brake system where the brakes on all axles are actuated by the operation of a single control.

For category 3-5: a brake system where the brakes on at least the front and rear axles are actuated by the operation of a single control. (Where the rear wheel and sidecar wheel are braked simultaneously, this is regarded as the rear brake).

2.5. "Control" means the part actuated directly by the rider in order to supply the energy to the transmission required for braking the vehicle.

2.6. "Controller" means the component designed to evaluate and operate on data transmitted by a sensor and transmit signals to the modulator.

2.7. "Engine disconnected" means when the engine is no longer connected to the driving wheels.

2.8. "Initial brake temperature" means the temperature of the hottest brake 0.32 km before any brake application.

2.9. "Laden" means "gross vehicle mass" (taken from the Special Resolution No. 1 - S.R.1):

This is the maximum mass of the fully laden solo vehicle based on its construction and design performances, as declared by the manufacturer. This shall be less than or equal to the sum of the maximum axles' (group of axles) capacity.

2.10. "Modulator" means component designed to vary braking force in accordance with the signal received from the controller.

2.11. "Peak friction coefficient (PFC)" means the friction of the test surface, measured in accordance with the method specified in national legislation.

2.12. "Sensor" means a component designed to identify and transmit to the controller conditions of rotation of the wheel(s) or other dynamic conditions of the vehicle.

2.13. "Single brake system" means a brake system which acts on only one axle.

2.14. "Split service braking system" means a brake system consisting of two or more subsystems actuated by a single control designed so that a single failure in any subsystem (such as a leakage type failure of a hydraulic subsystem) does not impair the operation of any other subsystem.

- 2.15. "Stopping distance" means distance travelled by the vehicle from the point of application of the control to the point at which the vehicle reaches a full stop.
- 2.16. "Test speed" is the vehicle speed measured at the moment the rider begins to actuate brake system control(s).
- 2.17. "Transmission" means the combination of components that provide the functional link between the control and the brake.
- 2.18. "Unladen" means "mass in running order" (taken from S.R.1):

This is the nominal mass of the vehicle as determined by the following criteria:

- Sum of unladen vehicle mass and driver's mass. The driver's mass is applied in accordance with paragraph 6.1. below:

In the case of category 1-2 vehicles, additional crewmembers for which seating positions are provided shall be included, their mass being equal to, and incorporated in the same way as, that of the driver.

The weight of test equipment including outriggers, if fitted, will be included in the unladen weight.

- 2.19. "V<sub>max</sub>" means the highest speed attainable by accelerating at a maximum rate from a standing start for a distance of 1.6 km on a level surface, with the vehicle in the unladen condition. The vehicle manufacturer may supply this information.
- 2.20. "Wheel lock" is the condition that occurs when there is a slip ratio of 1.00.

Note: In practice, wheel lock is judged to have occurred when the vehicle speed exceeds 15 km/h while the wheel speed falls below 5 km/h at the tyre to road interface (per ISO 12364).

### 3. GENERAL REQUIREMENTS

#### 3.1. Brake system requirements

- 3.1.1. 2-wheeled vehicles (categories 3-1 and 3-3) shall be equipped with two separate service brake systems, or a split service brake system, with at least one brake operating on the front wheel and at least one brake operating on the rear wheel.
- 3.1.2. Category 3-5 vehicles shall have the same brake system requirements as outlined in paragraph 3.1.1. above. A brake on the sidecar wheel is not required providing the vehicle meets the prescribed performance requirements outlined in paragraph 4. of this gtr.
- 3.1.3. 3-wheeled vehicles of categories 3-2 and 3-4 shall be equipped with a parking brake system plus one of the following service brake systems:

- 3.1.3.1. two separate service brake systems which, when applied together, actuate the brakes on all wheels, or
- 3.1.3.2. a service brake system that operates on all wheels and a secondary brake system which may be the parking brake, or
- 3.1.3.3. a split braking system which actuates the brakes on all wheels, actuated through a single control.
- 3.1.4. Where two separate service brake systems are installed, there may be a common brake provided failure in one system does not affect the performance in the other.
- 3.1.5. For vehicles with a hydraulic transmission, the master cylinder shall:
  - have a separate reservoir for each brake system, with its own cover, seal and retention;
  - have a minimum reservoir capacity equivalent to 1.5 times the total fluid displacement required to satisfy the new to fully worn lining condition with the worst case brake adjustment condition;
  - have a reservoir where the fluid level is easily visible for checking without removal of the cover.
- 3.1.6. Vehicles that are equipped with a split service brake system shall be fitted with a red warning lamp, that is mounted in clear view of the rider and which shall be activated:
  - if there is a hydraulic failure when a maximum control force  $\leq 90$  N is applied;
  - without activation of a brake control, when the brake fluid level in the master cylinder reservoir falls below the level specified by the manufacturer or to  $\leq 0.5$  of the fluid reservoir capacity, whichever is the greater.

For function checking, the warning lamp shall be turned on briefly by the activation of the ignition switch.

The warning lamp shall remain on whilst a failure condition exists.

- 3.1.7. Vehicles that are equipped with an ABS system shall be fitted with an amber warning lamp that is mounted in clear view of the rider. The lamp shall be activated whenever there is a malfunction that affects the generation or transmission of response or control signals in the vehicle's ABS system.

For function checking, the warning lamp shall be turned on briefly by the activation of the ignition switch.

The warning lamp shall remain on whilst a failure condition exists.

- 3.1.8. Brake friction material shall not contain asbestos.

3.2. Brake system, general operation

3.2.1. Service brake system

The service brake system shall progressively reduce the speed of the moving vehicle, bring it to a halt, and keep it stationary. The rider shall achieve this whilst seated in the normal driving position and with both hands on the steering control.

3.2.2. Secondary brake system

Where a secondary brake system is fitted, it shall progressively reduce the speed of the moving vehicle to a halt in the event of a failure of the service brake system.

The rider shall achieve this whilst seated in the normal driving position and with at least one hand on the steering control.

3.2.3. Parking brake system

Where a parking brake system is fitted, it must hold the vehicle stationary on the prescribed slope. The parking brake shall:

- (a) have a control which is separate from the service brake controls and;
- (b) be held in the locked position by solely mechanical means.

The rider shall be able to operate the parking brake whilst seated in the normal driving position.

3.3. Durability

3.3.1. The brake system shall take account of friction material wear automatically or by manual means.

3.3.2. The friction material thickness shall be visible without disassembly, but for drum brakes, where the friction material is not visible, wear shall be assessed by means of a device designed for that purpose.

3.3.3. During the tests and on their completion, there shall be no lining detachment and no leakage of brake fluid.

3.4. Measurement of dynamic performance

The method utilized to measure performance shall be as specified in the respective tests in paragraph 4. There are three ways in which the brake performance may be measured:

3.4.1. Mean fully developed deceleration (MFDD)

Calculation of MFDD:

$$d_m = \frac{V_b^2 - V_e^2}{25.92 \cdot (S_e - S_b)} \quad \text{m/s}^2$$

Where:

- $d_m$  = mean fully developed deceleration
- $V_1$  = vehicle speed when rider actuates control
- $V_b$  = vehicle speed at 0.8  $V_1$  in km/h
- $V_e$  = vehicle speed at 0.1  $V_1$  in km/h
- $S_b$  = distance travelled between  $V_1$  and  $V_b$  in metres
- $S_e$  = distance travelled between  $V_1$  and  $V_e$  in metres

3.4.2. Stopping distance

Based on the basic equations of motion:

$$S = 0.1 V + (X) V^2$$

Where:

- S = stopping distance in metres
- V = vehicle speed in km/h
- X = a variable based on the requirement for each test

To calculate the corrected stopping distance using the actual vehicle test speed, the following formula is used:

$$S_s = 0.1 V_s + (S_a - 0.1 V_a) \cdot V_s^2 / V_a^2$$

Where:

- $S_s$  = corrected stopping distance in metres
- $V_s$  = specified vehicle test speed in km/h
- $S_a$  = actual stopping distance in metres
- $V_a$  = actual vehicle test speed in km/h

Note: This equation is only valid when the actual test speed ( $V_a$ ) is within  $\pm 5$  km/h of the specified test speed ( $V_s$ ).

3.4.3. Continuous deceleration recording

For tests such as the wet brake and heat fade – heating procedure, there shall be a continuous recording of the vehicle deceleration from the point where the brake control is applied until the end of the stop.

4. TEST CONDITIONS, PROCEDURES AND PERFORMANCE REQUIREMENTS

4.1. General

4.1.1. Test surfaces

4.1.1.1. Dynamic brake tests (excluding low friction ABS tests):

The test area shall have a clean, dry and level surface, with a gradient  $\leq 1$  per cent.

The surface shall have a nominal peak friction coefficient (PFC) of [0.9 or less], unless otherwise specified.

4.1.1.2. Low friction ABS tests:

Vehicles with ABS shall also be tested on a surface with a peak friction coefficient of  $\leq 0.45$ .

4.1.1.3. Parking brake tests:

The test area shall have a clean, dry and solid surface with the specified slope.

4.1.1.4. Lane width:

For 2 wheeled vehicles (categories 3-1 and 3-3), the lane width shall be 2.5 m.

For 3 wheeled vehicles (categories 3-2, 3-4 and 3-5), the lane width shall be 2.5 m plus the vehicle width.

4.1.2. Ambient temperature

The ambient temperature shall be between 4 °C and 38 °C.

4.1.3. Wind speed

The wind speed shall be not more than 5 m/s.

[4.1.4. Tolerances

Unless otherwise specified, a general tolerance of  $\pm 10$  per cent shall be applied to all test parameters.]

4.1.5. Automatic transmission

Vehicles with automatic transmission shall complete all tests; whether they are for "engine connected" or "engine disconnected".



If an automatic transmission has a neutral position, the neutral position shall be selected for tests where "engine disconnected" is specified.

4.1.6. Vehicle position and wheel lock

The vehicle shall be positioned in the centre of the test lane for the beginning of each stop.

Stops shall be made without the vehicle wheels passing outside the test lane and without wheel lock.

4.1.7. Test sequence

Test order	Paragraph
1. Dry stop - single brake control activated	4.3.
2. Dry stop – all service brake controls activated	4.4.
3. High speed	4.5.
4. Wet brake	4.6.
5. Heat fade <u>1/</u>	4.7.
6. If fitted:	
6.1. Parking brake	4.8.
6.2. ABS	4.9.
6.3. Partial failure, for split brake systems	4.10.
6.4. Servo failure	4.11.

4.2. Preparation

4.2.1. Engine idle speed

Engine idle speed shall be set to the manufacturer's specification.

4.2.2. Tyre pressures

Tyres shall be inflated to the manufacturer's specification for the vehicle loading condition.

4.2.3. Control lever application points and direction

For the hand control lever, the input force (F) shall be applied on the lever's forward surface perpendicular to the axis of the lever fulcrum and its outermost point on the plane along which the brake lever rotates (see figure below).

The input force shall be located 50 mm from the outermost point of the lever, measured along the axis between the central axis of the fulcrum of the lever and its outermost point.

---

1/ Heat fade shall always be the last test carried out.

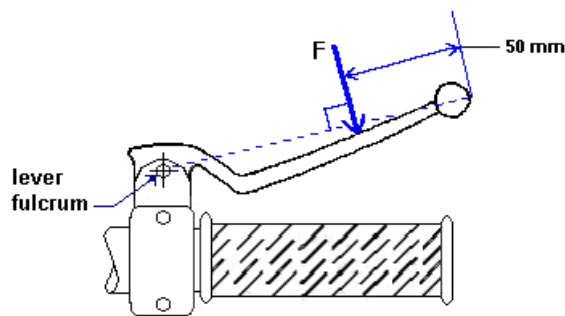

For the foot control pedal, the input force shall be applied to the centre of the pedal and at right angles to the pedal.

#### 4.2.4. Brake temperature measurement

The brake temperature shall be measured on the approximate centre of the braking path of the disc or drum using:

- (a) a rubbing thermocouple that is in contact with the surface of the disc or drum or;
- (b) a thermocouple that is embedded in the friction material.

Contracting Parties may specify which method is acceptable to establish conformity to the requirements.

#### 4.2.5. Burnishing procedure

The manufacture may supply the vehicle for testing with the brakes burnished or the following procedure shall be used:

- Vehicle unladen.
- Engine disconnected.
- Test speed:  
Initial speed  $\geq 50$  km/h;  
Final speed 5 to 10 km/h.
- Brake application:  
Each brake control applied separately.
- Vehicle deceleration:  
Front wheel braking only = 3.0 to 3.5 m/s<sup>2</sup>;  
Rear wheel braking only = 1.5 to 2.0 m/s<sup>2</sup>;  
Combined brake system or split service brake system = 3.5 to 4.0 m/s<sup>2</sup>.

- Number of decelerations: 100 per brake system.
- Initial brake temperature before each brake application  $\leq 100$  °C.
- For the first stop, accelerate the vehicle to the test speed and then activate the brake control under the conditions specified above. Then reaccelerate to the initial test speed and maintain that speed until the brake temperature falls to the specified initial value. When these conditions are met, reapply the brake control as above. Repeat for the number of specified decelerations.

#### 4.3. Dry stop test – single brake control activated

##### 4.3.1. Vehicle condition

- Laden;  
For vehicles fitted with CBS: also unladen.
- Engine disconnected.

##### 4.3.2. Test conditions and procedure

- Initial brake temperature:  $\geq 55$  °C and  $\leq 100$  °C.
- Test speed:  
Category 3-1 and 3-2 vehicles: 40 km/h or 0.9 Vmax, whichever is the lower;  
Category 3-3, 3-4 and 3-5 vehicles: 60 km/h or 0.9 Vmax, whichever is the lower.
- Brake application:  
Each brake control separately.
- Brake actuation force:  
Hand control  $\leq 200$  N;  
Foot control  $\leq 350$  N for vehicles of categories 3-1, 3-2, 3-3 and 3-5;  
 $\leq 500$  N for category 3-4 vehicles.
- Number of stops: until the vehicle meets the performance requirements, with a maximum of 6 stops.
- For each stop, accelerate the vehicle to the test speed and then activate the brake control under the conditions specified above.

##### 4.3.3. Performance requirements

When the brakes have been tested in accordance with the test procedure in paragraph 4.3.2., the stopping distance shall be as specified in column 2 or the MFDD shall be as specified in column 4 of the following table:

Category	Stopping distance(s) (Where V is the specified test speed in km/h and S is the required stopping distance in metres)	or	MFDD
<b>Single front brakes only:</b>			
3-1	$S \leq 0.1 V + V^2/90$		$\geq 3.4 \text{ m/s}^2$
3-2	$S \leq 0.1 V + V^2/70$		$\geq 2.7 \text{ m/s}^2$
3-3	$S \leq 0.1 V + V^2/115$		$\geq 4.4 \text{ m/s}^2$
3-4	$S \leq 0.1 V + V^2/115$		$\geq 4.4 \text{ m/s}^2$
3-5	$S \leq 0.1 V + V^2/95$		$\geq 3.6 \text{ m/s}^2$
<b>Single rear brakes only</b>			
3-1	$S \leq 0.1 V + V^2/70$		$\geq 2.7 \text{ m/s}^2$
3-2	$S \leq 0.1 V + V^2/70$		$\geq 2.7 \text{ m/s}^2$
3-3	$S \leq 0.1 V + V^2/75$		$\geq 2.9 \text{ m/s}^2$
3-4	$S \leq 0.1 V + V^2/75$		$\geq 2.9 \text{ m/s}^2$
3-5	$S \leq 0.1 V + V^2/95$		$\geq 3.6 \text{ m/s}^2$
<b>Vehicles with CBS or split service brake systems: laden and unladen</b>			
3-1 & 3-2	$S \leq 0.1 V + V^2 /115$		$\geq 4.4 \text{ m/s}^2$
3-3	$S \leq 0.1 V + V^2 /132$		$\geq 5.1 \text{ m/s}^2$
3-4	$S \leq 0.1 V + V^2 /130$		$\geq 5.0 \text{ m/s}^2$
3-5	$S \leq 0.1 V + V^2 /140$		$\geq 5.4 \text{ m/s}^2$
<b>Vehicles with CBS – secondary brake only</b>			
All	$S \leq 0.1 V + V^2 /65$		$\geq 2.5 \text{ m/s}^2$

#### 4.4. Dry stop test – all service brake controls activated

##### 4.4.1. Vehicle condition

- Test is applicable to vehicle categories 3-3, 3-4 and 3-5.
- Unladen.
- Engine disconnected.

##### 4.4.2. Test conditions and procedure

- Initial brake temperature  $\geq 55 \text{ }^\circ\text{C}$  and  $\leq 100 \text{ }^\circ\text{C}$ .
- Test speed: 100 km/h or 0.9 Vmax, whichever is the lower.
- Brake application:  
Simultaneous application of both brake controls, if so equipped, or of the single brake control in the case of a service brake system that operates on all wheels.
- Brake actuation force:  
Hand control  $\leq 250 \text{ N}$

Foot control  $\leq 400$  N  
 $\leq 500$  N for category 3-4 vehicles.

- Number of stops: until the vehicle meets the performance requirements, with a maximum of 6 stops.
- For each stop, accelerate the vehicle to the test speed and then apply the brakes under the conditions specified above.

#### 4.4.3. Performance requirements

When the brakes have been tested in accordance with the test procedure in paragraph 4.4.2., the stopping distance (S) shall be [ $\leq 0.1 V + 0.0051V^2$ ]; (where V is the specified test speed in km/h and S is the required stopping distance in metres).

#### 4.5. High speed test

##### 4.5.1. Vehicle condition

- Test is applicable to vehicle categories 3-3, 3-4, 3-5.
- Test is not required for vehicles with  $V_{max} \leq 125$  km/h.
- Unladen.
- Engine connected.

##### 4.5.2. Test conditions and procedure

- Initial brake temperature:  $\geq 55$  °C and  $\leq 100$  °C.
- Test speed:  $0.8 V_{max}$  for vehicles with  $V_{max} > 125$  km/h and  $< 200$  km/h;  
 $160$  km/h for vehicles with  $V_{max} \geq 200$  km/h  $V_{max}$ .
- Brake application:  
Both brake controls shall be activated at the same moment.
- Brake actuation force:  
Hand control  $\leq 200$  N;  
Foot control  $\leq 350$  N for vehicles of categories 3-3 and 3-5;  
 $\leq 500$  N for category 3-4 vehicles.
- Number of stops: until the vehicle meets the performance requirements, with a maximum of 4 stops.

- For each stop, accelerate the vehicle to the test speed and then activate the brake control under the conditions specified above.

#### 4.5.3. Performance requirements

When the brakes have been tested in accordance with the test procedure in paragraph 4.5.2.:

- Stopping distance (S) shall be  $\leq 0.1 V + V^2 / 149$   
(where V is the specified test speed in km/h and S is the required stopping distance in metres)  
  
or the MFDD shall be  $\geq 5.8 \text{ m/s}^2$ .

#### 4.6. Wet brake test

##### 4.6.1. General information

- The test comprises two parts that shall be carried out consecutively for each brake system:
  - (a) A baseline test based on the dry stop test - with single brake control activated (paragraph 4.3.).
  - (b) A single wet brake stop using the same test parameters as in a. above but with the brake(s) being continuously sprayed with water in order to assess the effect of riding in wet conditions.
- The test is not applicable to parking brakes.
- Drum brakes are exempt from this test unless ventilation or open inspection ports are present.
- This test requires the vehicle to be fitted with instrumentation that gives a continuous recording of vehicle deceleration. The MFDD and the stopping distance alternative are not appropriate in this case.

##### 4.6.2. Vehicle condition

- Test is applicable to all vehicle categories.
- Laden:  
For vehicles fitted with CBS: also unladen.
- Engine disconnected.
- Each brake shall be fitted with water spray equipment:

(a) Disc brakes: Sketch of water spray equipment.

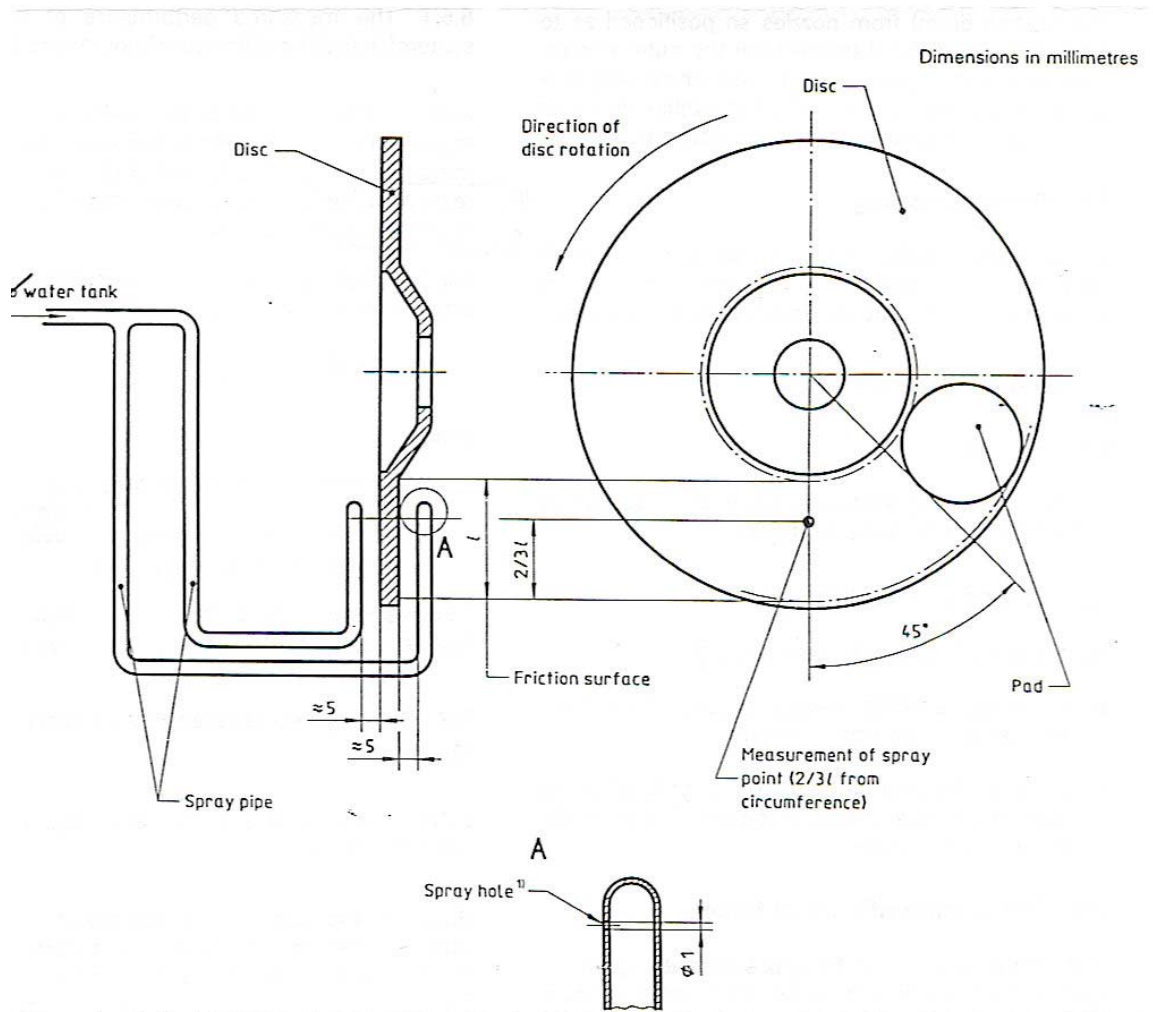

Notes on the installation of the disc brake water spray equipment:

- Water shall be sprayed onto each brake with a flow rate of 15 litres/h. The water shall be equally distributed on each side of the rotor.
- If the surface of the rotor has any shielding, the spray shall be applied 45° prior to the shield.
- If it is not feasible to position the spray at 45° as shown on the sketch, or if the spray coincides with a brake ventilation hole or similar, the spray may be moved 90° max prior to this position.

(b) Drum brakes with ventilation and open inspection ports:

- Water with a flow rate 15 litres/h shall be distributed equally on either side of the drum brake unit (on the stationary back plate and on the rotating drum) from nozzles positioned two thirds of the distance from the outer circumference of the rotating drum to the wheel hub centre.

- The nozzle shall be  $> 15^\circ$  from the edge of any opening in the drum back plate.

#### 4.6.3. Baseline test

- Carry out the test in paragraph 4.3. (dry stop test - with single brake control activated) for each brake system but with a constant brake control force that results in a vehicle deceleration of 2.5 to 3.0 m/s<sup>2</sup>.
- To ensure repeatability:
  - (a) 3 baseline stops shall be performed
  - (b) For each baseline stop, the brake control force and vehicle deceleration shall be recorded. The average brake control force shall be determined for the period between 80 and 10 per cent of the specified test speed.
  - (c) The average of these 3 control force values shall be used for the subsequent wet brake stop.

#### 4.6.4. Wet brake stop

##### 4.6.4.1. Test conditions and procedure:

- (a) The vehicle shall be ridden at the test speed used in the baseline test in paragraph 4.6.3. with the water spray equipment operating on the brake(s) to be tested and with no activation of the brake system.
- (b) After a distance of  $\geq 500$  m, apply the control for the brake system being tested with the average input force derived in the baseline test.

#### 4.6.5. Performance requirements

When tested in accordance with paragraph 4.6.4.1., the wet brake deceleration performance shall be:

$\geq 60$  per cent of the average deceleration performance recorded in the baseline test in the period 0.5 to 1.0 seconds after brake control application.

$\leq 120$  per cent of the average deceleration performance recorded in the baseline test for the complete stop.

#### 4.7. Heat fade test

##### 4.7.1. General information

- The test is comprised of three parts that shall be carried out consecutively for each brake system:
  - (a) A baseline test based on the dry stop test - single brake control activated (paragraph 4.3.);



- (b) A heating procedure which includes a series of repeated stops in order to heat the brake(s);
  - (c) A hot brake stop based on the dry stop test - single brake control activated (paragraph 4.3.), to measure the brake's performance after the heating procedure.
- Test is applicable to vehicle categories 3-3, 3-4 and 3-5.
  - Test is not applicable to parking brakes or secondary brakes.
  - All stops with vehicle laden.
  - The heating procedure requires the vehicle to be fitted with instrumentation that gives a continuous recording of vehicle deceleration and brake actuation control force. The baseline and hot brake stops require the measurement of either MFDD or the stopping distance.

#### 4.7.2. Baseline test

##### 4.7.2.1. Vehicle condition:

- Engine disconnected.

##### 4.7.2.2. Test conditions and procedure:

- Initial brake temperature:  $\geq 55\text{ }^{\circ}\text{C}$  and  $\leq 100\text{ }^{\circ}\text{C}$ .
- Test speed: 60 km/h.
- Brake application:  
Separate test using each brake control.
- Brake actuation force:  
Hand control  $\leq 200\text{ N}$ ;  
Foot control  $\leq 350\text{ N}$  for vehicles of categories 3-3 and 3-5;  
 $\leq 500\text{ N}$  for 3-4 category vehicles.
- Accelerate the vehicle to the test speed, activate the brake control under the conditions specified above, and record the control force to achieve the vehicle braking performance requirements specified in the table in paragraph 4.3.3.

#### 4.7.3. Heating Procedure

##### 4.7.3.1. Test conditions and procedure:

- Initial brake temperature prior to first stop only:  $\geq 55\text{ }^{\circ}\text{C}$  and  $\leq 100\text{ }^{\circ}\text{C}$ .

- Test speed:  
Front brake(s): 100 km/h or 0.7 V<sub>max</sub>, whichever is the lower;  
Rear brake(s): 80 km/h or 0.7 V<sub>max</sub>, whichever is the lower;  
CBS: 100 km/h or 0.7 V<sub>max</sub>, whichever is the lower.
- Brake application:  
Separate test for each brake control.
- Brake actuation force:  
A constant control force that achieves an average vehicle deceleration rate of 3.0 to 3.5 m/s<sup>2</sup> for the duration of the first stop. The brake control force and vehicle deceleration shall be recorded for the duration of the stop. The average brake control force shall be determined for the period between 80 per cent and 10 per cent of the specified test speed.  
The average brake control input force used for the first stop shall be repeated for each of the remaining stops.
- Number of stops: 10.
- Interval between stops: 1000 m.
- Engine transmission:
  - (a) From the test speed to 50 per cent test speed: connected, with the highest gear selected.
  - (b) From 50 per cent test speed to standstill: disconnected.
- Carry out a stop to the conditions specified above and then immediately use maximum acceleration to reach the test speed and maintain that speed until the next stop is made.

#### 4.7.4. Hot brake stop

##### 4.7.4.1. Test conditions and procedure:

Perform a single stop following the conditions used in the baseline test (para. 4.7.2.) for the brake system that has been heated during test in paragraph 4.7.3. This stop shall be carried out within one minute of the completion of test in paragraph 4.7.3. with an average brake actuation force less or equal the average force used in paragraph 4.7.2.

##### 4.7.5. Performance requirements

When the brakes have been tested in accordance with paragraph 4.7.4.1., performance shall be:

If based on MFDD,  $\geq$  60 per cent of the MFDD recorded in the test as specified in paragraph 4.7.2.;

If based on stopping distance, [ $S_2 \leq 1.67 S_1 - 0.67 \times 0.1V$ ].

Where:

$S_1$  = stopping distance in metres achieved in baseline test (para. 4.7.2.);

$S_2$  = stopping distance in metres achieved in hot brake stop (para. 4.7.4.1.);

V = test speed in km/h.

#### 4.8. Parking brake test – for vehicles equipped with parking brakes

##### 4.8.1. Vehicle condition

- Laden.
- Engine disconnected.

##### 4.8.2. Test conditions and procedure

- Initial brake temperature:  $\leq 100$  °C.
- Test surface gradient = 18 per cent.
- Brake actuation force:  
Hand control  $\leq 400$  N;  
Foot control  $\leq 500$  N.
- For the first part of the test, park the vehicle on the test surface gradient facing up the slope by activating the brake system under the conditions specified above. If the vehicle remains stationary, start the measurement of time.
- On completion of the test with vehicle facing up, repeat the same test procedure with the vehicle facing down the gradient.

##### 4.8.3. Performance requirements

When tested in accordance with test procedure specified in paragraph 4.8.2., the parking brake system shall hold the vehicle stationary for 5 minutes in both forward and reverse directions on the gradient.

#### 4.9. ABS tests

##### 4.9.1. General information

- The tests are only applicable to the brake systems of categories 3-1 and 3-3 vehicles that are equipped with an anti-lock brake system (ABS).
- The test series comprises the following individual tests, which may be carried out in any order:

ABS tests	Paragraph
a. Stops on a high friction surface - as used for tests in para. 4.3.	4.9.3.
b. Stops on a low friction surface - $\leq 0.45$	4.9.4.
c. Wheel lock checks on high and low friction surfaces.	4.9.5.
d. Wheel lock check - high to low friction surface transition.	4.9.6.
e. Wheel lock check - low to high friction surface transition.	4.9.7.
f. Stops with an ABS electrical failure.	4.9.8.

#### 4.9.2. Vehicle condition

- Unladen.
- Engine disconnected.

#### 4.9.3. Stops on a high friction surface

##### 4.9.3.1. Test conditions and procedure:

- Initial brake temperature :  $\geq 55$  °C and  $\leq 100$  °C.
- Test speed: 60 km/h or 0.9 Vmax, whichever is lower.
- Brake application:  
Each brake control separately.
- Brake actuation force:  
Hand control = 200 N  $\pm$  10 per cent;  
Foot control = 350 N  $\pm$  10 per cent;  
These forces may be increased in order to ensure ABS cycling.
- Number of stops: until the vehicle meets the performance requirements, with a maximum of 6 stops.
- For each stop, accelerate the vehicle to the test speed and then activate the brake control under the conditions specified above.

##### 4.9.3.2. Performance requirements:

When the vehicle has been tested in accordance with the test procedures in paragraph 4.9.3.1., there shall be no wheel lock [and the stopping distance shall be as specified in column 2 or the MFDD shall be as specified in column 4 of the following table (based on [0.7] x the performance requirements specified in paragraph 4.3.3. – dry stop test – single brake control activated)]:

Category	Stopping distance(s) (Where V is the specified test speed in km/h and S is the required stopping distance in metres)	or	MFDD
For single front brakes only:			
3-1	$S \leq 0.1 V + V^2/64$		$\geq 2.4 \text{ m/s}^2$
3-3	$S \leq 0.1 V + V^2/81$		$\geq 3.1 \text{ m/s}^2$
For single rear brakes only			
3-1	$S \leq 0.1 V + V^2/49$		$\geq 1.9 \text{ m/s}^2$
3-3	$S \leq 0.1 V + V^2/52$		$\geq 2.0 \text{ m/s}^2$
For CBS:			
3-1	$S \leq 0.1 V + V^2/81$		$\geq 3.1 \text{ m/s}^2$
3-3	$S \leq 0.1 V + V^2/93$		$\geq 3.6 \text{ m/s}^2$

#### 4.9.4. Stops on a low friction surface

##### 4.9.4.1. Test conditions and procedure:

Repeat paragraph 4.9.3.1. but using the low friction surface instead of the high friction one.

##### 4.9.4.2. Performance requirements:

When the vehicle has been tested in accordance with the test procedures in paragraph 4.9.4.1., there shall be no wheel lock and the vehicle wheels shall stay within the test lane.

Note: The measurement of stopping distance or MFDD is not required.

#### 4.9.5. Wheel lock checks on high and low friction surfaces

##### 4.9.5.1. Test conditions and procedure:

- Test surfaces:
  - (a) High friction;
  - (b) Low friction.
- Initial brake temperature:  $\geq 55 \text{ }^\circ\text{C}$  and  $\leq 100 \text{ }^\circ\text{C}$ .
- Test speed: 80 km/h or 0.8 Vmax, whichever is lower.
- Brake application:
  - (a) Each brake control separately.
  - (b) Where ABS is fitted to both brake systems, both controls shall also be activated at the same moment.

- Brake actuation force:  
Hand control = 200 N  $\pm$  10 per cent;  
Foot control = 350 N  $\pm$  10 per cent;  
These forces may be increased in order to ensure ABS cycling.
- Brake application rate:  
The brake actuation force shall be applied in 0.2 to 0.5 seconds.
- Number of stops: Maximum of 3 stops.
- For each stop, accelerate the vehicle to the test speed and then activate the brake control under the conditions specified above. The brake control may be released and the test concluded when the vehicle speed has reduced by 20 km/h.
- Record wheel rotation.

#### 4.9.5.2. Performance requirements:

When the vehicle has been tested in accordance with the test procedures in paragraph 4.9.5.1., there shall be no wheel lock and the vehicle wheels shall stay within the test lane.

#### 4.9.6. Wheel lock check - high to low friction surface transition

##### 4.9.6.1. Test conditions and procedure:

- Test surfaces:  
A length of high friction surface immediately followed by a length of low friction surface.
- Initial brake temperature:  $\geq 55$  °C and  $\leq 100$  °C.
- Test speed:  
The speed that will result in 50 km/h or 0.5 V max, whichever is the lower, at the point where the vehicle passes from the high friction to the low friction surface.
- Brake application:
  - (a) Each brake control separately.
  - (b) Where ABS is fitted to both brake systems, both controls shall also be activated at the same moment.
- Brake actuation force:  
Hand control = 200 N  $\pm$  10 per cent;  
Foot control = 350 N  $\pm$  10 per cent;  
These forces may be increased in order to ensure ABS cycling.
- Number of stops: Maximum of 3 stops.

- For each stop, accelerate the vehicle to the test speed and then activate the brake control under the conditions specified above. The brake control may be released and the test concluded when the vehicle speed has reduced by 20 km/h after crossing the surface transition point.
- Record wheel rotation.

#### 4.9.6.2. Performance requirements:

When the vehicle has been tested in accordance with the test procedures in paragraph 4.9.6.1., there shall be no wheel lock and the vehicle wheels shall stay within the test lane.

#### 4.9.7. Wheel lock check - low to high friction surface transition

##### 4.9.7.1. Test conditions and procedure:

- Test surfaces:  
A length of low friction surface immediately followed by a length of high friction surface.
- Initial brake temperature :  $\geq 55$  °C and  $\leq 100$  °C.
- Test speed:  
The speed that will result in 50 km/h or 0.5 Vmax, whichever is the lower, at the point where the vehicle passes from the low friction to the high friction surface.
- Brake application:
  - (a) Each brake control separately;
  - (b) Where ABS is fitted to both brake systems, both controls shall also be activated at the same moment.
- Brake actuation force:  
Hand control = [200 N  $\pm$  10 per cent];  
Foot control = [350 N  $\pm$  10 per cent];  
These forces may be increased in order to promote ABS cycling.
- Number of stops: Maximum of 3 stops.
- For each stop, accelerate the vehicle to the test speed and then activate the brake control under the conditions specified above.
- Record wheel rotation, and the vehicle's continuous deceleration.

4.9.7.2. Performance requirements:

When the vehicle has been tested in accordance with the test procedures in paragraph 4.9.7.1., there shall be no wheel lock and the vehicle wheels shall stay within the test lane.

After passing over the transition point between low and high friction on the test surface, [the vehicle deceleration shall increase].

4.9.8. Stops with an ABS electrical failure

4.9.8.1. Test conditions and procedure:

Carry out the test in paragraph 4.3. (dry stop test – with single brake control activated) applying the conditions relevant to the brake system and vehicle being tested.

4.9.8.2. Performance requirements:

When the brakes have been tested in accordance with test procedure specified in paragraph 4.9.8.1., the minimum requirements for stopping distance or MFDD shall be as specified in the single rear brakes only section of the table in paragraph 4.3.3.

4.10. Partial failure test – for split service brake systems

4.10.1. General information

Test is only applicable to vehicles that are equipped with split service brake systems.

Test is to confirm the performance of the remaining sub system in the event of a hydraulic system leakage failure.

4.10.2. Vehicle condition

- Unladen.
- Engine disconnected.

4.10.3. Test conditions and procedure

- Initial brake temperature:  $\geq 55\text{ }^{\circ}\text{C}$  and  $\leq 100\text{ }^{\circ}\text{C}$ .
- Test speeds: 50 km/h and 100 km/h or 0.8  $V_{\text{max}}$ , whichever is lower.
- Minimum test speed = 25 km/h.
- Brake actuation force:  
Hand control  $\leq 250\text{ N}$ ;



Foot control  $\leq$  400 N.

- Number of stops: until the vehicle meets the performance requirements, with a maximum of 6 tests.
- The service brake system must be altered to induce a complete loss of braking in any one subsystem. Then, for each stop, accelerate the vehicle to the test speed and then apply the brakes under the conditions specified above. Repeat for each subsystem.

#### 4.10.4. Performance requirements

When the brakes have been tested in accordance with the test procedure in paragraph 4.10.3.:

- the system shall comply with the failure warning requirements of paragraph 3.1.6. and;
- stopping distance (S) shall be  $\leq 0.1 V + V^2 / 85$   
(where V is the specified test speed in km/h and S is the required stopping distance in metres)  
or the MFDD shall be  $\geq 3.3 \text{ m/s}^2$ .

#### 4.11. Servo failure test

##### 4.11.1. General information

Test is not required when the vehicle is equipped with another separate service brake system.

Test is to confirm the performance of the brake system in the event of failure of servo assistance.

##### 4.11.2. Test conditions and procedure

Carry out the test in paragraph 4.3. (dry stop test – with single brake control activated), if required, for each brake system with the servo disabled.

##### 4.11.3. Performance requirements

When the brakes have been tested in accordance with test procedure specified in paragraph 4.11.2.: Stopping distance (S) shall be  $\leq 0.1 V + V^2 / 65$

(where  $V$  is the specified test speed in km/h and  $S$  is the corrected stopping distance in metres)  
or the MFDD shall be  $[\geq 2.5\text{m/s}^2]$ .

Note that if the servo is activated by more than one control, the above performance shall be achieved for each control applied separately.

-----