



**Economic and Social  
Council**

Distr.  
GENERAL

TRANS/WP.29/2003/84  
30 July 2003

Original: ENGLISH

---

**ECONOMIC COMMISSION FOR EUROPE**

INLAND TRANSPORT COMMITTEE

World Forum for Harmonization of Vehicle Regulations (WP.29)

(One-hundred-and-thirty-first session,  
11-14 November 2003, agenda item 4.2.21.)

PROPOSAL FOR DRAFT SUPPLEMENT 6 TO THE 03 SERIES OF AMENDMENTS TO  
REGULATION No. 44

(Child restraints)

Transmitted by the Working Party on Passive Safety (GRSP)

Note: The text reproduced below was adopted by GRSP at its thirty-third session, and is transmitted for consideration to WP.29 and to AC.1. It is based on documents TRANS/WP.29/GRSP/2002/10; TRANS/WP.29/GRSP/2003/4; TRANS/WP.29/GRSP/2003/8 and TRANS/WP.29/GRSP/2003/11, all amended (TRANS/WP.29/GRSP/33, paras.28, 30 and annex 3).

---

This document is a working document circulated for discussion and comments. The use of this document for other purposes is the entire responsibility of the user.

Documents are also available via the INTERNET:  
<http://www.unece.org/trans/main/welcwp29.htm>

Insert a new paragraph 2.11.1., to read:

"2.11.1.        "support leg" means a permanent attachment to a child restraint creating a compressive load path between the child restraint and a vehicle structure in order to by-pass seat cushion effects during deceleration; a support leg may be adjustable."

Paragraph 2.14.1., amend to read:

" ... under Regulation No. 14. This includes the trolley floor pan as described in annex 6 or other structural features of a the specific vehicle(s) when loaded by a support leg."

Paragraph 2.23.2., correct the words "look" to read "lock" and "looking" to read "locking".

Insert a new paragraph 2.37., to read:

"2.37.        "Adult safety-belt webbing guide" means a device through which the adult belt passes for its correct routing, that allows free webbing movement."

Paragraph 4.3., amend to read:

"4.3.        If the restraint is to be used in combination with an adult ..... methods of use.

There must be a clear differentiation between the intended routes for the lap section and the diagonal section of the safety belt. Indication such as colour coding, words, shapes etc. shall distinguish each section of the safety belt.

In any illustration of the belt route on the product, the orientation of the child restraint relative to the vehicle must be clearly indicated. Belt route diagrams that do not show the vehicle seat are not acceptable.

The marking defined in this paragraph ..... "

Paragraph 4.4., should be deleted.

Paragraph 4.5. (former), renumber as paragraph 4.4. and amend to read (the label remains unchanged):

"4.4.        On the visible inner surface (including the side wing beside the child's head) in the approximate area where the child's head rests within the child restraint, rearward facing restraints shall have the following .....

This label shall be provided .....

Label minimum size :        60 x 120 mm.

The label shall be stitched to the cover around its entire perimeter and/or permanently bonded to the cover over its entire back surface. Any other form of attachment that is permanent and not liable to removal from the product or to becoming obscured is acceptable. Flag type labels are specifically prohibited.

If sections of the restraint or any accessories supplied by the child restraint manufacturer are able to obscure the label an additional label is required. One warning label shall be permanently visible in all situations when the restraint is prepared for use in any configuration."

Paragraphs 4.6. to 4.9. (former), renumber as paragraphs 4.5. to 4.8.

Insert a new paragraph 6.1.3.7., to read:

"6.1.3.7. Child restraints utilizing a support leg shall only be approved under the "semi-universal" or the "specific vehicle" category and the requirements of annex 11 to this Regulation shall be applied. The manufacturer of the child restraint system shall take into account the needs of the support leg for their correct functioning in each vehicle and provide this information."

Paragraph 6.1.6., amend the reference to "paragraph 1.42." to read "paragraph 1.20."

Insert a new paragraph 7.1.2.2., to read:

"7.1.2.2. In the case of child restraint systems with permanent mechanically attached adjustable head support devices, in which the height of either the adult safety-belt or of the child harness is directly controlled by the adjustable head support, it is not necessary to demand energy absorbing material in areas as defined in annex 18, which are not contactable by the manikin's head, i.e. behind the head support."

Paragraph 7.1.4.1.3., correct the word "preformed" to read "performed".

Paragraph 7.1.4.4.1.1., amend to read:

"7.1.4.4.1.1. Forward facing child restraints: the head of the manikin shall not pass beyond the planes BA and DA as defined in Figure 1 below. This shall be judged up to 300 ms or the moment that the manikin has come to a definitive standstill whatever occurs first.

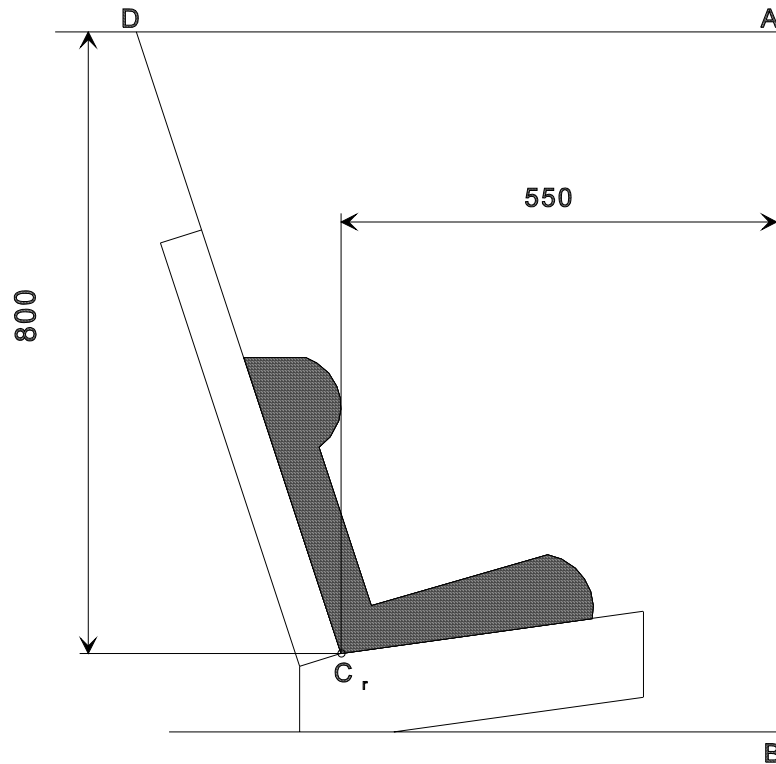

Dimensions in mm

Figure 1

Arrangement for testing a forward-facing device"

Paragraph 7.1.4.4.1.2.1., amend to read:

"7.1.4.4.1.2.1. Child restraints supported by dashboard: the head of the manikin shall not pass beyond the planes AB, AD and DCr, as defined in Figure 2 below. This shall be judged up to 300 ms or the moment that the manikin has come to a definitive standstill whatever occurs first.

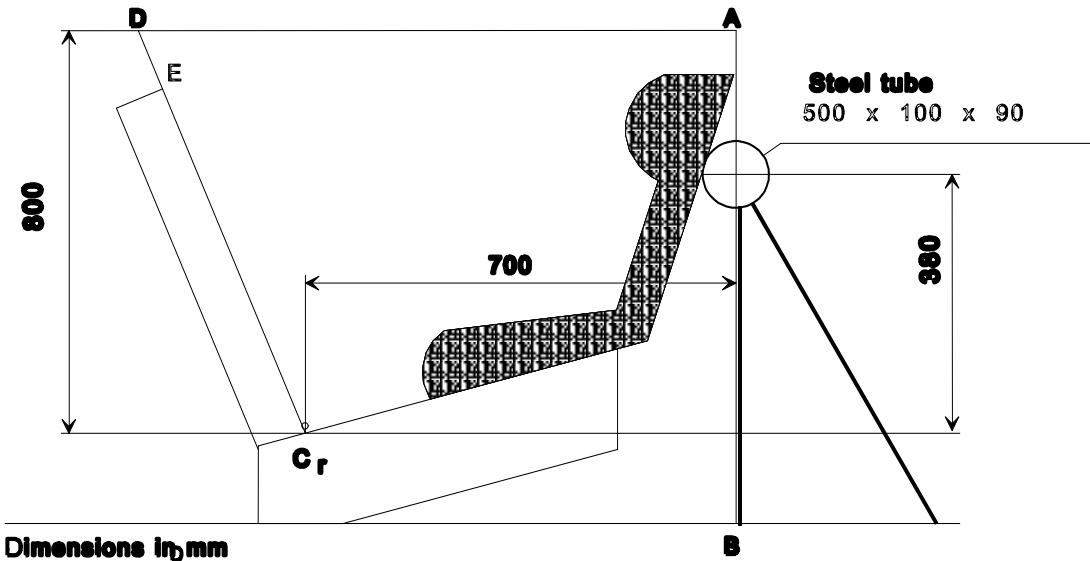

**Figure 2:**  
**Arrangement for testing**  
**a rearward-facing device**

Paragraph 7.1.4.4.1.2.2., amend to read:

"7.1.4.4.1.2.2. Child restraints in group 0 not supported by the dashboard, and carrycots: the head of the manikin shall not pass the planes AB, AD and DE as shown in Figure 3 below. This shall be judged up to 300 ms or the moment that the manikin has come to a definitive standstill whatever occurs first.

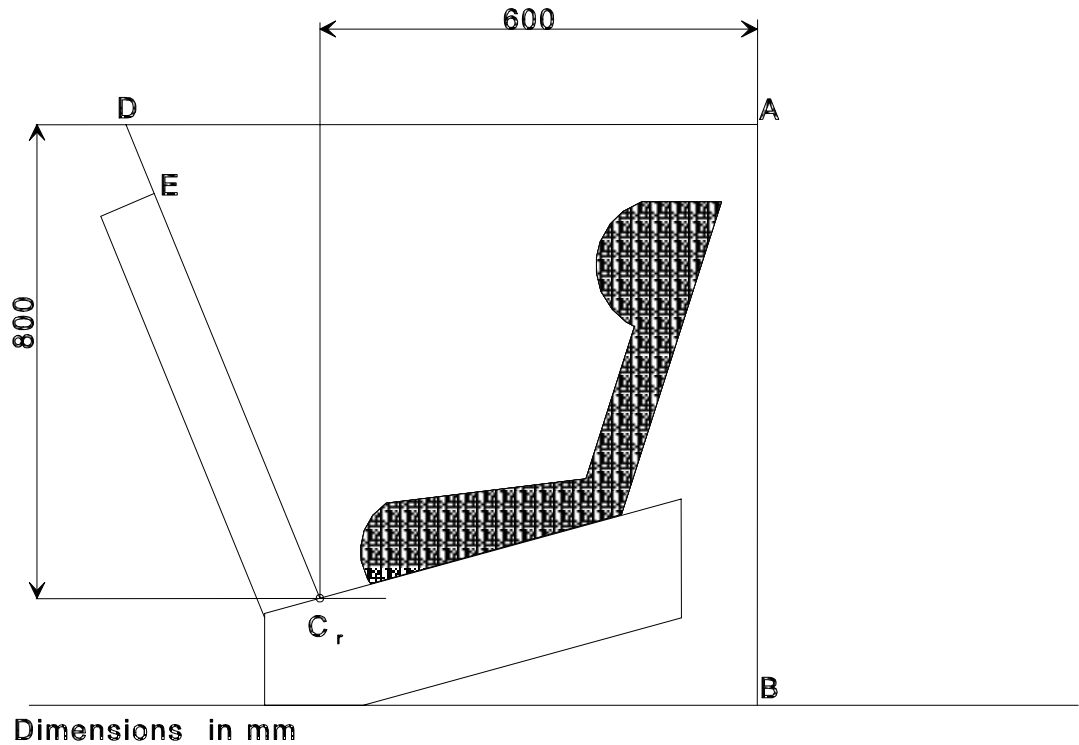

Figure 3

Arrangement for testing child restraint devices group 0,  
not supported by the dashboard"

Paragraph 7.1.4.4.1.2.3., amend to read:

"7.1.4.4.1.2.3. Child restraints other than group 0 not supported by the dashboard:

The head of the manikin shall not pass the planes FD, FG and DE, as shown in Figure 4 below. This shall be judged up to 300 ms or the moment that the manikin has come to a definitive standstill whatever occurs first.

In the case ..... "

Paragraph 7.2.1.2., amend to read:

" ..... in the position of actual unlocking and when projected into a plane perpendicular to the button's initial direction of motion: for enclosed devices an area of ..... two dimensions forming the prescribed area."

Paragraph 7.2.2.1., replace the word "throughout" to read "with all manikins of".

Insert a new paragraph 8.1.3.7.8., to read:

"8.1.3.7.8. If a child restraint system in group 0 or 0+ offers different configurations depending on the mass of the child, each configuration shall be tested with both manikins of the respective mass group."

Paragraph 8.2.1.1.2., amend to read:

" ..... or the vehicle without opening the buckle. A tension of  $200 \pm 2$  N shall be applied to the buckle. If the buckle is attached to a rigid part, the force shall be applied reproducing the angle formed between the buckle and that rigid part during the dynamic test."

Paragraph 9.1., amend to read:

"9.1. The test report shall record the results of all tests and measurements (including the deceleration curve of the trolley and the registration of the time (in msec) when the head of the manikin reaches its maximum displacement during the performance of the dynamic test), and the trolley speeds, the place occupied by the buckle during the tests, if it can be varied, and any failure or breakage."

Annex 6, appendix 3, figures 1 and 2, correct the text reading:

" DISTANCE  $C - R_e = 550$  mm  
ANGLE "ANG" =  $30^\circ$  MAXIMUM",

to read (in each figure):

"DISTANCE  $C - R_e = 530$  mm  
Re is located on the centerline of the retractor spool  
ANGLE "ANG" =  $30^\circ$  MAXIMUM"

Annex 13,

Paragraph 2., amend to read:

" ..... two anchorages points (A1 and A2) (see Figure 1), and a central part (N, in detail in Figure 3). The retractor ....."

Paragraph 3., amend to read:

" .....

Belt retractor R shall be fitted to trolley anchorage such that the spool centre-line is positioned on Re.

The value of X in Figure 1 below is  $200 \pm 5$  mm. The effective strap length between A1 and the centre-line of the retractor spool Re (when the webbing is fully extracted including the minimum length of 150 mm \*/ for testing of universal and semi-universal categories shall be  $2820 \pm 5$  mm when measured in a straight line without load and on a horizontal surface; this length may be increased for testing of restricted category; for all categories with the child restraint installed there shall be a minimum of 150 mm \*/ of strap length on the retractor spool."

Figure 1, amend to read:

"

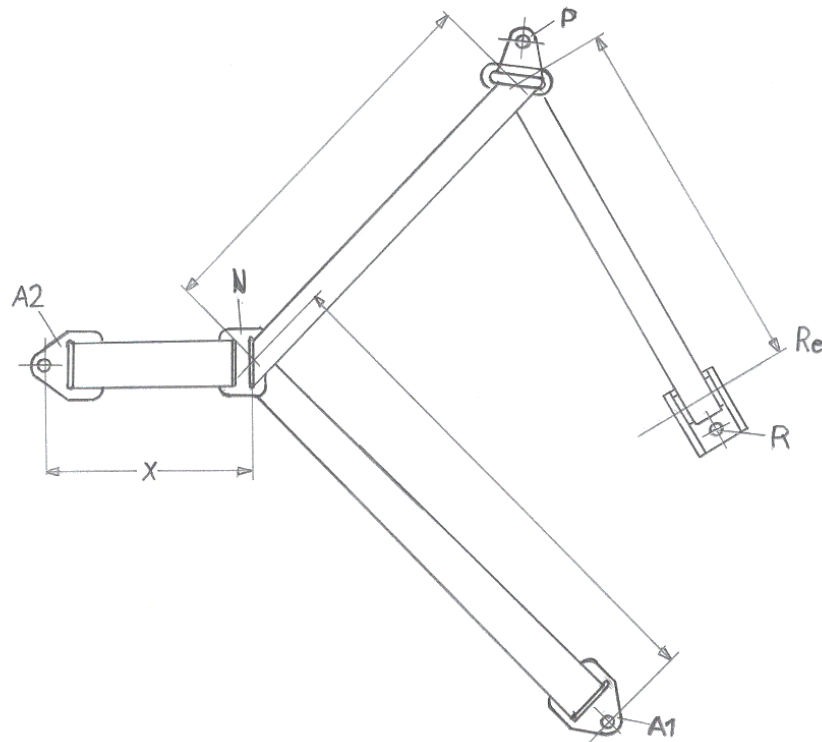

Figure 1: Standard seat belt configurations"



Annex 17,

Paragraphs 3.1. to 3.3., amend to read:

- "3.1. The test shall be conducted on a completely assembled child restraint with a minimum of modification only where necessary to ensure access for the support (directly beneath the point of impact) and for the impactor device and such that there is minimal effect on the performance by the modification.
- 3.2. The assembled child restraint shall be fully supported on its outer surface in the region of impact and be supported directly beneath the point of impact on a smooth rigid base, for example a solid concrete plinth.
- 3.3. Raise the headform to a height of 100  $-0/+5$  mm from the respective upper surfaces of the assembled child restraint to the lowest point on the headform, and allow it to fall. Record the acceleration experienced by the headform during impact."

Annex 18,

Paragraph 1., amend to read:

"..... of the child seat. In the case of carry cot devices where a symmetrical installation of the dummy is not possible according to the device and manufacturer instructions, the lower limit of area at which material complying with annex 17 shall be used, shall be all areas beyond dummy's shoulder in the head direction, when measured with this dummy in the carry cot in its worst position consistent with the manufactures instructions and the carry cot positioned on the test bench.

If a symmetrical installation of the dummy in the carry-cot may be possible, the whole inner surfaces shall be covered with material complying with annex 17; this material has to fulfill its purpose together with the inner side structure; the technical service may assess this aspect with further tests."

---