

ATP HANDBOOK 2018

FOREWORD

1. The ATP Handbook comprises the Agreement itself and its Annexes with comments added where appropriate for clarification or additional explanation of the text.
2. Comments contained in the ATP Handbook are not legally binding for Contracting Parties of the ATP. They are, however, important for the interpretation, harmonization and application of the Agreement as they reflect the opinion of the Working Party on the Transport of Perishable Foodstuffs of the Inland Transport Committee of the Economic Commission for Europe (UNECE).
3. Comments are placed with the provisions of the Agreement to which they refer.
4. Comments do not modify the provisions of the Agreement or of its Annexes but merely make their contents, meaning and scope more precise.
5. Comments provide a means of applying the provisions of the Agreement and of its Annexes so as to take into account the development of technology and economic requirements. They may also describe certain recommended practices.

United Nations Economic Commission for Europe (UNECE)

The United Nations Economic Commission for Europe (UNECE) is one of the five United Nations regional commissions, administered by the Economic and Social Council (ECOSOC). It was established in 1947 with the mandate to help rebuild post-war Europe, develop economic activity and strengthen economic relations among European countries, and between Europe and the rest of the world. During the Cold War, UNECE served as a unique forum for economic dialogue and cooperation between East and West. Despite the complexity of this period, significant achievements were made, with consensus reached on numerous harmonization and standardization agreements.

In the post-Cold War era, UNECE acquired not only many new member States, but also new functions. Since the early 1990s the organization has focused on analyses of the transition process, using its harmonization experience to facilitate the integration of central and eastern European countries into global markets.

UNECE is the forum where the countries of western, central and eastern Europe, Central Asia and North America – 56 countries in all – come together to forge the tools of their cooperation. That cooperation concerns economic cooperation and integration, statistics, environment, transport, trade, sustainable energy, forestry and timber, housing and land management and population. The Commission offers a regional framework for the elaboration and harmonization of conventions, norms and standards. The Commission's experts provide technical assistance to the countries of South-East Europe and the Commonwealth of Independent States. This assistance takes the form of advisory services, training seminars and workshops where countries can share their experiences and best practices.

Transport in UNECE

The UNECE Sustainable Transport Division is the secretariat of the Inland Transport Committee (ITC) and the ECOSOC Committee of Experts on the Transport of Dangerous Goods and on the Globally Harmonized System of Classification and Labelling of Chemicals. The ITC and its 17 working parties, as well as the ECOSOC Committee and its sub-committees are intergovernmental decision-making bodies that work to improve the daily lives of people and businesses around the world, in measurable ways and with concrete actions, to enhance traffic safety, environmental performance, energy efficiency and the competitiveness of the transport sector.

The ECOSOC Committee was set up in 1953 by the Secretary-General of the United Nations at the request of the Economic and Social Council to elaborate recommendations on the transport of dangerous goods. Its mandate was extended to the global (multi-sectoral) harmonization of systems of classification and labelling of chemicals in 1999. It is composed of experts from countries which possess the relevant expertise and experience in the international trade and transport of dangerous goods and chemicals. Its membership is restricted in order to reflect a proper geographical balance between all regions of the world and to ensure adequate participation of developing countries. Although the Committee is a subsidiary body of ECOSOC, the Secretary-General decided in 1963 that the secretariat services would be provided by the UNECE Transport Division.

ITC is a unique intergovernmental forum that was set up in 1947 to support the reconstruction of transport connections in post-war Europe. Over the years, it has specialized in facilitating the harmonized and sustainable development of inland modes of transport. The main results of this persevering and ongoing work are reflected, among other things, (i) in 58 United Nations conventions and many more technical regulations, which are updated on a regular basis and provide an international legal framework for the sustainable development of national and international road, rail, inland water and intermodal transport, including the transport of dangerous goods, as well as the construction and inspection of road motor vehicles; (ii) in the Trans-European North-south Motorway, Trans-European Railway and the Euro-Asia Transport Links projects, that facilitate multi-country coordination of transport infrastructure investment programmes; (iii) in the TIR system, which is a global customs transit facilitation solution; (iv) in the tool called For Future Inland Transport Systems (ForFITS), which can assist national and local governments to monitor carbon dioxide (CO₂) emissions coming from inland transport modes and to select and design climate change mitigation policies, based on their impact and adapted to local conditions; (v) in transport statistics – methods and data – that are internationally agreed on; (vi) in studies and reports that help transport policy development by addressing timely issues, based on cutting-edge research and analysis. ITC also devotes special attention to Intelligent Transport Services (ITS), sustainable urban mobility and city logistics, as well as to increasing the resilience of transport networks and services in response to climate change adaptation and security challenges.

In addition, the UNECE Sustainable Transport and Environment Divisions, together with the World Health Organization (WHO) – Europe, co-service the Transport Health and Environment Pan-European Programme (THE PEP).

Finally, as of 2015, the UNECE Sustainable Transport Division is providing the secretariat services for the Secretary General's Special Envoy for Road Safety, Mr. Jean Todt.

INTRODUCTION

The Agreement on the International Carriage of Perishable Foodstuffs and on the Special Equipment to be Used for such Carriage (ATP) done at Geneva on 1 September 1970 entered into force on 21 November 1976.

The Agreement and its annexes have been regularly amended and updated since their entry into force by the Working Party on the Transport of Perishable Foodstuffs (WP.11) of the Economic Commission for Europe's Inland Transport Committee.

Territorial applicability

The ATP is an Agreement between States, and there is no overall enforcing authority. In practice, highway checks are carried out by Contracting Parties, and non-compliance may then result in legal action by national authorities against offenders in accordance with their domestic legislation. ATP itself does not prescribe any penalties. At the time of publishing, those Contracting Parties are Albania, Andorra, Austria, Azerbaijan, Belarus, Belgium, Bosnia and Herzegovina, Bulgaria, Croatia, Czech Republic, Denmark, Estonia, Finland, France, Georgia, Germany, Greece, Hungary, Ireland, Italy, Kazakhstan, Kyrgyzstan, Latvia, Lithuania, Luxembourg, Monaco, Montenegro, Morocco, Netherlands, Norway, Poland, Portugal, Republic of Moldova, Romania, Russian Federation, San Marino, Saudi Arabia, Serbia, Slovakia, Slovenia, Spain, Sweden, Tajikistan, The former Yugoslav Republic of Macedonia, Tunisia, Turkey, Ukraine, United Kingdom of Great Britain and Northern Ireland, United States of America and Uzbekistan.

Additional practical information

Any query concerning the application of ATP should be directed to the relevant competent authority. Additional information may also be found on the UNECE Transport Division web site at the following link:

<http://www.unece.org/trans/main/wp11/atp.html>

This information, updated on a continuous basis, concerns:

- The status of ATP;
- Depository notifications (e.g. new Contracting Parties, amendments or corrections to legal texts);
- Publication details (corrections, publication of new amendments);
- List and details of competent authorities and ATP Test Stations.

The text below comprises the Agreement itself and its annexes with the latest amendments which enter into force on 6 January 2018.

The amendments or corrections to the Agreement which have become applicable since the last edition of this publication are in Annex I, Appendix 2, paragraphs 1.2, 6.2 and 6.4 and in Annex I, Appendix 2, Model Test Reports No. 1A and No. 10.

TABLE OF CONTENTS

	Page
AGREEMENT ON THE INTERNATIONAL CARRIAGE OF PERISHABLE FOODSTUFFS AND ON THE SPECIAL EQUIPMENT TO BE USED FOR SUCH CARRIAGE (ATP).....	1
 <u>Annex 1</u>	
1. DEFINITIONS OF AND STANDARDS FOR SPECIAL EQUIPMENT FOR THE CARRIAGE OF PERISHABLE FOODSTUFFS	9
1. Insulated equipment	9
2. Refrigerated equipment	9
3. Mechanically refrigerated equipment.....	10
4. Heated equipment	10
5. Mechanically refrigerated and heated equipment	11
6. Transitional measures	11
 Annex 1, Appendix 1	
Provisions relating to the checking of insulated, refrigerated, mechanically refrigerated, heated or mechanically refrigerated and heated equipment for compliance with the standards.....	13
 Annex 1, Appendix 2	
Methods and procedures for measuring and checking the insulating capacity and the efficiency of the cooling or heating appliances of special equipment for the carriage of perishable foodstuffs	19
1. Definitions and general principles.....	19
2. Insulating capacity of equipment.....	22
3. Effectiveness of thermal appliances of equipment	25
4. Procedure for measuring the effective refrigerating capacity W_0 of a unit when the evaporator is free from frost.....	29
5. Checking the insulating capacity of equipment in service	33
6. Verifying the effectiveness of thermal appliances of equipment in service.....	34
7. Procedure for measuring the capacity of mechanical multi-temperature refrigeration units and dimensioning multi-compartment equipment.....	37
8. Test reports	41

Table of contents (cont'd)

	Page
<i>Models of Test Reports</i>	
MODEL No. 1 A.....	43
MODEL No. 1 B.....	45
MODEL No. 2 A.....	47
MODEL No. 2 B.....	49
MODEL No. 3.....	51
MODEL No. 4 A.....	52
MODEL No. 4 B.....	54
MODEL No. 4 C.....	57
MODEL No. 5.....	59
MODEL No. 6.....	61
MODEL No. 7.....	63
MODEL No. 8.....	66
MODEL No. 9.....	68
MODEL No. 10.....	70
MODEL No. 11.....	72
MODEL No. 12.....	74
Annex 1, Appendix 3.....	79
A. Model form of certificate of compliance of the equipment, as prescribed in Annex 1, Appendix 1, paragraph 3.....	79
B. Certification plate of compliance of the equipment, as provided for in Annex 1, Appendix 1, paragraph 3.....	82
Annex 1, Appendix 4	
Distinguishing marks to be affixed to special equipment.....	85

Table of contents (cont'd)

	Page
<u>Annex 2</u>	
SELECTION OF EQUIPMENT AND TEMPERATURE CONDITIONS TO BE OBSERVED FOR THE CARRIAGE OF QUICK (DEEP)-FROZEN AND FROZEN FOODSTUFFS	89
Annex 2, Appendix 1	
Monitoring of air temperatures for transport of quick-frozen perishable foodstuffs	91
Annex 2, Appendix 2	
Procedure for the sampling and measurement of temperature for carriage of chilled, frozen and quick-frozen perishable foodstuffs	93
<u>Annex 3</u>	
SELECTION OF EQUIPMENT AND TEMPERATURE CONDITIONS TO BE OBSERVED FOR THE CARRIAGE OF CHILLED FOODSTUFFS	97

**AGREEMENT ON THE INTERNATIONAL CARRIAGE OF PERISHABLE FOODSTUFFS
AND ON THE SPECIAL EQUIPMENT TO BE USED FOR SUCH CARRIAGE (ATP)**

THE CONTRACTING PARTIES,

DESIROUS of improving the conditions of preservation of the quality of perishable foodstuffs during their carriage, particularly in international trade,

CONSIDERING that the improvement of those conditions is likely to promote the expansion of trade in perishable foodstuffs,

HAVE AGREED as follows:

Chapter I

SPECIAL TRANSPORT EQUIPMENT

Article 1

For the international carriage of perishable foodstuffs, equipment shall not be designated as ‘insulated’, ‘refrigerated’, ‘mechanically refrigerated’, ‘heated’ or ‘mechanically refrigerated and heated’ equipment unless it complies with the definitions and standards set forth in annex 1 to this Agreement.

Article 2

The Contracting Parties shall take the measures necessary to ensure that the equipment referred to in article 1 of this Agreement is inspected and tested for compliance with the said standards in conformity with the provisions of annex 1, appendices 1, 2, 3 and 4, to this Agreement. Each Contracting Party shall recognize the validity of certificates of compliance issued in conformity with annex 1, appendix 1, paragraph 3 to this Agreement by the competent authority of another Contracting Party. Each Contracting Party may recognize the validity of certificates of compliance issued in conformity with the requirements of annex 1, appendices 1 and 2, to this Agreement by the competent authority of a State not a Contracting Party.

Comment:

The issuing of a certificate of compliance by the competent authorities on the basis of test reports is referred to in annex 1, appendix 1, paragraph 3, but there is no indication that such reports had to be issued by a testing station in the country of registration of the equipment.

The test reports in accordance with annex 1, appendix 2 are not certificates. To avoid duplication of the test, each Contracting Party should recognize test stations from any Contracting Party, approved by the competent authority of the country concerned.

Contracting Parties may recognize the test reports, issued by testing stations in countries of non-contracting parties and approved by the competent authority of those countries.

Chapter II

**USE OF SPECIAL TRANSPORT EQUIPMENT FOR THE INTERNATIONAL
CARRIAGE OF CERTAIN PERISHABLE FOODSTUFFS**

Article 3

1. The provisions of article 4 of this Agreement shall apply to all carriage, whether for hire or reward or for own account, carried out exclusively - subject to the provisions of paragraph 2 of this article - by rail, by road or by a combination of the two, of

- quick (deep)-frozen and frozen foodstuffs, and of
- foodstuffs referred to in annex 3 to this Agreement even if they are neither quick (deep)-frozen nor frozen,

if the point at which the goods are, or the equipment containing them is, loaded on to a rail or road vehicle and the point at which the goods are, or the equipment containing them is, unloaded from that vehicle are in two different States and the point at which the goods are unloaded is situated in the territory of a Contracting Party.

In the case of carriage entailing one or more sea crossings other than sea crossings as referred to in paragraph 2 of this article, each land journey shall be considered separately.

2. The provisions of paragraph 1 of this article shall likewise apply to sea crossings of less than 150 km on condition that the goods are shipped in equipment used for the land journey or journeys without transloading of the goods and that such crossings precede or follow one or more land journeys as referred to in paragraph 1 of this article or take place between two such land journeys.

3. Notwithstanding the provisions of paragraphs 1 and 2 of this article, the Contracting Parties need not apply the provisions of article 4 of this Agreement to the carriage of foodstuffs not intended for human consumption.

Comment:

Except in the case of the sea crossings referred to in article 3, paragraph 2, land/sea/land transport, with or without reloading of the goods at the end of the sea crossing(s) is not subject to the provisions of the Agreement if the land transport operations in question are not in themselves of an international nature.

Article 4

1. For the carriage of the perishable foodstuffs specified in annexes 2 and 3 to this Agreement, the equipment referred to in article 1 of this Agreement shall be used unless the temperatures to be anticipated throughout carriage render this requirement manifestly unnecessary for the purpose of maintaining the temperature conditions specified in annexes 2 and 3 to this Agreement. The equipment shall be so selected and used that the temperature conditions prescribed in the said annexes can be complied with throughout carriage. Furthermore, all appropriate measures shall be taken, more particularly as regards the temperature of the foodstuffs at the time of loading and as regards icing or re-icing during the journey or other necessary operations. Nevertheless, the provisions of this paragraph shall apply only in so far as they are not incompatible with international undertakings in the matter of international carriage arising for the Contracting Parties by virtue of conventions in force at the time of the entry into force of this Agreement or by virtue of conventions substituted for them.

2. If during carriage under this Agreement the provisions of paragraph 1 of this article have not been complied with,

- (a) the foodstuffs may not be disposed of in the territory of a Contracting Party after completion of carriage unless the competent authorities of that Contracting Party deem it compatible with the requirements of public health to authorize such disposal and unless such conditions as the authorities may attach to the authorization when granting it are fulfilled; and
- (b) every Contracting Party may, by reason of the requirements of public health or zoonophylaxis and in so far as it is not incompatible with the other international undertakings referred to in the last sentence of paragraph 1 of this article, prohibit the entry of the foodstuffs into its territory or make their entry subject to such conditions as it may determine.

3. Compliance with the provisions of paragraph 1 of this article shall be required of carriers for hire or reward only in so far as they have undertaken to procure or provide services intended to ensure such compliance and if such compliance depends on the performance of those services. If other persons, whether individuals or corporate bodies, have undertaken to procure or provide services intended to ensure compliance with the

provisions of this Agreement, they shall be required to ensure such compliance in so far as it depends on performance of the services they have undertaken to procure or provide.

4. During carriage which is subject to the provisions of this Agreement and for which the loading point is situated in the territory of a Contracting Party, responsibility for compliance with the requirements of paragraph 1 of this article shall rest, subject to the provisions of paragraph 3 of this article,

- in the case of transport for hire or reward, with the person, whether an individual or a corporate body, who is the consignor according to the transport document or, in the absence of a transport document, with the person, whether an individual or a corporate body, who has entered into the contract of carriage with the carrier;
- in other cases with the person, whether an individual or a corporate body, who performs carriage.

Chapter III

MISCELLANEOUS PROVISIONS

Article 5

The provisions of this Agreement shall not apply to carriage in containers classified as thermal maritime by land without transloading of the goods where such carriage is preceded or followed by a sea crossing other than a sea crossing as referred to in article 3, paragraph 2, of this Agreement.

Comment:

Land transport by container classified as a thermal maritime ISO-1496-2 container or container conforming to an equivalent standard, approved by the competent authority of an ATP Contracting Party, preceded or followed by one or more sea crossings, other than those referred to in article 3, paragraph 2, is not subject to the provisions of the Agreement.

Article 6

1. Each Contracting Party shall take all appropriate measures to ensure observance of the provisions of this Agreement. The competent administrations of the Contracting Parties shall keep one another informed of the general measures taken for this purpose.

2. If a Contracting Party discovers a breach committed by a person residing in the territory of another Contracting Party, or imposes a penalty upon such a person, the administration of the first Party shall inform the administration of the other Party of the breach discovered and of the penalty imposed.

Comment:

**QUESTIONNAIRE FOR COLLECTION OF STATISTICS
ON CHECKS CARRIED OUT TO ENSURE COMPLIANCE WITH THE ATP**

Name of Country	Date/Year
1. Number of checks made under Article 6 of ATP:	Road equipment checks: Railway equipment checks: Total:
2. Number of detected breaches	
Domestically registered equipment	Equipment registered in foreign countries⁴
Number of breaches of ATP documents ¹ :	Number of breaches of ATP documents ¹ :
Number of breaches related to thermal appliances	Number of breaches related to thermal appliances
Number of breaches related to the body ²	Number of breaches related to the body ²
Other ATP breaches ³ :	Other ATP breaches ³ :
Total breaches:	Total breaches:
3. Percentage of defective equipment:	
4. Additional information on compliance with the ATP	
Number of 1 st certificates issued: (new equipment only)	
Number of 2 nd certificates issued: (based on inspection by expert) or (based on K values by test stations)	
Number of 3 rd certificates issued: (based on inspection by expert) or (based on K values by test stations)	
Number of 4 th and following certificates: (based on inspection by expert) or	
(based on K values by test stations)	
Total ATP certificates issued:	
Total duplicate certificates issued:	
<u>Notes:</u>	
1/ Including ATP plates and manufacturer's plates (Annex 1, Appendix 1, paragraph 6).	
2/ Seals damaged, holes or cracks.	
3/ Temperature recorder missing, or other.	
4/ This information shall be sent in accordance with Article 6, paragraph 2.	
Signature of the competent authority	

Article 7

The Contracting Parties reserve the right to enter into bilateral or multilateral agreements to the effect that provisions applicable to special equipment and provisions applicable to the temperatures at which certain foodstuffs are required to be maintained during carriage may, more particularly by reason of special climatic conditions, be more stringent than those prescribed in this Agreement. Such provisions shall apply only to international carriage between Contracting Parties which have concluded bilateral or multilateral agreements as referred to in this article. Such agreements shall be transmitted to the Secretary-General of the

United Nations, who shall communicate them to Contracting Parties to this Agreement which are not signatories of the said agreements.

Article 8

Failure to observe the provisions of this Agreement shall not affect either the existence or the validity of contracts entered into for the performance of carriage.

Chapter IV

FINAL PROVISIONS

Article 9

1. States members of the Economic Commission for Europe and States admitted to the Commission in a consultative capacity under paragraph 8 of the Commission's terms of reference may become Contracting Parties to this Agreement

- (a) by signing it;
- (b) by ratifying it after signing it subject to ratification; or
- (c) by acceding to it.

2. States which may participate in certain activities of the Economic Commission for Europe under paragraph 11 of the Commission's terms of reference may become Contracting Parties to this Agreement by acceding thereto after its entry into force.

3. This Agreement shall be open for signature until 31 May 1971 inclusive. Thereafter, it shall be open for accession.

4. Ratification or accession shall be effected by the deposit of an instrument with the Secretary-General of the United Nations.

Comments:

0.9-1 Signature subject to ratification, acceptance or approval

Where the signature is subject to ratification, acceptance or approval, the signature does not establish the consent to be bound. However, it is a means of authentication and expresses the willingness of the signatory state to continue the treaty-making process. The signature qualifies the signatory state to proceed to ratification, acceptance or approval. It also creates an obligation to refrain, in good faith, from acts that would defeat the object and the purpose of the treaty.

0.9-2 Ratification

Ratification defines the international act whereby a state indicates its consent to be bound to a treaty if the parties intended to show their consent by such an act. In the case of bilateral treaties, ratification is usually accomplished by exchanging the requisite instruments, while in the case of multilateral treaties the usual procedure is for the depositary to collect the ratifications of all states, keeping all parties informed of the situation. The institution of ratification grants states the necessary time-frame to seek the required approval for the treaty on the domestic level and to enact the necessary legislation to give domestic effect to that treaty.

0.9-3 Accession

"Accession" is the act whereby a state accepts the offer or the opportunity to become a party to a treaty already

negotiated and signed by other states. It has the same legal effect as ratification. Accession usually occurs after the treaty has entered into force.

Article 10

1. Any State may at the time of signing this Agreement without reservation as to ratification or of depositing its instrument of ratification or accession or at any time thereafter declare by notification addressed to the Secretary-General of the United Nations that the Agreement does not apply to carriage performed in any or in a particular one of its territories situated outside Europe. If notification as aforesaid is made after the entry into force of the Agreement in respect of the notifying State the Agreement shall, ninety days after the date on which the Secretary-General has received the notification, cease to apply to carriage in the territory or territories named in that notification. New Contracting Parties acceding to ATP as from 30 April 1999 and applying paragraph 1 of this article shall not be entitled to enter any objection to draft amendments in accordance with the procedure provided for in article 18, paragraph 2.

2. Any State which has made a declaration under paragraph 1 of this article may at any time thereafter declare by notification addressed to the Secretary-General of the United Nations that the Agreement will be applicable to carriage performed in a territory named in the notification made under paragraph 1 of this article and the Agreement shall become applicable to carriage in that territory one hundred and eighty days after the date on which the Secretary-General has received that notification.

Comments:

0.10-1 Notification

The term "notification" refers to a formality through which a State or an international organisation communicates certain facts or events of legal importance. Notification is increasingly resorted to as a means of expressing final consent. Instead of opting for the exchange of documents or deposit, States may be content to notify their consent to the other party or to the depositary. However, all other acts and instruments relating to the life of a treaty may also call for notifications.

0.10-2 Declarations

Sometimes States make "declarations" as to their understanding of some matter or as to the interpretation of a particular provision. Unlike reservations, declarations merely clarify the state's position and do not purport to exclude or modify the legal effect of a treaty. Usually, declarations are made at the time of the deposit of the corresponding instrument or at the time of signature.

Article 11

1. This Agreement shall come into force one year after five of the States referred to in its article 9, paragraph 1, have signed it without reservation as to ratification or have deposited their instruments of ratification or accession.

2. With respect to any State which ratifies, or accedes to, this Agreement after five States have signed it without reservation as to ratification or have deposited their instruments of ratification or accession, this Agreement shall enter into force one year after the said State has deposited its instrument of ratification or accession.

Article 12

1. Any Contracting Party may denounce this Agreement by giving notice of denunciation to the Secretary-General of the United Nations.

2. The denunciation shall take effect fifteen months after the date on which the Secretary-General received the notice of denunciation.

Article 13

This Agreement shall cease to have effect if the number of Contracting Parties is less than five throughout any period of twelve consecutive months after its entry into force.

Article 14

1. Any State may at the time of signing this Agreement without reservation as to ratification or of depositing its instrument of ratification or accession or at any time thereafter declare by notification addressed to the Secretary-General of the United Nations that this Agreement will be applicable to all or any of the territories for the international relations of which that State is responsible. This Agreement shall be applicable to the territory or territories named in the notification as from the ninetieth day after receipt of the notice by the Secretary-General or, if on that day the Agreement has not yet entered into force, as from its entry into force.

2. Any State which has made a declaration under paragraph 1 of this article making this Agreement applicable to a territory for whose international relations it is responsible may denounce the Agreement separately in respect of that territory in conformity with article 12 hereof.

Article 15

1. Any dispute between two or more Contracting Parties concerning the interpretation or application of this Agreement shall so far as possible be settled by negotiation between them.

2. Any dispute which is not settled by negotiation shall be submitted to arbitration if any one of the Contracting Parties concerned in the dispute so requests and shall be referred accordingly to one or more arbitrators selected by agreement between those Parties. If within three months from the date of the request for arbitration, the Parties concerned in the dispute are unable to agree on the selection of an arbitrator or arbitrators, any of those Parties may request the Secretary-General of the United Nations to designate a single arbitrator to whom the dispute shall be referred for decision.

3. The decision of the arbitrator or arbitrators designated under the preceding paragraph shall be binding on the Contracting Parties concerned in the dispute.

Article 16

1. Any State may, at the time of signing, ratifying, or acceding to, this Agreement, declare that it does not consider itself bound by article 15, paragraphs 2 and 3 of this Agreement. The other Contracting Parties shall not be bound by these paragraphs with respect to any Contracting Party which has entered such a reservation.

2. Any Contracting Party which has entered a reservation under paragraph 1 of this article may at any time withdraw the reservation by notification addressed to the Secretary-General of the United Nations.

3. With the exception of the reservation provided for in paragraph 1 of this article, no reservation to this Agreement shall be permitted.

Comment:

0.16-1 Reservation

A reservation is a declaration made by a State by which it purports to exclude or alter the legal effect of certain provisions of the treaty in their application to that state. A reservation enables a State to accept a multilateral treaty as a whole by giving it the possibility not to apply certain provisions with which it does not want to comply. Reservations can be made when the treaty is signed, ratified, accepted, approved or acceded to. Reservations must not be incompatible with the object and the purpose of the treaty. Furthermore, a treaty might prohibit reservations or only allow for certain reservations to be made.

Article 17

1. After this Agreement has been in force for three years, any Contracting Party may, by notification addressed to the Secretary-General of the United Nations, request that a conference be convened for the purpose of revising this Agreement. The Secretary-General shall notify all Contracting Parties of the request and a revision conference shall be convened by the Secretary-General if, within a period of four months from the date of the notification sent by the Secretary-General, not less than one third of the Contracting Parties signify their assent to the request.
2. If a conference is convened in pursuance of paragraph 1 of this article, the Secretary-General shall so advise all the Contracting Parties and invite them to submit within a period of three months, the proposals which they wish the conference to consider. The Secretary-General shall circulate the provisional agenda for the conference, together with the text of such proposals, to all Contracting Parties not less than three months before the date on which the conference is to open.
3. The Secretary-General shall invite to any conference convened in pursuance of this article all the countries referred to in article 9, paragraph 1, of this Agreement, and also the countries which have become Contracting Parties under the said article 9, paragraph 2.

Comment:

0.17-1 Revision

Some treaties provide for a revision additional to an amendment (i.e., Article 109 of the Charter of the United Nations). In that case, the term "revision" refers to an overriding adoption of the treaty to changed circumstances, whereas the term "amendment" refers only to a change of singular provisions.

Article 18

1. Any Contracting Party may propose one or more amendments to this Agreement. The text of any proposed amendment shall be communicated to the Secretary-General of the United Nations, who shall communicate it to all Contracting Parties and bring it to the notice of all the other States referred to in article 9, paragraph 1, of this Agreement.

The Secretary-General may also propose amendments to this Agreement or to its annexes which have been transmitted to him by the Working Party on the Transport of Perishable Foodstuffs of the Inland Transport Committee of the Economic Commission for Europe.

2. Within a period of six months following the date on which the proposed amendment is communicated by the Secretary-General, any Contracting Party may inform the Secretary-General
 - (a) that it has an objection to the amendment proposed, or
 - (b) that, although it intends to accept the proposal, the conditions necessary for such acceptance are not yet fulfilled in its country.
3. If a Contracting Party sends the Secretary-General a communication as provided for in paragraph 2 (b) of this article, it may, so long as it has not notified the Secretary-General of its acceptance, submit an objection to the proposed amendment within a period of nine months following the expiry of the period of six months prescribed in respect of the initial communication.
4. If an objection to the proposed amendment is stated in accordance with the terms of paragraphs 2 and 3 of this article, the amendment shall be deemed not to have been accepted and shall be of no effect.
5. If no objection to the proposed amendment has been stated in accordance with paragraphs 2 and 3 of this article, the amendment shall be deemed to have been accepted on the date specified below:

- (a) if no Contracting Party has sent a communication to the Secretary-General in accordance with paragraph 2 (b) of this article, on the expiry of the period of six months referred to in paragraph 2 of this article;
- (b) if at least one Contracting Party has sent a communication to the Secretary-General in accordance with paragraph 2 (b) of this article, on the earlier of the following two dates:
 - the date by which all the Contracting Parties which sent such communications have notified the Secretary-General of their acceptance of the proposed amendment, subject however to the proviso that if all the acceptances were notified before the expiry of the period of six months referred to in paragraph 2 of this article the date shall be the date of expiry of that period;
 - the date of expiry of the period of nine months referred to in paragraph 3 of this article.

6. Any amendment deemed to be accepted shall enter into force six months after the date on which it was deemed to be accepted.

7. The Secretary-General shall as soon as possible inform all Contracting Parties whether an objection to the proposed amendment has been stated in accordance with paragraph 2 (a) of this article and whether one or more Contracting Parties have sent him a communication in accordance with paragraph 2 (b) of this article. If one or more Contracting Parties have sent him such a communication, he shall subsequently inform all the Contracting Parties whether the Contracting Party or Parties which have sent such a communication raise an objection to the proposed amendment or accept it.

8. Independently of the amendment procedure laid down in paragraphs 1 to 6 of this article, the annexes and appendices to this Agreement may be modified by agreement between the competent administrations of all the Contracting Parties. If the administration of a Contracting Party has stated that under its national law its agreement is contingent on special authorization or on the approval of a legislative body, the consent of the Contracting Party concerned to the modification of an annex shall not be deemed to have been given until the Contracting Party has notified the Secretary-General that the necessary authorization or approval has been obtained. The agreement between the competent administrations may provide that, during a transitional period, the old annexes shall remain in force, wholly or in part, concurrently with the new annexes. The Secretary-General shall specify the date of the entry into force of the new texts resulting from such modifications.

Comments:

0.18-1 Amendment

The term "amendment" refers to the formal alteration of treaty provisions affecting all the parties to the particular agreement. Such alterations must be effected with the same formalities that attended the original formation of the treaty. Many multilateral treaties lay down specific requirements to be satisfied for amendments to be adopted. In the absence of such provisions, amendments require the consent of all the Parties.

0.18-2 Correction of errors

If, after the authentication of a text, the signatory and Contracting States are agreed that it contains an error, it can be corrected by initialling the corrected treaty text, by executing or exchanging an instrument containing the correction or by executing the corrected text of the whole treaty by the same procedure as in the case of the original text. If there is a depository, the depository must communicate the proposed corrections to all signatory and contracting states. In the UN practice, the Secretary-General, in his function as depository, informs all Parties to a treaty of the errors and the proposal to correct it. If, on the expiry of an appropriate time-limit, no objections are raised by the signatory and Contracting States, the depository circulates a process-verbal of rectification and causes the corrections to be effected in the authentic text(s).

Article 19

In addition to communicating to them the notifications provided for in articles 17 and 18 of this Agreement, the Secretary-General of the United Nations shall notify the States referred to in article 9, paragraph 1, of this Agreement and the States which have become Contracting Parties under article 9, paragraph 2, of:

- (a) signatures, ratifications and accessions under article 9;
- (b) the dates of entry into force of this Agreement pursuant to article 11;
- (c) denunciations under article 12;
- (d) the termination of this Agreement under article 13;
- (e) notifications received under articles 10 and 14;
- (f) declarations and notifications received under article 16, paragraphs 1 and 2;
- (g) the entry into force of any amendment pursuant to article 18.

Article 20

After 31 May 1971, the original of this Agreement shall be deposited with the Secretary-General of the United Nations, who shall transmit certified true copies to each of the States mentioned in article 9, paragraphs 1 and 2, of this Agreement.

IN WITNESS WHEREOF, the undersigned, being duly authorized thereto, have signed this Agreement.

DONE at Geneva, this first day of September, one thousand nine hundred and seventy, in a single copy, in the English, French and Russian languages, the three texts being equally authentic.

Annex I

DEFINITIONS OF AND STANDARDS FOR SPECIAL EQUIPMENT ¹

2. FOR THE CARRIAGE OF PERISHABLE FOODSTUFFS

1. **Insulated equipment.** Equipment of which the body ² is built with rigid* insulating walls, doors, floor and roof, by which heat exchanges between the inside and outside of the body can be so limited that the overall coefficient of heat transfer (K coefficient) is such that the equipment is assignable to one or other of the following two categories:

I_N = Normally insulated equipment specified by: - a K coefficient equal to or less than $0.70 \text{ W/m}^2 \cdot \text{K}$;

I_R = Heavily insulated equipment specified by: - a K coefficient equal to or less than $0.40 \text{ W/m}^2 \cdot \text{K}$ and by side-walls with a thickness of at least 45 mm for transport equipment of a width greater than 2.50 m.

The definition of the K coefficient and a description of the method to be used in measuring it are given in appendix 2 to this annex.

2. **Refrigerated equipment.** Insulated equipment which, using a source of cold (natural ice, with or without the addition of salt; eutectic plates; dry ice, with or without sublimation control; liquefied gases, with or without evaporation control, etc.) other than a mechanical or "absorption" unit, is capable, with a mean outside temperature of $+ 30 \text{ }^\circ\text{C}$, of lowering the temperature inside the empty body to, and thereafter maintaining it:

At $+ 7 \text{ }^\circ\text{C}$ maximum in the case of class A;

At $- 10 \text{ }^\circ\text{C}$ maximum in the case of class B;

At $- 20 \text{ }^\circ\text{C}$ maximum in the case of class C; and

At $0 \text{ }^\circ\text{C}$ maximum in the case of class D.

If such equipment includes one or more compartments, receptacles or tanks for the refrigerant, the said compartments, receptacles or tanks shall:

be capable of being filled or refilled from the outside; and

have a capacity in conformity with the provisions of annex I, appendix 2, paragraph 3.1.3.

The K coefficient of refrigerated equipment of classes B and C shall in every case be equal to or less than $0.40 \text{ W/m}^2 \cdot \text{K}$.

¹ Wagons, lorries, trailers, semi-trailers, containers and other similar equipment.

² In the case of tank equipment, the term "body" means under this definition, the tank itself.

* Rigid in this case refers to non-flexible continuous or non-continuous surfaces, for example full solid walls or roller-shutter doors.

3. **Mechanically refrigerated equipment.** Insulated equipment either fitted with its own refrigerating appliance, or served jointly with other units of transport equipment by such an appliance (fitted with either a mechanical compressor, or an "absorption" device, etc.). The appliance shall be capable, with a mean outside temperature of + 30 °C, of lowering the temperature T_i inside the empty body to, and thereafter maintaining it continuously in the following manner at:

In the case of classes A, B and C, any desired practically constant inside temperature T_i in conformity with the standards defined below for the three classes:

Class A. Mechanically refrigerated equipment fitted with a refrigerating appliance such that T_i may be chosen between + 12 °C and 0 °C inclusive;

Class B. Mechanically refrigerated equipment fitted with a refrigerating appliance such that T_i may be chosen between + 12 °C and - 10 °C inclusive;

Class C. Mechanically refrigerated equipment fitted with a refrigerating appliance such that T_i may be chosen between + 12 °C and - 20 °C inclusive.

In the case of classes D, E and F a fixed practically constant inside temperature T_i in conformity with the standards defined below for the three classes:

Class D. Mechanically refrigerated equipment fitted with a refrigerating appliance such that T_i is equal to or less than 0 °C;

Class E. Mechanically refrigerated equipment fitted with a refrigerating appliance such that T_i is equal to or less than - 10 °C;

Class F. Mechanically refrigerated equipment fitted with a refrigerating appliance such that T_i is equal to or less than - 20 °C. The K coefficient of equipment of classes B, C, E and F shall in every case be equal to or less than 0.40 W/m².K.

4. **Heated equipment.** Insulated equipment, which is capable of raising the inside temperature of the empty body to, and thereafter maintaining it for not less than 12 hours without renewal of supply at, a practically constant value of not less than + 12 °C when the mean outside temperature, is as indicated below:

-10 °C in the case of class A heated equipment;

-20 °C in the case of class B heated equipment;

-30° C in the case of class C heated equipment;

-40° C in the case of class D heated equipment.

Heat producing appliances shall have a capacity in conformity with the provisions of annex 1, appendix 2, paragraphs 3.3.1 to 3.3.5.

The K coefficient of equipment of classes B, C and D shall in every case be equal to or less than 0.40 W/m².K.

5. **Mechanically refrigerated and heated equipment.** Insulated equipment either fitted with its own refrigerating appliance, or served jointly with other units of transport equipment by such an appliance (fitted with either a mechanical compressor, or an 'absorption' device, etc.), and heating (fitted with electric heaters, etc.) or refrigerating-heating units capable both of lowering the temperature T_i inside the empty body and thereafter maintaining it continuously, and of raising the temperature and thereafter maintaining it for not less than 12 hours without renewal of supply at a practically constant value, as indicated below.

Class A: T_i may be chosen between + 12 °C and 0 °C inclusive at a mean outside temperature between -10 °C and +30 °C.

Class B: T_i may be chosen between + 12 °C and 0 °C inclusive at a mean outside temperature between -20 °C and +30 °C.

Class C: T_i may be chosen between + 12 °C and 0 °C inclusive at a mean outside temperature between -30 °C and +30 °C.

Class D: T_i may be chosen between + 12 °C and 0 °C inclusive at a mean outside temperature between -40 °C and +30 °C.

Class E: T_i may be chosen between + 12 °C and -10 °C inclusive at a mean outside temperature between -10 °C and +30 °C.

Class F: T_i may be chosen between + 12 °C and -10 °C inclusive at a mean outside temperature between -20 °C and +30 °C.

Class G: T_i may be chosen between + 12 °C and -10 °C inclusive at a mean outside temperature between -30 °C and +30 °C.

Class H: T_i may be chosen between + 12 °C and -10 °C inclusive at a mean outside temperature between -40 °C and +30 °C.

Class I: T_i may be chosen between + 12 °C and -20 °C inclusive at a mean outside temperature between -10 °C and +30 °C.

Class J: T_i may be chosen between + 12 °C and -20 °C inclusive at a mean outside temperature between -20 °C and +30 °C.

Class K: T_i may be chosen between + 12 °C and -20 °C inclusive at a mean outside temperature between -30 °C and +30 °C.

Class L: T_i may be chosen between + 12 °C and -20 °C inclusive at a mean outside temperature between -40 °C and +30 °C.

The K coefficient of equipment of classes B, C, D, E, F, G, H, I, J, K and L shall in every case be equal to or less than 0.40 W/m².K.

Heat producing or refrigerating-heating appliances when in heating mode shall have a capacity in conformity with the provisions of annex 1, appendix 2, paragraphs 3.4.1 to 3.4.5.

6. **Transitional measures**

- 6.1 Insulated bodies with non-rigid walls which first came into service before the amendment of paragraph 1 of annex 1 entered into force on 6 January 2018 may continue to be used for the carriage of perishable foodstuffs of the appropriate classification until the validity of the certificate of compliance expires. The validity of the certificate shall not be extended.

Annex 1, Appendix 1

PROVISIONS RELATING TO THE CHECKING OF INSULATED, REFRIGERATED, MECHANICALLY REFRIGERATED, HEATED OR MECHANICALLY REFRIGERATED AND HEATED EQUIPMENT FOR COMPLIANCE WITH THE STANDARDS

1. Checks for conformity with the standards prescribed in this annex shall be made:
 - (a) before equipment enters into service;
 - (b) periodically, at least once every six years; and
 - (c) whenever required by the competent authority.

Except in the cases provided for in appendix 2, sections 5 and 6, to this annex, the checks shall be made at a testing station designated or approved by the competent authority of the country in which the equipment is registered or recorded, unless, in the case of the check referred to in (a) above, a check has already been made on the equipment itself or on its prototype in a testing station designated or approved by the competent authority of the country in which the equipment was manufactured.

Comment: This provision therefore means that the check must be carried out at a testing station designated or approved by the competent authority of the country in which the equipment is registered. If the equipment cannot be registered, the check shall be carried out in the country where the equipment is recorded.

Accordingly, the word 'or' does not signify a choice. It means that if the equipment is such that it cannot be registered (e.g. a container), then it must be recorded in the country where the owner of the equipment is based.

This comment applies also to the other provisions containing the words 'registered or recorded'.

2. The methods and procedures to be used in checking for compliance with the standards are described in appendix 2 to this annex.
3. A certificate of compliance with the standards shall be issued by the competent authority of the country in which the equipment is to be registered or recorded. This certificate shall conform to the model reproduced in appendix 3 to this annex.

The certificate of compliance shall be carried on the equipment during carriage and be produced whenever so required by the control authorities. However, if a certification plate of compliance, as reproduced in appendix 3 to this annex, is fixed to the equipment, the certification plate of compliance shall be recognized as equivalent to a certificate of compliance. A certification plate of compliance may be fixed to the equipment only when a valid certificate of compliance is available. Certification plates of compliance shall be removed as soon as the equipment ceases to conform to the standards laid down in this annex.

In the case of equipment transferred to another country, which is a Contracting Party to ATP, it shall be accompanied by the following documents so that the competent authority of the country in which the equipment is to be registered or recorded can issue a certificate of compliance:

- (a) in all cases, the test report of the equipment itself or, in the case of serially produced equipment, of the reference equipment;
- (b) in all cases, the certificate of compliance issued by the competent authority of the country of manufacture or, for equipment in service, the competent authority of the country of registration. This certificate will be treated as a provisional certificate if necessary with a

maximum validity of six months;

- (c) in the case of serially produced equipment, the technical specification of the equipment to be certified as issued by the manufacturer of the equipment or his duly accredited representative (this specification shall cover the same items as the descriptive pages concerning the equipment which appear in the test report and shall be drawn up in at least one of the official languages).

In the case of equipment transferred after it has been in use, the equipment may be subject to a visual inspection to confirm its identity before the competent authority of the country, in which it is to be registered or recorded, issues a certificate of compliance.

For a batch of identical serially produced insulated equipment (containers) having an internal volume of less than 2 m³, a certificate of compliance for the batch may be issued by the competent authority. In such cases the identification numbers of all the insulated equipment, or the first and the last identification numbers of the series, shall be indicated on the certificate of compliance instead of the serial number of each individual unit. In that case, the insulated equipment listed in that certificate shall be fitted with a certification plate of compliance as described in Annex 1, Appendix 3 B issued by the competent authority.

In the case of transfer of this insulated equipment (containers) to another country which is a Contracting Party to this Agreement in order to be registered or recorded there, the competent authority of the country of the new registration or recording may provide an individual certificate of compliance based on the original certificate of compliance established for the whole batch.

Comments to paragraph 3 (c):

While the model ATP certificate is clearly defined in this paragraph, the applications for approval differ from one country to another. It would therefore be useful for a single format to be proposed for all Contracting Parties.

The test report could be drawn up in the national language of the country reissuing the document. It should also be drawn up in at least one of the three official languages of ATP.

4. Distinguishing marks and particulars shall be affixed to the equipment in conformity with the provisions of appendix 4 to this annex. They shall be removed as soon as the equipment ceases to conform to the standards laid down in this annex.
5. The insulated bodies of ‘insulated’, ‘refrigerated’, ‘mechanically refrigerated’, ‘heated’ or ‘mechanically refrigerated and heated’ transport equipment and their thermal appliances shall each bear a durable manufacturer’s plate firmly affixed by the manufacturer in a conspicuous and readily accessible position on a part not subject to replacement in use. It shall be able to be checked easily and without the use of tools. For insulated bodies, the manufacturer’s plate shall be on the outside of the body. The manufacturer’s plate shall show clearly and indelibly at least the following particulars:³

Country of manufacture or letters used in international road traffic;

Name of manufacturer or company;

Model (figures and/or letters);

Serial number;

³ *These requirements shall apply to new plates only. A transitional period of three months shall be granted from the date of entry into force of this requirement.*

Month and year of manufacture.

Comment: ATP checklist

The ATP checklist which appears at the end of this publication in the Section on Examples of Good Practice may serve as guidelines for verifying transport equipment used for the road transport of perishable foodstuffs. The ATP checklist includes basic information regarding the inspection of the isothermal properties of road transport equipment (certificate, certification plate, manufacturer's plate etc.) and the monitoring of air temperatures of quick-frozen perishable foodstuffs. (ECE/TRANS/WP.11/220, para. 39)

6. (a) New equipment of a specific type serially produced may be approved by testing one unit of that type. If the unit tested meets the class specification, the resulting test report shall be regarded as a Type Approval Certificate. This certificate shall expire at the end of a period of six years beginning from the date of completion of the test.

The date of expiry of test reports shall be stated in months and years.

Comment to paragraph 6 (a):

A test report is valid for six years as from the date of the finalisation of the test.

- (b) The competent authority shall take steps to verify that production of other units is in conformity with the approved type. For this purpose it may check by testing sample units drawn at random from the production series.
- (c) A unit shall not be regarded as being of the same type as the unit tested unless it satisfies the following minimum conditions:
- (i) If it is insulated equipment, in which case the reference equipment may be insulated, refrigerated, mechanically refrigerated, heated or mechanically refrigerated and heated equipment,

the construction shall be comparable and, in particular, the insulating material and the method of insulation shall be identical;

Comment 1.1 *Different types of equipment, e.g. trailers, semi-trailers, may be considered as of comparable construction, if other conditions in annex 1, appendix 1, paragraph 6 (c) (i) are satisfied.*

Comment 1.2 *Using different surface materials compared to the reference equipment is allowed, if thickness of the insulating materials is not reduced and if changing the surface material does not reduce the insulating capacity of the body.*

Comment *Recessed interior and exterior fittings mentioned in a test report count as a reduction in the volume of insulating material, and the sum of these volumes may be used for any other minor modifications no matter where they are situated in the unit, as long as the following conditions are met:*

- *the thickness of the remaining insulation material is not less than that of the tested reference equipment at the locations of the fittings; and*
- *the minimum thickness of the remaining insulation material may be locally reduced but shall be at least 20mm.*

In case of modifications, screwed fittings shall be carried out so as to prevent the occurrence of humidity and icing of the modified components. (ECE/TRANS/WP.11/228, para. 68)

the thickness of the insulating material shall be not less than that of the reference equipment;

Comment 2.1 Reducing in some parts of the body the thickness of the insulating material, compared to the reference equipment, and compensating the change by increasing the thickness of the insulating material in some other parts of the body, is not allowed.

the interior fittings shall be identical or simplified;

the number of doors and the number of hatches or other openings shall be the same or less; and

the inside surface area of the body shall not be as much as 20% greater or smaller;

minor and limited modifications of added or exchanged interior and exterior fittings may be permitted:⁴

Comment 1: Minor and limited modifications in this context mean added accessories like load securing rails, wheel arches, lamps etc. which reduce locally the amount and thickness of the insulating material compared to the reference equipment. Reducing the insulating thickness overall, like a whole wall or door, shall not be regarded as minor and limited modifications.

- if the equivalent volume of accumulated insulation material of all such modifications is less than 1/100th of the total volume of the insulating material in the insulated unit;

Comment 2: The total volume of the insulating material shall be calculated by the test station and stated on the test report as the "total reference volume of the insulating material". It shall be the outside volume of the insulated body from which the thicknesses of the outside surface materials are subtracted minus the inside volume of the insulated body to which the thicknesses of inside surface materials are added.

If the inside surface area of the serially produced equipment differs from the reference equipment by not more than 20%, the total volume of the insulating material, from which the 1/100th is calculated, shall be corrected by the same percentage.

- if the K coefficient of the tested reference equipment, corrected by a calculation of the added thermal losses, is less than or equal to the K coefficient limit of the category of the equipment; and
- if such modifications of interior fittings are carried out using the same technique, particularly as concerns glued fittings.

All modifications shall be done by or be approved by the manufacturer of the insulated equipment.

Comment to paragraph 6 (c), (i):

Recessed interior and exterior fittings mentioned in a test report count as a reduction in

⁴ The present provisions regarding minor and limited modifications apply to equipment manufactured after the date of their entry into force (30 September 2015).

the volume of insulating material, and the sum of these volumes may be used for any other minor modifications no matter where they are situated in the unit, as long as the following conditions are met:

the thickness of the remaining insulation material is not less than that of the tested reference equipment at the locations of the fittings; and

the minimum thickness of the remaining insulation material may be locally reduced but shall be at least 20mm.

In case of modifications, screwed fittings shall be carried out so as to prevent the occurrence of humidity and icing of the modified components. (ECE/TRANS/WP.11/228, para. 68)

- (ii) If it is refrigerated equipment, in which case the reference equipment shall be refrigerated equipment,
- the conditions set out under (i) above shall be satisfied;
 - inside circulating fans shall be comparable;
 - the source of cold shall be identical; and
 - the reserve of cold per unit of inside surface area shall be greater or equal;
- (iii) If it is mechanically refrigerated equipment, in which case the reference equipment shall be either:
- (a) mechanically refrigerated equipment;
 - the conditions set out in (i) above shall be satisfied; and
 - the effective refrigerating capacity of the mechanical refrigeration appliance per unit of inside surface area, under the same temperature conditions, shall be greater or equal; or
 - (b) insulated equipment which is complete in every detail but minus its mechanical refrigeration unit which will be fitted at a later date.

The resulting aperture will be filled, during the measurement of the K coefficient, with close fitting panels of the same overall thickness and type of insulation as is fitted to the front wall. In which case:

 - the conditions set out in (i) above shall be satisfied; and
 - the effective refrigerating capacity of the mechanical refrigeration unit fitted to insulated reference equipment shall be as defined in annex 1, appendix 2, paragraph 3.2.6.
- (iv) If it is heated equipment, in which case the reference equipment may be insulated or heated equipment,
- the conditions set out under (i) above shall be satisfied;
 - the source of heat shall be identical; and
 - the capacity of the heating appliance per unit of inside surface area shall be greater or equal.

(v) If it is mechanically refrigerated and heated equipment, in which case the reference equipment shall be:

(a) mechanically refrigerated and heated equipment,

- the conditions set out under (i) above shall be satisfied;

and

- the effective refrigerating capacity of the mechanical refrigeration or mechanical refrigeration-heating appliance per unit of inside surface area, under the same temperature conditions, shall be greater or equal;
- the source of heat shall be identical; and
- the capacity of the heating appliance per unit of inside surface area shall be greater or equal;

or

(b) insulated equipment which is complete in every detail but minus its mechanical refrigeration, heating or mechanical refrigeration-heating appliance, which will be fitted at a later date.

The resulting aperture will be filled, during the measurement of the K coefficient, with close fitting panels of the same overall thickness and type of insulation as are fitted to the front wall, in which case:

- the conditions set out under (i) above shall be satisfied;

and

- the effective refrigerating capacity of the mechanical refrigeration or mechanical refrigeration-heating unit fitted to insulated reference equipment shall be as defined in annex 1, appendix 2, paragraph 3.4.7;
- the source of heat shall be identical; and
- the capacity of the heating appliance per unit of inside surface area shall be greater or equal.

(d) If, in the course of the six-year period, the production series exceeds 100 units, the competent authority shall determine the percentage of units to be tested.

Comment to paragraph 6 (d):

When determining the percentage of units (bodies) to be tested, the competent authority may take into account the manufacturers procedures and quality assurance systems.

Annex I, Appendix 2

METHODS AND PROCEDURES FOR MEASURING AND CHECKING THE INSULATING CAPACITY AND THE EFFICIENCY OF THE COOLING OR HEATING APPLIANCES OF SPECIAL EQUIPMENT FOR THE CARRIAGE OF PERISHABLE FOODSTUFFS

1. DEFINITIONS AND GENERAL PRINCIPLES

- 1.1 K coefficient. The overall heat transfer coefficient (K coefficient) of the special equipment is defined by the following formula:

$$K = \frac{W}{S \cdot \Delta T}$$

where W is either the heating power or the cooling capacity, as the case may be, required to maintain a constant absolute temperature difference ΔT between the mean inside temperature T_i and the mean outside temperature T_e , during continuous operation, when the mean outside temperature T_e is constant for a body of mean surface area S.

- 1.2 The mean surface area S of the body is the geometric mean of the inside surface area S_i and the outside surface area S_e of the body:

$$S = \sqrt{S_i \cdot S_e}$$

In determining the two surface areas S_i and S_e , structural peculiarities and surface irregularities of the body, such as chamfers, wheel-arches and similar features, shall be taken into account and shall be noted under the appropriate heading in test reports; however, if the body is covered with corrugated sheet metal the area considered shall be that of the plane surface occupied, not that of the developed corrugated surface.

For calculating the mean surface area of the body of a panel van, the test station appointed by the competent authority shall select from one of the following three methods.

Method A. The manufacturer shall provide drawings and calculations of the inside and outside surfaces.

The surface areas S_e and S_i are determined taking into consideration the projected surface areas of specific design features of the irregularities of its surface such as curves, corrugations, wheel boxes, etc.

Method B. The manufacturer shall provide drawings and the test station appointed by the competent authority shall use the calculations according to the schemes⁵ and formulae below.

$$S_i = (((WI \times LI) + (WI \times LI) + (Wi \times Wi)) \times 2)$$

$$S_e = (((WE \times LE) + (WE \times LE) + (We \times We)) \times 2)$$

Where:

WI is the Y axis of the internal surface area

LI is the X axis of the internal surface area

⁵ The relevant figures can be found in the ATP Handbook at the following link: http://www.unece.org/trans/main/wp11/atp_handbook.html

Wi is the Z axis of the internal surface area

WE is the Y axis of the external surface area

LE is the X axis of the external surface area

We is the Z axis of the external surface area

Using the most appropriate formula for the Y axis of the internal surface area

$$WI = (WLa \times a + Wlb \times (b + c/2) + Wlc \times c/2) / (a + b + c)$$

$$WI = (WLa \times a/2 + Wlb (a/2 + b/2) + Wlc (b/2)) / (a + b)$$

$$WI = ((Wlb \times b) + (Wlb \times c) - ((Wlb - Wlc) \times c) + (2 \times ((Wlb - WLa) \times a))) / (a + b + c)$$

Where:

WLa is the internal width at the floor or between the wheel arches

Wlb is the internal width at the height of the vertical edge from the floor or above the wheel arches.

Wlc is the internal width along the roof

a is the height of the vertical edge from the floor

b is either the height between the bottom of the vertical edge and the roof or between the top of the wheel arch and the top of the vertical edge from the floor.

c is the height between the roof and point b

Along with the two formulae for the X and Z axes of the internal surface:

$$LI = ((LLa \times a) + (Llb + Llc) / 2 \times b + (Llc \times c)) / (a + b + c)$$

Where:

LLa is the internal length along the floor

Llb is the internal length above the wheel arches

Llc is the internal length along the roof

a is the height between LLa and Llb

b is the height between Llb and Llc

c is the height between Llc and the roof

$$Wi = (Wi \text{ back} + Wi \text{ front}) / 2$$

Where:

Wi back is the width at the bulkhead

Wi front is the width at the door end

The external surface area is calculated using the formulae below

$$WE = WI + \text{declared mean thickness}$$

$$LE = LI + \text{declared mean thickness}$$

$$We = Wi + \text{declared mean thickness}$$

Method C. If neither of the above is acceptable to the experts, the internal surface shall be measured according to the figures and formulae in method B.

The K value shall then be calculated based on the internal surface area, taking the insulation thickness as nil. From this K value, the average insulation thickness is calculated from the assumption that λ for the insulation has a value of 0.025 W/m·K.

$$d = Si \times \Delta T \times \lambda / W$$

Once the thickness of the insulation has been estimated, the external surface area is calculated and the mean surface area is determined. The final K value is derived from successive iteration.

Figure 1

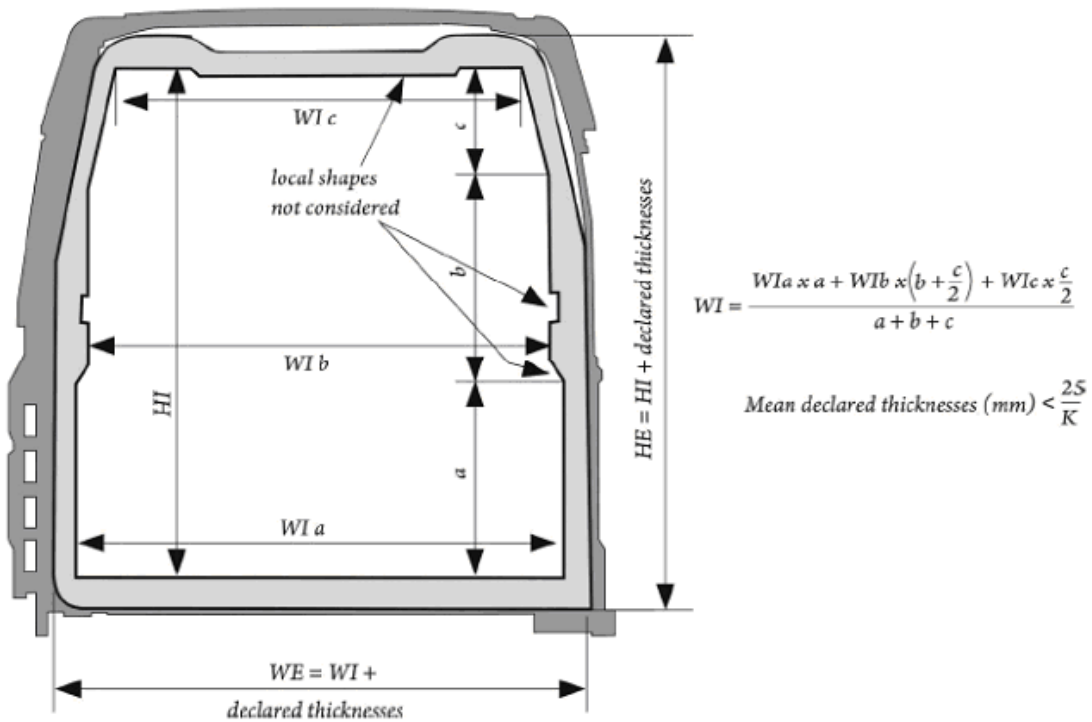

Figure 2

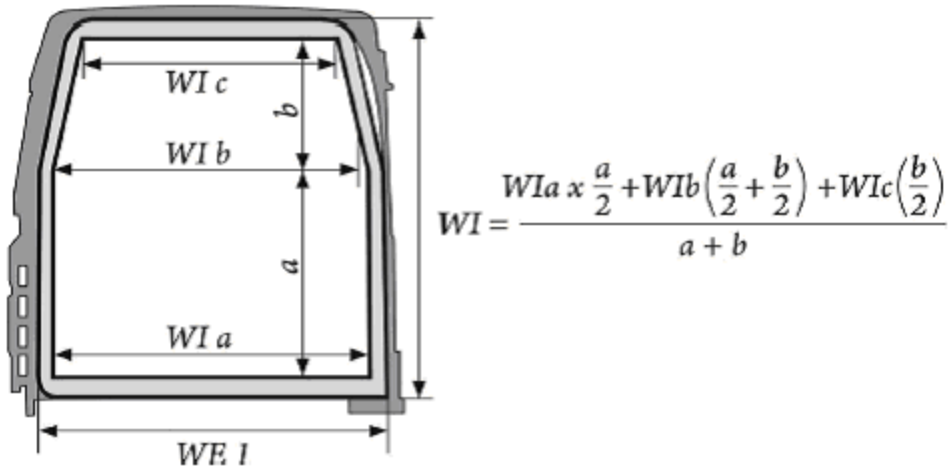
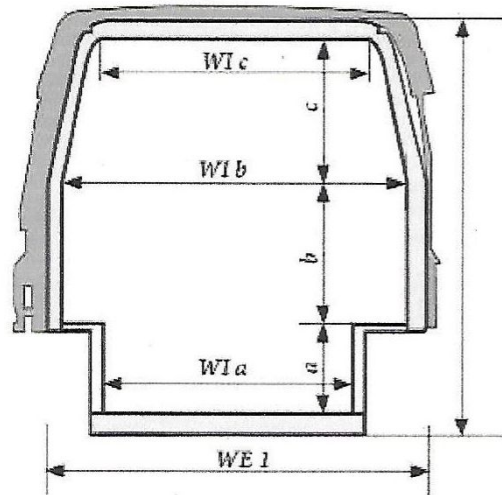

Figure 3



$WE = WI + \text{mean declared thicknesses}$

$$WI = \frac{((Wlbxb) + (Wlbcx) - ((Wlb - Wlc)xc) + (Wlba) + (2x((Wlb - Wla)xa)))}{(a+b+c)}$$

key

W_{ia} internal width between the wheel arches

W_{ib} internal width above the wheel arches

W_{ic} internal width of the roof

a internal height of the wheel arches

b internal height above the wheel arches

c internal height above the wheel arches where the side wall width ends

Figure 4

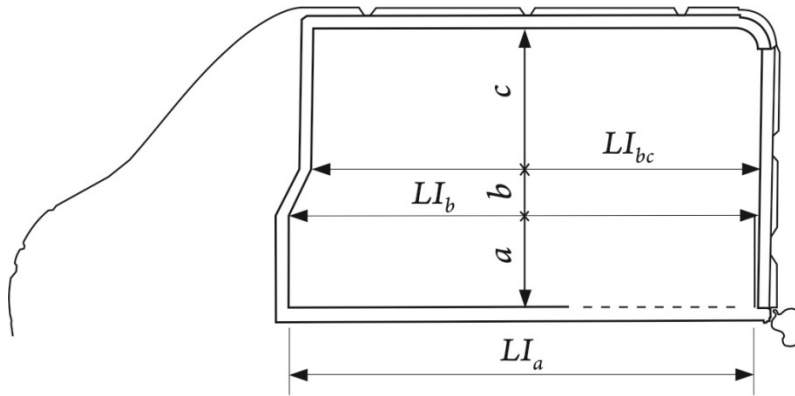

$$LI = \frac{(LI_a \times a) + (LI_b + LI_c) / 2 \times b + (LI_c \times c)}{a + b + c}$$

$$LE = LI + \text{mean declared thicknesses}$$

Figure 5

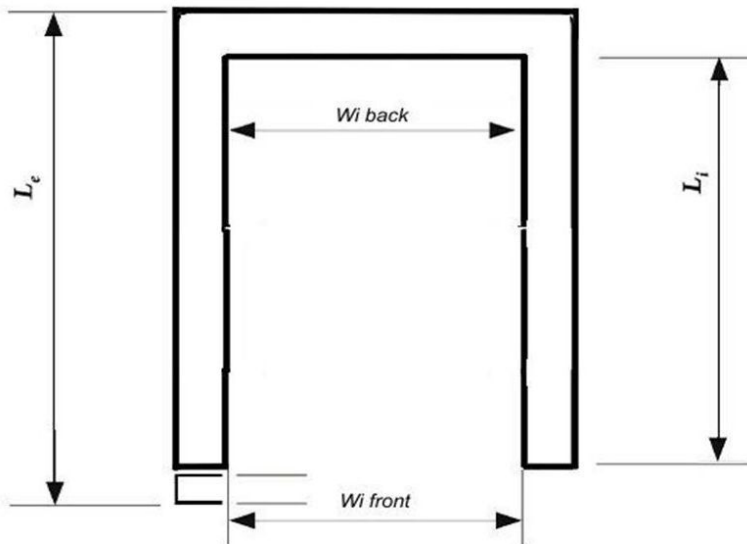

$$Wi = \frac{(Wi\ back + Wi\ front)}{2}$$

$$We = Wi + \text{mean declared thickness}$$

Examples

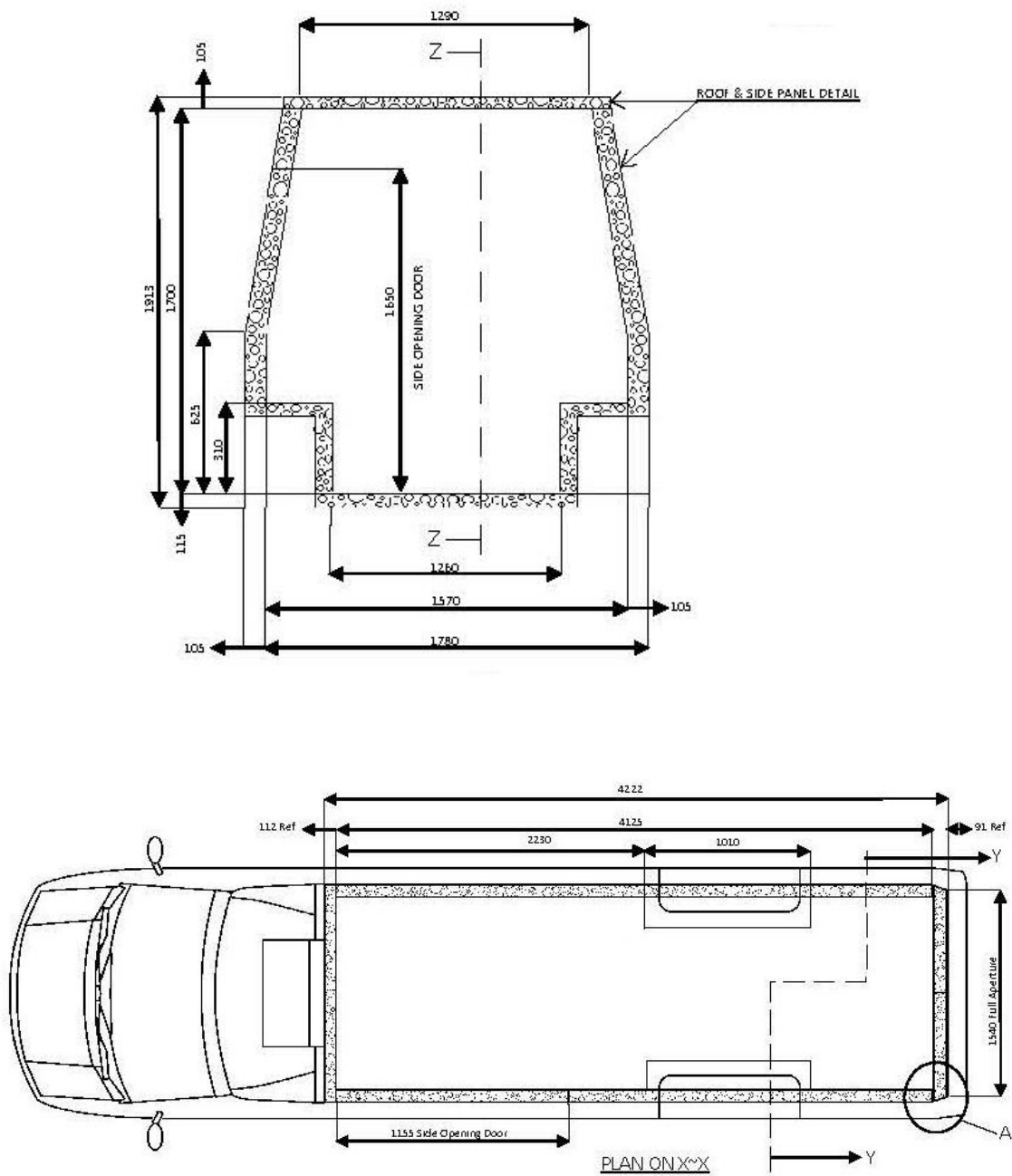

Method A

				Internal					External
Roof	4.125				Roof	4.222			
		1.29		5.32125			1.5		6.333
Floor	4.125				Floor	4.222			
		1.57		6.48			1.78		7.52
Sides	4.125				Sides	4.222			
		1.7		14.025			1.913		16.15337
Bulkhead	1.29				Bulkhead	1.5			
		1.70		1.72			1.91		2.55
Door	1.57				Door	1.78			
	1.29					1.5			
		1.7		1.72			1.913		2.55
	1.57					1.78			
				Si 29.27					Se 35.11
with wheel arches	0.1922			Si 29.46					Se 35.30

Method B (excluding wheel arches)

$WE = WI + \text{declared thicknesses}$

Wia	1.57
Wib	1.57
Wic	1.29
a	0.31
b	0.315
c	1.075
WI	1.481471
Declared Thickness	0.22
WE	1.701471

$LI = \frac{(LI_a \times a) + (LI_b + LI_c) / 2 \times b + (LI_c \times c)}{a + b + c}$

$LE = LI + \text{mean declared thicknesses}$

Lia	4.125
Lib	4.125
Lic	4.125
a	0.31
b	0.315
c	1.075
LI	4.125
Declared Thickness	0.203
LE	4.328

$Wi = Wi \text{ back} + Wi \text{ front}$

Wiback	1.57
Wifront	1.57
Wi	1.57
Declared Thickness	0.21
We	1.78



Temperature measuring points

1.3 In the case of parallelepipedic bodies, the mean inside temperature of the body (T_i) is the arithmetic mean of the temperatures measured 10 cm from the walls at the following 12 points:

- (a) The eight inside corners of the body; and
- (b) The centres of the four inside faces having the largest area.

If the body is not parallelepipedic, the 12 points of measurements shall be distributed as satisfactorily as possible having regard to the shape of the body.

1.4 In the case of parallelepipedic bodies, the mean outside temperature of the body (T_e) is the arithmetic mean of the temperatures measured 10 cm from the walls at the following 12 points:

- (a) The eight outside corners of the body; and
- (b) The centres of the four outside faces having the largest area.

If the body is not parallelepipedic, the 12 points of measurement shall be distributed as satisfactorily as possible having regard to the shape of the body.

1.5 The mean temperature of the walls of the body is the arithmetic mean of the mean outside temperature of the body and the mean inside temperature of the body:

$$\frac{T_e + T_i}{2}$$

1.6 Temperature measuring instruments protected against radiation shall be placed inside and outside the body at the points specified in paragraphs 1.3 and 1.4 of this appendix.

Steady state period and duration of test

- 1.7 The mean outside temperatures and the mean inside temperatures of the body, taken over a steady period of not less than 12 hours, shall not vary by more than ± 0.3 K, and these temperatures shall not vary by more than ± 1.0 K during the preceding 6 hours.

The difference between the heating power or cooling capacity measured over two periods of not less than 3 hours at the start and at the end of the steady state period, and separated by at least 6 hours, shall be less than 3 %.

The mean values of the temperatures and heating or cooling capacity over at least the last 6 hours of the steady state period will be used in K coefficient calculation.

The mean inside and outside temperatures at the beginning and the end of the calculation period of at least 6 hours shall not differ by more than 0.2 K.

2. INSULATING CAPACITY OF EQUIPMENT

Procedures for measuring the K coefficient

2.1 Equipment other than liquid-foodstuffs tanks

- 2.1.1 The K coefficient shall be measured in continuous operation either by the internal cooling method or by the internal heating method. In either case, the empty body shall be placed in an insulated chamber.

Test method

- 2.1.2 Where the internal cooling method is used, one or more heat exchangers shall be placed inside the body. The surface area of these exchangers shall be such that, if a fluid at a temperature not lower than 0 °C⁶ passes through them, the mean inside temperature of the body remains below + 10 °C when continuous operation has been established. Where the internal heating method is used, electrical heating appliances (resistors, etc.) shall be used. The heat exchangers or electrical heating appliances shall be fitted with fans having a delivery rate sufficient to obtain 40 to 70 air charges per hour related to the empty volume of the tested body, and the air distribution around all inside surfaces of the tested body shall be sufficient to ensure that the maximum difference between the temperatures of any 2 of the 12 points specified in paragraph 1.3 of this appendix does not exceed 2 K when continuous operation has been established.

- 2.1.3 Heat quantity: The heat dissipated by the electrical resistance fan heaters shall not exceed a flow of 1W/cm² and the heater units shall be protected by a casing of low emissivity.

The electrical energy consumption shall be determined with an accuracy of $\pm 0.5\%$.

⁶ To prevent frosting.

Test procedure

- 2.1.4 Whatever the method employed, the mean temperature of the insulated chamber shall throughout the test be kept uniform, and constant in compliance with paragraph 1.7 of this appendix, to within ± 0.5 K, at a level such that the temperature difference between the inside of the body and the insulated chamber is $25\text{ }^{\circ}\text{C} \pm 2$ K, the average temperature of the walls of the body being maintained at $+ 20\text{ }^{\circ}\text{C} \pm 0.5$ K.
- 2.1.5 During the test, whether by the internal cooling method or by the internal heating method, the mass of air in the chamber shall be made to circulate continuously so that the speed of movement of the air 10 cm from the walls is maintained at between 1 and 2 metres/second.
- 2.1.6 The appliances for generating and distributing cold or heat and for measuring the quantity of cold or heat exchanged and the heat equivalent of the air-circulating fans shall be started up. Electrical cable losses between the heat input measuring instrument and the tested body shall be established by a measurement or calculation and subtracted from the total heat input measured.
- 2.1.7 When continuous operation has been established, the maximum difference between the temperatures at the warmest and at the coldest points on the outside of the body shall not exceed 2 K.
- 2.1.8 The mean outside temperature and the mean inside temperature of the body shall each be read not less than four times per hour.

2.2 Liquid-foodstuffs tanks

- 2.2.1 The method described below applies only to single-compartment or multiple-compartment tank equipment intended solely for the carriage of liquid foodstuffs such as milk. Each compartment of such tanks shall have at least one manhole and one discharge-pipe connecting socket; where there are several compartments they shall be separated from one another by non-insulated vertical partitions.
- 2.2.2 K coefficients shall be measured in continuous operation by internal heating of the empty tank in an insulated chamber.

Test method

- 2.2.3 An electrical heating appliance (resistors, etc.) shall be placed inside the tank. If the tank has several compartments, an electrical heating appliance shall be placed in each compartment. The electrical heating appliances shall be fitted with fans with a delivery rate sufficient to ensure that the difference between the maximum temperature and the minimum temperature inside each compartment does not exceed 3 K when continuous operation has been established. If the tank comprises several compartments, the difference between the mean temperature in the coldest compartment and the mean temperature in the warmest compartment shall not exceed 2 K, the temperatures being measured as specified in paragraph 2.2.4 of this appendix.
- 2.2.4 Temperature measuring instruments protected against radiation shall be placed inside and outside the tank 10 cm from the walls, as follows:
- (a) If the tank has only one compartment, measurements shall be made at a minimum of 12 points positioned as follows:

The four extremities of two diameters at right angles to one another, one horizontal and the other vertical, near each of the two ends of the tank;

The four extremities of two diameters at right angles to one another, inclined at an angle of 45° to the horizontal, in the axial plane of the tank;

Comment to paragraph 2.2.4 (a):

The layout of the placement of air temperature measuring devices inside and outside tanks with one compartment is shown in figure 1 in the section on ATP Examples of Good Practice at the end of this publication. (ECE/TRANS/WP.11/220, para. 40)

- (b) If the tank has two compartments, the measurements shall be made at least at the following points:

Near the end of the first compartment and near the partition with the second compartment, at the extremities of three radiuses forming 120° angles, one of the radiuses being directed vertically upwards.

Near the end of the second compartment and near the partition with the first compartment, at the extremities of three radiuses forming 120° angles, one of the radiuses being directed vertically downwards.

Comment to paragraph 2.2.4 (b):

The layout of the placement of air temperature measurement devices inside and outside tanks with two compartments is shown in figure 2. (ECE/TRANS/WP.11/222, para. 35)

- (c) If the tank has several compartments, the points of measurement shall be as follows:

for each of the two end compartments, at least the following:

The extremities of a horizontal diameter near the end and the extremities of a vertical diameter near the partition;

and for each of the other compartments, at least the following:

The extremities of a diameter inclined at an angle of 45° to the horizontal near one of the partitions and the extremities of a diameter perpendicular to the first and near the other partition.

- (d) The mean inside temperature and the mean outside temperature of the tank shall respectively be the arithmetic mean of all the measurements taken inside and all the measurements taken outside the tank. In the case of tanks having at least two compartments, the mean inside temperature of each compartment shall be the arithmetic mean of the measurements made in the compartment, and the number of those measurements in each compartment shall be no less than four and the total number of measurements in all compartments of the tank shall be no less than twelve.

Comment to paragraph 2.2.4 (c):

The layout of the placement of air temperature measuring devices inside and outside tanks with three or more compartments is shown in figure 3 in the section on ATP Examples of Good Practice at the end of this publication. (ECE/TRANS/WP.11/220, para. 40)

Test procedure

- 2.2.5 Throughout the test, the mean temperature of the insulated chamber shall be kept uniform, and constant in compliance with paragraph 1.7 of this appendix, at a level such that the difference in temperature between the inside of the tank and that of the insulated chamber is not less than 25 °C ± 2 K, with the average temperature of the tank walls being maintained at + 20 °C ± 0.5 K.
- 2.2.6 The mass of air in the chamber shall be made to circulate continuously so that the speed of movement of the air 10 cm from the walls is maintained at between 1 and 2 metres/second.

- 2.2.7 The appliances for heating and circulating the air and for measuring the quantity of heat exchanged and the heat equivalent of the air-circulating fans shall be started up.
- 2.2.8 When continuous operation has been established, the maximum difference between the temperatures at the warmest and at the coldest points on the outside of the tank shall not exceed 2 K.
- 2.2.9 The mean outside temperature and the mean inside temperature of the tank shall each be read not less than four times per hour.

2.3 Provisions common to all types of insulated equipment

2.3.1 Verification of the K coefficient

Where the purpose of the tests is not to determine the K coefficient but simply to verify that it is below a certain limit, the tests carried out as described in paragraphs 2.1.1 to 2.2.9 of this appendix may be stopped as soon as the measurements made show that the K coefficient meets the requirements.

2.3.2 Accuracy of measurements of the K coefficient

Testing stations shall be provided with the equipment and instruments necessary to ensure that the K coefficient is determined with a maximum margin of error of $\pm 10\%$ when using the method of internal cooling and $\pm 5\%$ when using the method of internal heating.

Comments to paragraph 2.3:

1. *Examples for the errors which are normally taken into account by the test stations are temperature, power and the surface area of the body.*

The method of calculating the error, which is usually applied, is the total admissible error ε :

$$\varepsilon = \sqrt{\left(\frac{\Delta S}{S}\right)^2 + \left(\frac{\Delta W}{W}\right)^2 + \left(2 \frac{\Delta T}{T_e - T_i}\right)}$$

or the absolute error e_m :

$$e_m = \frac{\Delta S}{S} + \frac{\Delta W}{W} + 2 \cdot \frac{\Delta T}{T_e - T_i}$$

where:

S is the mean surface area of the vehicle body (geometric mean of the internal and external surfaces);

W is the power dissipated inside the vehicle body in the steady state T_e and T_i are in the respective external and internal temperatures of the vehicle body under test.

2. *Under normal test conditions, S can be measured to 1%. However, there are cases where it is impossible to measure with this precision.*

The error of W does not exceed 1%, although certain test stations use equipment giving a greater error.

Temperature is measured with an absolute accuracy of $\square 0.1$ K. The measurement of a temperature difference ($T_e - T_i$) of the order of 20 K therefore gives an error of twice 0,5%, i.e. 1%.

The total error is therefore $\varepsilon = \pm \sqrt{0.0003} = 0.017$ i.e. 1.7 %. The maximum admissible error is $e_m = 3\%$.

3. Other errors which have not been taken into consideration can have an effect on the exact value of the K coefficient. These errors are as follows:

- (a) Latent errors due to admissible variations in the internal and external temperatures, which are a function of the thermal inertia of the walls of the equipment, the temperature and time;
- (b) Errors due to the variation of air velocity at the boundary layer and its effect on the thermal resistance.

If the internal and external air velocities are of equal value, the possible error will be about 2.5 % as between 1 to 2 m/s for a mean K coefficient of 0.40 W/m².K. For a K coefficient of 0.70 W/m².K, this error will be nearly 5%. If there are significant thermal bridges, the influence of the speed and direction of the air will be greater.

4. Finally, because of the error in the estimation of the surface area of the body, an error which in practice is difficult to calculate when dealing with non standard equipment, (this estimation involving factors of a subjective nature), one could envisage the determination of the error in the measurement of the overall heat transfer per degree temperature difference:

$$\frac{W}{T_e - T_i} = K.S$$

Comments to paragraph 2.3.2:

1. Examples for the errors which are normally taken into account by the test stations are temperature, heat output, which is generally dependent on the electrical power consumed by the electric heating units (for the method of internal heating) or cold production (for the method of internal cooling) and the surface area of the body.

The relative margin of error for determining the K coefficient, ε_K , can be obtained by the relationship between the absolute margin of error for determining the K coefficient, ΔK , and its calculated (average) value, \bar{K} . As it is generally very complicated to establish the value for ΔK , it is advisable to use probability and mathematical statistic theory methods, determining the value of the confidence interval (of the random error) for \bar{K} , $\Delta_{\bar{K}}$, with a confidence probability (reliability) greater than 95%. In this case:

$$\varepsilon_K = \frac{\Delta K}{\bar{K}} \cdot 100 \cong \frac{\Delta_{\bar{K}}}{\bar{K}} \cdot 100$$

$$\Delta_{\bar{K}} = \sqrt{\left(\frac{\Delta_{\bar{W}}}{\bar{S} \cdot (\bar{T}_e - \bar{T}_i)}\right)^2 + \left(\frac{\bar{W} \cdot \Delta_{\bar{T}_i}}{\bar{S} \cdot (\bar{T}_e - \bar{T}_i)^2}\right)^2 + \left(\frac{\bar{W} \cdot \Delta_{\bar{T}_e}}{\bar{S} \cdot (\bar{T}_e - \bar{T}_i)^2}\right)^2 + \left(\frac{\bar{W} \cdot \Delta_{\bar{S}}}{\bar{S}^2 \cdot (\bar{T}_e - \bar{T}_i)}\right)^2}$$

where:

\bar{W} , \bar{T}_e , \bar{T}_i , \bar{S} — are sample mean values respectively for the heat output (or cold production), in W; the external and internal temperatures of the body, in °C; and the area of the average surface of the body, in m²;

$\Delta_{\bar{W}}$, $\Delta_{\bar{T}_i}$, $\Delta_{\bar{T}_e}$, $\Delta_{\bar{S}}$ — are the confidence intervals (random errors) respectively for the heat output (or cold production), in W; the external and internal temperatures of the body, in °C; and the area of the average surface of the body, in m².

$$\bar{W} = \frac{\sum_{k=1}^n W_k}{n}$$

$$W_k = \eta_k \cdot Q_k$$

$$\Delta_{\bar{W}} = \sqrt{\left(t_{\alpha, n} \cdot \sqrt{\frac{\sum_{k=1}^n (\bar{W} - W_k)^2}{n \cdot (n-1)}} \right)^2 + (\alpha \cdot \Delta_Q)^2}$$

$$\bar{T}_i = \frac{\sum_{k=1}^n \sum_{i=1}^l T_{i,k}}{n \cdot l}$$

$$\Delta_{\bar{T}_i} = \sqrt{\left(t_{\alpha, (n \cdot l)} \cdot \sqrt{\frac{\sum_{k=1}^n \sum_{i=1}^l (\bar{T}_i - T_{i,k})^2}{(n \cdot l) \cdot (n \cdot l - 1)}} \right)^2 + (\alpha \cdot \Delta_{T_i})^2}$$

$$\bar{T}_e = \frac{\sum_{k=1}^n \sum_{j=1}^m T_{e,j,k}}{n \cdot m}$$

$$\Delta_{\bar{T}_e} = \sqrt{\left(t_{\alpha, (n \cdot m)} \cdot \sqrt{\frac{\sum_{k=1}^n \sum_{j=1}^m (\bar{T}_e - T_{e,j,k})^2}{(n \cdot m) \cdot (n \cdot m - 1)}} \right)^2 + (\alpha \cdot \Delta_{T_e})^2}$$

$$\Delta_{\bar{S}} = \sqrt{\frac{(\bar{S}_i \cdot \Delta_{\bar{S}_e})^2 + (\bar{S}_e \cdot \Delta_{\bar{S}_i})^2}{4 \cdot \bar{S}_e \cdot \bar{S}_i}}$$

where:

Q_k, W_k — are the measured values respectively of the electrical power consumed from the grid and the heat output (or cold production), when measuring the k th measurement (overall, for the calculation period, at the end of the steady state period, n measurements taken), in W;

η_k — is the coefficient of efficiency of electrical heating devices, taking into account losses in wiring (for the method of internal heating) or of heat exchangers (for the method of internal cooling), when measuring the k th measurement, expressed as a fraction;

$T_{i,k}, T_{e,j,k}$ — are the temperatures measured at the k th measurement, respectively using the i -instrument inside the body of the special equipment under test (in all, with one measurement, simultaneously taken by l uniformly precise thermometers) and by instrument j on the outside of the body of the special equipment under test (in all, with one measurement, simultaneously taken by m uniformly precise thermometers), in °C;

$\Delta_{\bar{T}_i}, \Delta_{T_e}, \Delta_Q$ — are the instrument margins of error for the measurement of temperatures respectively inside and outside the body of the special equipment under test, in K, and the electrical power consumed from the grid, in W;

$t_{\alpha, n}, t_{\alpha, (n \cdot l)}, t_{\alpha, (n \cdot m)}$ — are the values of the Student's t -coefficient for a given confidence level $\alpha (\alpha \geq 0.95)$ and the corresponding quantity of measurements taken of physical magnitudes;

\bar{S}_i, \bar{S}_e — are the sample mean areas respectively of the inner and outer surfaces of the body of the special equipment under test (disregarding corrugation), in m^2 ;

$\Delta_{\bar{S}_i}$, $\Delta_{\bar{S}_e}$ — are the confidence intervals (random errors) of the area of the body surface respectively of the inner and outer surfaces of the special equipment under test, in m^2 .

Using the method of internal heating, η_k can be calculated based on the assumption that the electrical power in the electric heating units is transformed into heat with practically no loss. In such a case the only loss will be in the wiring, calculated as follows:

$$\eta_k = 1 - \frac{2 \cdot Q_k \cdot L_{line} \cdot \rho}{U^2 \cdot s}$$

where:

Q_k — is the value of the electric power consumed from the grid measured at the k th measurement, in W;

L_{line} — is the length of the power cable from the meter to the location of the corresponding device, in m;

ρ — is the resistivity of the wire in the power cable, in ohm·mm²/m;

U — is the rated electric tension in the grid, in V;

s — is the cross-sectional area of the wire in the power cable, in mm².

When using the method of internal cooling, the calculation of η_k must take into account the specific means of cooling employed and the equipment used.

Instrument margins of error may be indicated by the manufacturer of the measurement equipment as absolute values, in which case they shall be used directly in the calculation formulae or as an accuracy class. In the latter case, the margin of error may be standardized in relation to the result of the measurement:

$$\Delta_x = \frac{\delta}{100} \cdot x$$

or may be expressed thus:

$$\Delta_x = \frac{\delta}{100} \cdot X$$

where:

δ — is the value of the accuracy class indicated by the manufacturer of the measurement instrument, in %;

x — is the value of the measured physical phenomenon. If it is determined in a series of measurements as an average of the results, it is advisable to use the maximum value in the series of measurements for the calculated value of x ;

X — is the maximum admissible value for the measured physical phenomenon x in a given operating range of the measurement instrument.

2. Under normal test conditions, \bar{S}_i and \bar{S}_e can be measured with a high degree of accuracy. Generally, the following method may be used to determine the margins of error of \bar{S}_i and \bar{S}_e , which are used to determine the average surface area of the body, \bar{S} .

If \bar{S}_i and \bar{S}_e are presented as functions of a series of repeated measurements, \bar{p}_i and \bar{p}_e , (for example, the length, width and height measured at various places in the body of the special equipment):

$$\bar{S}_i = f_1(\bar{p}_{i1}, \bar{p}_{i2}, \dots, \bar{p}_{iY})$$

$$\bar{S}_e = f_2(\bar{p}_{e1}, \bar{p}_{e2}, \dots, \bar{p}_{eZ})$$

then:

$$\Delta_{\bar{S}_i} = \sqrt{\sum_{y=1}^Y \left(\Delta_{\bar{p}_{i_y}} \cdot \frac{\partial f_1}{\partial \bar{p}_{i_y}} \right)^2}$$

$$\Delta_{\bar{S}_e} = \sqrt{\sum_{z=1}^Z \left(\Delta_{\bar{p}_{e_z}} \cdot \frac{\partial f_2}{\partial \bar{p}_{e_z}} \right)^2}$$

where:

$\frac{\partial f_1}{\partial \bar{p}_{i_y}}, \frac{\partial f_2}{\partial \bar{p}_{e_z}}$ — are respectively the partial derivatives for the functions to calculate \bar{S}_i and \bar{S}_e ;

$\Delta_{\bar{p}_{i_y}}, \Delta_{\bar{p}_{e_z}}$ — are respectively the confidence intervals for the parameters \bar{p}_{i_y} and \bar{p}_{e_z} .

$$\bar{p}_{i_y} = \frac{\sum_{v=1}^V p_{i_{y_v}}}{V}$$

$$\Delta_{\bar{p}_{i_y}} = \sqrt{\left(t_{\alpha, V} \cdot \sqrt{\frac{\sum_{v=1}^V (\bar{p}_{i_y} - p_{i_{y_v}})^2}{V \cdot (V - 1)}} \right)^2 + (\alpha \cdot \Delta_{p_{i_y}})^2}$$

where:

V — is the quantity of measurements carried out to determine the average value of parameter p_{i_y} ;

$p_{i_{y_v}}$ — is the measured value of parameter p_{i_y} at the v th measurement;

$t_{\alpha, V}$ — is the value of the Student's t -coefficient for a given confidence level α ($\alpha \geq 0.95$) and the corresponding quantity of measurements of parameter p_{i_y} , V ;

$\Delta_{p_{i_y}}$ — is the instrument margin of error for the parameter p_{i_y} ;

\bar{p}_{e_z} and $\Delta_{\bar{p}_{e_z}}$ are determined in the same way as \bar{p}_{i_y} and $\Delta_{\bar{p}_{i_y}}$.

The values of parameters \bar{p}_{i_y} and \bar{p}_{e_z} can be taken as given (in the technical documentation of the special equipment). In this case:

$$\Delta_{\bar{p}_{i_y}} = \alpha \cdot d_{p_{i_y}}$$

$$\Delta_{\bar{p}_{e_z}} = \alpha \cdot d_{p_{e_z}}$$

where:

$d_{p_{i_y}}, d_{p_{e_z}}$ — are the unit in the highest digit position of the parameter in question, divided by two;

3. Other errors which have not been taken into consideration can have an effect on the exact value of the K coefficient. These errors are as follows:

(a) Latent errors due to admissible variations in the internal and external temperatures, which are a function of the thermal inertia of the walls of the equipment, the temperature and time;

(b) Errors due to the variation of air velocity at the boundary layer and its effect on the thermal resistance.

If the internal and external air velocities are of equal value, the possible error will be about 2.5% as between 1 to 2 m/s for a mean K coefficient of 0.40 W/m².K. For a K coefficient of 0.70 W/m².K, this error will be nearly 5%. If there are significant thermal bridges, the influence of the speed and direction of the air will be greater.

3. EFFECTIVENESS OF THERMAL APPLIANCES OF EQUIPMENT

Procedures for determining the efficiency of thermal appliances of equipment

3.1 Refrigerated equipment

3.1.1 The empty equipment shall be placed in an insulated chamber whose mean temperature shall be kept uniform, and constant to within ± 0.5 K, at + 30 °C. The mass of air in the chamber shall be made to circulate as described in paragraph 2.1.5 of this appendix.

3.1.2 Temperature measuring instruments protected against radiation shall be placed inside and outside the body at the points specified in paragraphs 1.3 and 1.4 of this appendix.

Test procedure

3.1.3 (a) In the case of **equipment other than equipment with fixed eutectic plates, and equipment fitted with liquefied gas systems**, the maximum weight of refrigerant specified by the manufacturer or which can normally be accommodated shall be loaded into the spaces provided when the mean inside temperature of the body has reached the mean outside temperature of the body (+ 30 °C). Doors, hatches and other openings shall be closed and the inside ventilation appliances (if any) of the equipment shall be started up at maximum capacity. In addition, in the case of new equipment, a heating appliance with a heating capacity equal to 35% of the heat exchanged through the walls in continuous operation shall be started up inside the body when the temperature prescribed for the class to which the equipment is presumed to belong has been reached. No additional refrigerant shall be loaded during the test;

(b) In the case of **equipment with fixed eutectic plates**, the test shall comprise a preliminary phase of freezing of the eutectic solution. For this purpose, when the mean inside temperature of the body and the temperature of the plates have reached the mean outside temperature (+ 30 °C), the plate-cooling appliance shall be put into operation for 18 consecutive hours after closure of the doors and hatches. If the plate-cooling appliance includes a cyclically-operating mechanism, the total duration of operation of the appliance shall be 24 hours. In the case of new equipment, as soon as the cooling appliance is stopped, a heating appliance with a heating capacity equal to 35% of the heat exchanged through the walls in continuous operation shall be started up inside the body when the temperature prescribed for the class to which the equipment is presumed to belong has been reached. The solution shall not be subjected to any re-freezing operation during the test;

(c) In the case of **equipment fitted with liquefied gas systems**, the following test procedure shall be used: when the mean inside temperature of the body has reached the mean outside temperature (+ 30 °C), the receptacles for the liquefied gas shall be filled to the level prescribed by the manufacturer. Then the doors, hatches and other openings shall be closed as in normal operation and the inside ventilation appliances (if any) of the equipment shall be started up at maximum capacity. The thermostat shall be set at a temperature not more than 2 degrees below the limit temperature of the presumed class of the equipment. Cooling of the body then shall be commenced. During the cooling of the body the refrigerant consumed is simultaneously replaced. This replacement shall be effected:

either for a time corresponding to the interval between the commencement of cooling and the moment when the temperature prescribed for the class to which the equipment is presumed to belong is reached for the first time; or

for a duration of three hours counting from the commencement of cooling, whichever is shorter.

Beyond this period, no additional refrigerant shall be loaded during the test.

In the case of new equipment, a heating appliance with a heating capacity equal to 35% of the heat exchanged through the walls in continuous operation shall be started up inside the body when the class temperature has been reached.

Provisions common to all types of refrigerated equipment

- 3.1.4 The mean outside temperature and the mean inside temperature of the body shall each be read not less often than once every 30 minutes.
- 3.1.5 The test shall be continued for 12 hours after the mean inside temperature of the body has reached the lower limit prescribed for the class to which the equipment is presumed to belong (A = +7 °C; B = -10 °C; C = -20 °C; D = 0 °C) or, in the case of equipment with fixed eutectic plates, after stoppage of the cooling appliance.

Criterion of satisfaction

- 3.1.6 The test shall be deemed satisfactory if the mean inside temperature of the body does not exceed the aforesaid lower limit during the aforesaid period of 12 hours.

3.2 Mechanically refrigerated equipment

Test method

- 3.2.1 The test shall be carried out in the conditions described in paragraphs 3.1.1 and 3.1.2 of this appendix.

Test procedure

- 3.2.2 When the mean inside temperature of the body reaches the outside temperature (+ 30 °C), the doors, hatches and other openings shall be closed and the refrigerating appliance and the inside ventilating appliances (if any) shall be started up at maximum capacity. In addition, in the case of new equipment, a heating appliance with a heating capacity equal to 35% of the heat exchanged through the walls in continuous operation shall be started up inside the body when the temperature prescribed for the class to which the equipment is presumed to belong has been reached.
- 3.2.3 The mean outside temperature and the mean inside temperature of the body shall each be read not less often than once every 30 minutes.
- 3.2.4 The test shall be continued for 12 hours after the mean inside temperature of the body has reached:
either the lower limit prescribed for the class to which the equipment is presumed to belong in the case of classes A, B and C (A = 0 °C; B = -10 °C; C = -20 °C); or
a level not lower than the upper limit prescribed for the class to which the equipment is presumed to belong in the case of classes D, E, and F (D = 0 °C; E = -10 °C; F = -20 °C).

Criterion of satisfaction

- 3.2.5 The test shall be deemed satisfactory if the refrigerating appliance is able to maintain the prescribed temperature conditions during the said 12-hour periods, with any automatic defrosting of the refrigerating unit not being taken into account.

- 3.2.6 If the refrigerating appliance with all its accessories has undergone separately, to the satisfaction of the competent authority, a test to determine its effective refrigerating capacity at the prescribed reference temperatures, the transport equipment may be accepted as mechanically refrigerated equipment without undergoing an efficiency test if the effective refrigerating capacity of the appliance in continuous operation exceeds the heat loss through the walls for the class under consideration, multiplied by the factor 1.75.

Comment to paragraph 3.2.6:

The proposed provision concerning the use of a multiplier factor of 1.75 when determining the refrigerating capacity of the appliance to be installed on a body, is to be applicable whether or not the body was fitted with an appliance when the K coefficient was measured. If during the insulation test the body was not equipped with an appliance, it would be advisable to ensure that the K coefficient of that body when equipped with an appliance does not exceed the class limits, in order to allow for the variations that might occur with equipment of differing lengths or types.

- 3.2.7 If the mechanically refrigerating unit is replaced by a unit of a different type, the competent authority may:
- (a) require the equipment to undergo the determinations and verifications prescribed in paragraphs 3.2.1 to 3.2.4; or
 - (b) satisfy itself that the effective refrigerating capacity of the new mechanically refrigerating unit is, at the temperature prescribed for equipment of the class concerned, at least equal to that of the unit replaced; or
 - (c) satisfy itself that the effective refrigerating capacity of the new mechanically refrigerating unit meets the requirements of paragraph 3.2.6.

3.3 Heated equipment

Test method

- 3.3.1 The empty equipment shall be placed in an insulated chamber whose temperature shall be kept uniform and constant at as low a level as possible. The atmosphere of the chamber shall be made to circulate as described in paragraph 2.1.5 of this appendix.
- 3.3.2 Temperature measuring instruments protected against radiation shall be placed inside and outside the body at the points specified in paragraphs 1.3 and 1.4 of this appendix.

Test procedure

- 3.3.3 Doors, hatches and other openings shall be closed and the heating equipment and the inside ventilating appliances (if any) shall be started up at maximum capacity.
- 3.3.4 The mean outside temperature and the mean inside temperature of the body shall each be read not less often than once every 30 minutes.
- 3.3.5 The test shall be continued for 12 hours after the difference between the mean inside temperature and the mean outside temperature of the body has reached the level corresponding to the conditions prescribed for the class to which the equipment is presumed to belong. In the case of new equipment, the above temperature difference shall be increased by 35 per cent.

Criterion of satisfaction

- 3.3.6 The test shall be deemed satisfactory if the heating appliance is able to maintain the prescribed temperature difference during the 12 hours aforesaid.

3.4 Mechanically refrigerated and heated equipment

Test method

- 3.4.1 The test shall be carried out in two stages. The efficiency of the refrigeration unit of the refrigerating or refrigerating-heating appliance is determined in the first stage and that of the heating appliance is determined in the second stage.
- 3.4.2 In the first stage, the test shall be carried out in the conditions described in paragraphs 3.1.1 and 3.1.2 of this appendix; in the second stage, it shall be carried out in the conditions described in paragraphs 3.3.1 and 3.3.2 of this appendix.

Test procedure

- 3.4.3 The basic requirements for the test procedure for the first stage are described in paragraphs 3.2.2 and 3.2.3 of this appendix; those for the second stage are described in paragraphs 3.3.3 and 3.3.4 of this appendix.
- 3.4.4 The second stage of the test may be initiated immediately after the end of the first stage, without the measuring equipment being dismantled.
- 3.4.5 In each stage, the test shall be continued for 12 hours after:
- (a) in the first stage, the mean inside temperature of the body has reached the lower limit prescribed for the class to which the equipment is presumed to belong;
 - (b) in the second stage, the difference between the mean inside temperature of the body and the mean outside temperature of the body has reached the level corresponding to the conditions prescribed for the class to which the equipment is presumed to belong. In the case of new equipment, the above temperature difference shall be increased by 35 per cent.

Criterion of satisfaction

- 3.4.6 The results of the test shall be deemed satisfactory if:
- (a) in the first stage, the refrigerating or refrigerating-heating appliance is able to maintain the prescribed temperature conditions during the said 12-hour period, with any automatic defrosting of the refrigerating or refrigerating-heating unit not being taken into account;
 - (b) in the second stage, the heating appliance is able to maintain the prescribed temperature difference during the said 12-hour period.
- 3.4.7 If the refrigerating unit of the refrigerating or refrigerating-heating appliance with all its accessories has undergone separately, to the satisfaction of the competent authority, a test to determine its effective refrigerating capacity at the prescribed reference temperatures, the transport equipment may be accepted as having passed the first stage of the test without undergoing an efficiency test if the effective refrigerating capacity of the appliance in continuous operation exceeds the heat loss through the walls for the class under consideration, multiplied by the factor 1.75.
- 3.4.8 If the mechanically refrigerating unit of the refrigerating or refrigerating-heating appliance is replaced by a unit of a different type, the competent authority may:
- (a) require the equipment to undergo the determinations and verifications for the first stage of testing prescribed in paragraphs 3.4.1–3.4.5 of this appendix; or
 - (b) satisfy itself that the effective refrigerating capacity of the new mechanically refrigerating unit is, at the temperature prescribed for equipment of the class concerned, at least equal to

that of the unit replaced; or

- (c) satisfy itself that the effective refrigerating capacity of the new mechanically refrigerating unit meets the requirements of paragraph 3.4.7 of this appendix.

4. PROCEDURE FOR MEASURING THE EFFECTIVE REFRIGERATING CAPACITY W_o OF A UNIT WHEN THE EVAPORATOR IS FREE FROM FROST

4.1 General principles

- 4.1.1 When attached to either a calorimeter box or the insulated body of a unit of transport equipment, and operating continuously, this capacity is:

$$W_o = W_j + U \cdot \Delta T$$

where U is the heat leakage of the calorimeter box or insulated body, Watts/°C.

ΔT is the difference between the mean inside temperature T_i and the mean outside temperature T_e of the calorimeter or insulated body (K),

W_j is the heat dissipated by the fan heater unit to maintain each temperature difference in equilibrium.

4.2 Test method

- 4.2.1 The refrigeration unit is either fitted to a calorimeter box or the insulated body of a unit of transport equipment.

In each case, the heat leakage is measured at a single mean wall temperature prior to the capacity test. An arithmetical correction factor, based upon the experience of the testing station, is made to take into account the average temperature of the walls at each thermal equilibrium during the determination of the effective refrigerating capacity.

It is preferable to use a calibrated calorimeter box to obtain maximum accuracy.

Measurements and procedure shall be as described in paragraphs 1.1 to 2.1.8 above; however, it is sufficient to measure U the heat leakage only, the value of this coefficient being defined by the following relationship:

$$U = \frac{W}{\Delta T_m}$$

where:

W is the heating power (in Watts) dissipated by the internal heater and fans;

ΔT_m is the difference between the mean internal temperature T_i and the mean external temperature T_e ;

U is the heat flow per degree of difference between the air temperature inside and outside the calorimeter box or unit of transport equipment measured with the refrigeration unit fitted.

The calorimeter box or unit of transport equipment is placed in a test chamber. If a calorimeter box is used, $U \cdot \Delta T$ should be not more than 35% of the total heat flow W_o .

The calorimeter box or unit of transport equipment shall be heavily insulated.

[Comment to paragraph 4.2.1:](#)

The U factor of a calorimeter box is usually measured without the refrigeration unit fitted to the aperture. In the case of a unit of transport equipment, measurement of U may be made with or without the refrigeration unit fitted to the insulated body, in the absence of a refrigeration unit an insulated panel is fitted to the aperture.

4.2.2 Instrumentation

Test stations shall be equipped with instruments to measure the U value to an accuracy of $\pm 5\%$. Heat transfer through air leakage should not exceed 5% of the total heat transfer through the calorimeter box or through the insulated body of the unit of transport equipment. The refrigerating capacity shall be determined with an accuracy of $\pm 5\%$.

The instrumentation of the calorimeter box or unit of transport equipment shall conform to paragraphs 1.3 and 1.4 above. The following are to be measured:

- (a) *Air temperatures:* At least four thermometers uniformly distributed at the inlet to the evaporator;

At least four thermometers uniformly distributed at the outlet to the evaporator;

At least four thermometers uniformly distributed at the air inlet(s) to the refrigeration unit;

The thermometers shall be protected against radiation.

The accuracy of the temperature measuring system shall be ± 0.2 K;

- (b) *Energy consumption:* Instruments shall be provided to measure the electrical energy or fuel consumption of the refrigeration unit.

The electrical energy and fuel consumption shall be determined with an accuracy of $\pm 0.5\%$;

Comment to paragraph 4.2.2 (b):

1. *This procedure describes the measurement method for determining the fuel consumption of vehicle powered refrigeration units, or in other words the increase in diesel engine fuel consumption when the refrigeration unit is on.*

2. *Three standards have been introduced and used to determine the increase in fuel consumption as a result of the operation of the refrigeration unit:*

- *Standard diesel engine with standard specific fuel consumption: $c_s = 165$ g/(kW. h).*
- *Standard vehicle alternator efficiency: $\epsilon = 50$ %.*
- *Standard diesel fuel specific density: $\rho = 836$ g/l.*

3. *The most frequent arrangement is assumed: the refrigeration compressor or a special electric generator supplying the refrigeration unit is driven from the vehicle engine crankshaft (usually by a belt drive). Using a suitable design of power pack in the test station, the torque τ [N.m] and operating rotational speed n [s^{-1}] are measured and the input power P_1 [W] on the shaft of the compressor or generator is calculated.*

$$P_1 \text{ [W]} = 2\pi n \tau \quad \dots \text{ where } \pi = 3.141593$$

4. *There are also vehicle-powered units taking in addition electric current from the standard (or auxiliary) vehicle alternator, or from vehicle batteries, usually to drive electric fans and blowers. Regarding the shaft power P_2 [W] of a standard or auxiliary alternator determined from electric*

measurement, the efficiency of such vehicle alternators has to be considered (usually 24 V dc, 100 A to 150 A). Alternator efficiency ϵ for these calculations is postulated at 50 % (see the second of the three standards mentioned above). Accordingly, if P_{fans} is the total electric input needed to drive the fans, the alternator shaft input is:

$$P_2 = 2 \times P_{fans}$$

5. In this case the total input power P [W] that the vehicle engine has to deliver to the refrigeration unit consists of the compressor input P_1 and of the alternator input P_2 for the fans:

$$P = P_1 + P_2$$

6. If P [W] is the total refrigeration unit input power at specific operating conditions, then the fuel consumption by weight C_{fw} [g/h] of the tested refrigeration unit can be calculated as:

$$C_{fw} \text{ [g/h]} = P \times c_s = 0.165 \times P.$$

7. The consumption by weight (measured in g/h) can be converted to consumption by volume (measured in l/h) if the specific density ρ of the diesel fuel is known. This density varies from 830 kg/m³ (winter) to 842 kg/m³ (summer). The standard (mean) value of the specific density $\rho = 836 \text{ kg/m}^3 = 836 \text{ g/l}$ has been used for the purposes of this procedure (see the third of the standards mentioned above).

$$C_{fvol} \text{ [l/h]} = C_{fw} / 836$$

8. It is beneficial to introduce specific fuel consumption; it is the quantity which can be used to compare the economy of units with different refrigeration capacities. Specific fuel consumption $cfvol$ (consumption by volume reduced to 1 kW of refrigeration capacity Q) is defined in this way:

$$cfvol \text{ [l/(h.kW)]} = 1000 C_{fvol} / Q$$

- (c) *Speed of rotation:* Instruments shall be provided to measure the speed of rotation of the compressors and circulating fans or to allow these speeds to be calculated where direct measurement is impractical.

The speed of rotation shall be measured to an accuracy of $\pm 1\%$;

- (d) *Pressure:* High precision pressure gauges (accurate to $\pm 1\%$) shall be fitted to the condenser and evaporator and to the compressor inlet when the evaporator is fitted with a pressure regulator.

4.2.3 Test conditions

- (i) The average air temperature at the inlet(s) to the refrigeration unit shall be maintained at $30 \text{ }^\circ\text{C} \pm 0.5 \text{ K}$.

The maximum difference between the temperatures at the warmest and at the coldest points shall not exceed 2 K.

- (ii) Inside the calorimeter box or the insulated body of the unit of transport equipment (at the air inlet to the evaporator): there shall be three levels of temperature between $-25 \text{ }^\circ\text{C}$ and $+12 \text{ }^\circ\text{C}$ depending on the characteristics of the unit, one temperature level being at the minimum prescribed for the class requested by the manufacturer with a tolerance of $\pm 1 \text{ K}$.

The mean inside temperature shall be maintained within a tolerance of $\pm 0.5 \text{ K}$. During the measurement of refrigerating capacity, the heat dissipated within the calorimeter box or the

insulated body of the unit of transport equipment shall be maintained at a constant level with a tolerance of $\pm 1\%$.

When presenting a refrigeration unit for test, the manufacturer shall supply:

- Documents describing the unit to be tested;
- A technical document outlining the parameters that are most important to the functioning of the unit and specifying their allowable range;
- The characteristics of the equipment series tested; and
- A statement as to which prime mover(s) shall be used during testing.

4.3 Test procedure

4.3.1 The test shall be divided into two major parts, the cooling phase and the measurement of the effective refrigerating capacity at three increasing temperature levels.

- (a) Cooling phase; the initial temperature of the calorimeter box or transport equipment shall be $30\text{ °C} \pm 3\text{ K}$. It shall then be lowered to the following temperatures: -25 °C for -20 °C class, -13 °C for -10 °C class or -2 °C for 0 °C class;
- (b) Measurement of effective refrigerating capacity, at each internal temperature level.

A first test to be carried out, for at least four hours at each level of temperature, under control of the thermostat (of the refrigeration unit) to stabilize the heat transfer between the interior and exterior of the calorimeter box or unit of transport equipment.

A second test shall be carried out without the thermostat in operation in order to determine the maximum refrigerating capacity, with the heating power of the internal heater producing an equilibrium condition at each temperature level as prescribed in paragraph 4.2.3.

The duration of the second test shall be not less than four hours.

Before changing from one temperature level to another, the box or unit shall be manually defrosted.

If the refrigeration unit can be operated by more than one form of energy, the tests shall be repeated accordingly.

If the compressor is driven by the vehicle engine, the test shall be carried out at both the minimum speed and at the nominal speed of rotation of the compressor as specified by the manufacturer.

If the compressor is driven by the vehicle motion, the test shall be carried out at the nominal speed of rotation of the compressor as specified by the manufacturer.

4.3.2 The same procedure shall be followed for the enthalpy method described below, but in this case the heat power dissipated by the evaporator fans at each temperature level shall also be measured.

This method may, alternatively, be used to test reference equipment. In this case, the effective refrigerating capacity is measured by multiplying the mass flow (m) of the refrigerant liquid by the difference in enthalpy between the refrigerant vapour leaving the unit (h_o) and the liquid at the inlet to the unit (h_i).

To obtain the effective refrigerating capacity, the heat generated by the evaporator fans (W_i) is

deducted. It is difficult to measure W_f if the evaporator fans are driven by an external motor, in this particular case the enthalpy method is not recommended. When the fans are driven by internal electric motors, the electrical power is measured by appropriate instruments with an accuracy of $\pm 3\%$, with refrigerant flow measurement being accurate to $\pm 3\%$.

The heat balance is given by the formula:

$$W_o = (h_o - h_i) m - W_f.$$

An electric heater is placed inside the equipment in order to obtain the thermal equilibrium.

4.3.3 Precautions

As the tests for effective refrigerating capacity are carried out with the thermostat of the refrigeration unit disconnected, the following precautions shall be observed:

If the equipment has a hot gas injection system, it shall be inoperative during the test;

with automatic controls of the refrigeration unit which unload individual cylinders (to tune the capacity of the refrigeration unit to motor output) the test shall be carried out with the number of cylinders appropriate for the temperature.

4.3.4 Checks

The following should be verified and the methods used indicated on the test report:

- (i) the defrosting system and the thermostat are functioning correctly;
- (ii) the rate of air circulation shall be measured using an existing standard;

If the air circulation of a refrigeration unit's evaporator fans is to be measured, methods capable of measuring the total delivery volume shall be used. Use of one of the relevant existing standards, i.e. ISO 5801: 2008, AMCA 210-99 and AMCA 210-07 is recommended;

- (iii) the refrigerant used for tests is that specified by the manufacturer.

4.4 **Test result**

- 4.4.1 The refrigeration capacity for ATP purposes is that relating to the mean temperature at the inlet(s) of the evaporator. The temperature measuring instruments shall be protected against radiation.

5. **CHECKING THE INSULATING CAPACITY OF EQUIPMENT IN SERVICE**

For the purpose of checking the insulating capacity of each piece of equipment in service as prescribed in appendix 1, paragraphs 1 (b) and 1 (c), to this annex, the competent authorities may:

Apply the methods described in paragraphs 2.1.1 to 2.3.2 of this appendix; or

Appoint experts to assess the fitness of the equipment for retention in one or other of the categories of insulated equipment. These experts shall take the following particulars into account and shall base their conclusions on information as indicated below.

5.1 **General examination of the equipment**

This examination shall take the form of an inspection of the equipment to determine the following:

- (i) the durable manufacturer's plate affixed by the manufacturer;

- (ii) the general design of the insulating sheathing;
- (iii) the method of application of insulation;
- (iv) the nature and condition of the walls;
- (v) the condition of the insulated compartment;
- (vi) the thickness of the walls;

and to make all appropriate observations concerning the effective insulating capacity of the equipment. For this purpose the experts may cause parts of the equipment to be dismantled and require all documents they may need to consult (plans, test reports, specifications, invoices, etc.) to be placed at their disposal.

Comment to paragraph 5.1:

Changes in the K-coefficient during the service life of insulated bodies depend on the following factors:

- (a) Nature of the insulating material;*
- (b) Nature of the covering layers (glass-fibre reinforced plastics or metal);*
- (c) Construction of the body;*
- (d) Number of doors and hatches permitted in the approval tests;*
- (e) Conditions of use (carriage of fresh produce or frozen or quick (deep) - frozen products).*

5.2 Examination for air-tightness (not applicable to tank equipment)

The inspection shall be made by an observer stationed inside the equipment, which shall be placed in a brightly-illuminated area. Any method yielding more accurate results may be used.

5.3 Decisions

- (i) If the conclusions regarding the general condition of the body are favourable, the equipment may be kept in service as insulated equipment of its initial class for a further period of not more than three years. If the conclusions of the expert or experts are not acceptable, the equipment may be kept in service only following a satisfactory measurement of the K coefficient according to the procedure described in paragraphs 2.1.1 to 2.3.2 of this appendix; it may then be kept in service for a further period of six years.
- (ii) In the case of heavily insulated equipment, if the conclusions of an expert or experts show the body to be unsuitable for keeping in service in its initial class but suitable for continuing in service as normally insulated equipment, then the body may be kept in service in an appropriate class for a further three years. In this case, the distinguishing marks (as in appendix 4 of this annex) shall be changed appropriately.
- (iii) If the equipment consists of units of serially-produced equipment of a particular type satisfying the requirements of appendix 1, paragraph 6, to this annex and belonging to one owner, then in addition to an inspection of each unit of equipment, the K coefficient of not less than 1% of the number of units involved, may be measured in conformity with the provisions of sections 2.1, 2.2 and 2.3 of this appendix. If the results of the examinations and measurements are acceptable, all the equipment in question may be kept in service as insulating equipment of its initial class for a further period of six years.

Comment to paragraph 5.3:

Some countries consider 0.40 to be the maximum K-value for classes B, C, E and F also by re-approval, and others are of the opinion that re-approval is done by fulfilling paragraphs 5 and 6.

Re-approval can be carried out either by a test station ensuring the maximum K-value for classes B, C, E and F is less than 0.40 W/m².K and 0.70 W/m².K for classes A and D or by fulfilling paragraphs 5 and 6.

6. VERIFYING THE EFFECTIVENESS OF THERMAL APPLIANCES OF EQUIPMENT IN SERVICE

To verify as prescribed in appendix 1, paragraphs 1 (b) and (c), to this annex the effectiveness of the thermal appliance of each item of refrigerated, mechanically refrigerated, heated or mechanically refrigerated and heated equipment in service, the competent authorities may:

Apply the methods described in sections 3.1, 3.2, 3.3 and 3.4 of this appendix; or

Appoint experts to apply the particulars described in sections 5.1 and 5.2 of this appendix, when applicable, as well as the following provisions.

6.1 Refrigerated equipment other than equipment with fixed eutectic accumulators

It shall be verified that the inside temperature of the empty equipment, previously brought to the outside temperature, can be brought to the limit temperature of the class to which the equipment belongs, as prescribed in this annex, and maintained below the said limit temperature for a period t

$$\text{such that } t \geq \frac{12\Delta T}{\Delta T'}$$
 in which

ΔT is the difference between + 30 °C and the said limit temperature, and

$\Delta T'$ is the difference between the mean outside temperature during the test and the class limit temperature, the outside temperature being not lower than + 15 °C.

If the results are acceptable, the equipment may be kept in service as refrigerated equipment of its initial class for a further period of not more than three years.

6.2 Mechanically refrigerated equipment

Independent equipment

- (i) Equipment constructed from 2 January 2012

It shall be verified that, when the outside temperature is not lower than + 15 °C, the inside temperature of the empty equipment can be brought to the class temperature within a maximum period (in minutes), as prescribed in the table below:

Outside temperature	30	29	28	27	26	25	24	23	22	21	20	19	18	17	16	15	°C
Class C, F	360	350	340	330	320	310	300	290	280	270	260	250	240	230	220	210	min
Class B, E	270	262	253	245	236	228	219	211	202	194	185	177	168	160	151	143	min

Class A, D	180	173	166	159	152	145	138	131	124	117	110	103	96	89	82	75	min
------------	-----	-----	-----	-----	-----	-----	-----	-----	-----	-----	-----	-----	----	----	----	----	-----

The inside temperature of the empty equipment must have been previously brought to the outside temperature.

If the results are acceptable, the equipment may be kept in service as mechanically refrigerated equipment of its initial class for a further period of not more than three years.

(ii) Transitional provisions applicable to equipment in service

For equipment constructed prior to the date given in 6.2 (i), the following provisions shall apply:

It shall be verified that, when the outside temperature is not lower than +15° C, the inside temperature of the empty equipment, which has been previously brought to the outside temperature, can be brought within a maximum period of six hours:

In the case of equipment in classes A, B or C, to the minimum temperature, as prescribed in this annex;

In the case of equipment in classes D, E or F, to the limit temperature, as prescribed in this annex.

If the results are acceptable, the equipment may be kept in service as mechanically refrigerated equipment of its initial class for a further period of not more than three years.

Comment to paragraph 6.2 (ii):

Failure to pass the efficiency test is in many cases due to lack of maintenance. To prevent unnecessary burden and additional costs for the owner-operator due to retests, it is strongly recommended that the thermal appliance be maintained properly and checked for correct functioning prior to the efficiency test. (ECE/TRANS/WP.11/220, para. 44)

(iii) Non-independent equipment, the refrigeration unit of which is powered by the engine of the vehicle

It shall be verified that, when the outside temperature is not lower than 15° C, the inside temperature of the empty equipment can be maintained at the class temperature, after cool-down and stabilization, when the engine is running at the idle speed set by the manufacturer (where applicable), for a minimum period of one hour and thirty minutes.

If the results are satisfactory, the equipment may be kept in service as mechanically refrigerated equipment in its initial class for a further period of not more than three years.

(iv) Transitional provisions for non-independent equipment in service:

For equipment constructed prior to 6 January 2018, this provision need not be applied. In this case the equipment shall comply with the requirements of (i) or (ii) of this paragraph as applicable for the date of construction.

6.3 Heated equipment

It shall be verified that the difference between the inside temperature of the equipment and the outside temperature which governs the class to which the equipment belongs as prescribed in this annex (a difference of 22 K in the case of class A, 32 K in the case of class B, 42 K in the case of class C and 52 K in the case of class D) can be achieved and be maintained for not less than 12 hours. If the results are acceptable, the equipment may be kept in service as heated equipment of its initial class for a further period of not more than three years.

6.4 Mechanically refrigerated and heated equipment

The check is carried out in two stages.

- (i) During the first stage, it shall be verified that, when the outside temperature is not lower than + 15 °C, the inside temperature of the empty equipment can be brought to the class temperature within a maximum period (in minutes), as prescribed in the table in paragraph 6.2 of this appendix.

The inside temperature of the empty equipment shall have been previously brought to the outside temperature.

- (ii) In the second stage, it shall be verified that the difference between the inside temperature of the equipment and the outside temperature which governs the class to which the equipment belongs as prescribed in this annex (a difference of 22 K in the case of classes A, E and I, of 32 K in the case of classes B, F and J, of 42 K in the case of classes C, G and K, and of 52 K in the case of classes D, H, and L), can be achieved and maintained for not less than 12 hours.

If the results are acceptable, the equipment may be kept in service as mechanically refrigerated and heated equipment of its initial class for a further period of not more than three years.

[Comment to paragraph 6.4 - Figure showing the positioning of the instruments](#)

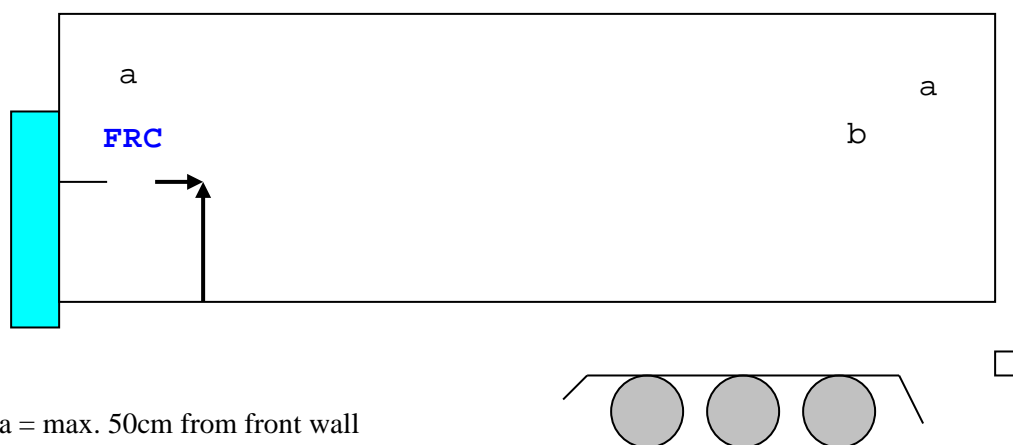

a = max. 50cm from front wall and rear door.

b = min. 15cm and max. 20cm above the floor

6.5 Temperature measuring points

Temperature measuring points protected against radiation shall be placed inside the body and outside the body.

For measuring the inside temperature of the body (T_i), at least 2 temperature measuring points shall be placed inside the body at a maximum distance of 50 cm from the front wall, 50 cm from the rear door at a height of a minimum of 15 cm and a maximum of 20 cm above the floor area.

For measuring the outside temperature of the body (T_e), at least 2 temperature measuring points shall be placed at a distance of at least 10 cm from an outer wall of the body and at least 20 cm from the air inlet of the condenser unit.

The final reading shall be from the warmest point inside the body and the coldest point outside.

6.6 Provisions common to refrigerated, mechanically refrigerated and heated equipment

- (i) If the results are not acceptable, refrigerated, mechanically refrigerated, heated, or mechanically refrigerated and heated equipment may be kept in service in its initial class only if it passes at a testing station the tests described in sections 3.1, 3.2, 3.3 and 3.4 of this appendix; it may then be kept in service in its initial class for a further period of six years.
- (ii) If the equipment consists of units of serially-produced refrigerated, mechanically refrigerated, heated, or mechanically refrigerated and heated equipment of a particular type satisfying the requirements of appendix 1, paragraph 6, to this annex and belonging to one owner, then in addition to an inspection of the thermal appliances to ensure that their general condition appears to be satisfactory, the effectiveness of the cooling or heating appliances of not less than 1% of the number of units may be determined at a testing station in conformity with the provisions of sections 3.1, 3.2, 3.3 and 3.4 of this appendix. If the results of the examinations and of the determination of effectiveness are acceptable, all the equipment in question may be kept in service in its initial class for a further period of six years.

7. PROCEDURE FOR MEASURING THE CAPACITY OF MECHANICAL MULTI-TEMPERATURE REFRIGERATION UNITS AND DIMENSIONING MULTI-COMPARTMENT EQUIPMENT

7.1 Definitions

- (a) Multi-compartment equipment: Equipment with two or more insulated compartments for maintaining a different temperature in each compartment;
- (b) Multi-temperature mechanical refrigeration unit: Mechanical refrigeration unit with compressor and common suction inlet, condenser and two or more evaporators set at different temperatures in the various compartments of multi-compartment equipment;
- (c) Host unit: Refrigeration unit with or without an integral evaporator;
- (d) Unconditioned compartment: a compartment considered to have no evaporator or for which the evaporator is inactive for the purposes of dimensioning calculations and certification;
- (e) Multi-temperature operation: Operation of a multi-temperature mechanical refrigeration unit with two or more evaporators operating at different temperatures in multi-compartment equipment;
- (f) Nominal refrigerating capacity: Maximum refrigerating capacity of the refrigeration unit in mono-temperature operation with two or three evaporators operating simultaneously at the same temperature;
- (g) Individual refrigerating capacity ($P_{\text{ind-evap}}$): The maximum refrigerating capacity of each evaporator in solo operation with the host unit;
- (h) Effective refrigerating capacity ($P_{\text{eff-frozen-evap}}$): The refrigerating capacity available to the lowest temperature evaporator when two or more evaporators are each operating in multi-temperature mode, as prescribed in paragraph 7.3.5.

7.2 Test procedure for multi-temperature mechanical refrigeration units

7.2.1 General procedure

The test procedure shall be as defined in section 4 of this appendix.

The host unit shall be tested in combination with different evaporators. Each evaporator shall be tested on a separate calorimeter, if applicable.

The nominal refrigerating capacity of the host unit in mono-temperature operation, as prescribed in paragraph 7.2.2, shall be measured with a single combination of two or three evaporators including the smallest and largest.

The individual refrigerating capacity shall be measured for all evaporators, each in mono-temperature operation with the host unit, as prescribed in paragraph 7.2.3.

This test shall be conducted with two or three evaporators including the smallest, the largest and, if necessary, a mid-sized evaporator.

If the multi-temperature unit can be operated with more than two evaporators:

- The host unit shall be tested with a combination of three evaporators: the smallest, the largest and a mid-sized evaporator.

- In addition, on demand of the manufacturer, the host unit can be tested optionally with a combination of two evaporators: the largest and smallest.

The tests are done in independent mode and stand by.

7.2.2 Determination of the nominal refrigerating capacity of the host unit

The nominal refrigerating capacity of the host unit in mono-temperature operation shall be measured with a single combination of two or three evaporators operating simultaneously at the same temperature. This test shall be conducted at -20°C and at 0°C.

The air inlet temperature of the host unit shall be +30°C.

The nominal refrigerating capacity at -10°C shall be calculated by linear interpolation from the capacities at -20°C and 0°C.

7.2.3 Determination of the individual refrigerating capacity of each evaporator

The individual refrigerating capacity of each evaporator shall be measured in solo operation with the host unit. The test shall be conducted at -20°C and 0°C. The air inlet temperature of the refrigeration unit shall be +30°C.

The individual refrigerating capacity at -10°C shall be calculated by linear interpolation from the capacities at 0°C and -20°C.

7.2.4 Test of the remaining effective refrigerating capacities of a set of evaporators in multi-temperature operation at a reference heat load

The remaining effective refrigerating capacity shall be measured for each tested evaporator at -20°C with the other evaporator(s) operating under control of a thermostat set at 0 °C with a reference heat load of 20% of the individual refrigerating capacity at -20 °C of the evaporator in question. The air inlet temperature of the host unit shall be +30 °C.

For multi-temperature refrigeration units with more than one compressor such as cascade systems or units with two-stage compression systems, where the refrigerating capacities can be simultaneously maintained in the frozen and chilled compartments, the measurement of the effective refrigerating capacity, shall be done at one additional heat load.

7.3 Dimensioning and certification of refrigerated multi-temperature equipment

7.3.1 General procedure

The refrigerating capacity demand of multi-temperature equipment shall be based on the refrigerating capacity demand of mono-temperature equipment as defined in this appendix.

For multi-compartment equipment, a K coefficient less than or equal to 0.40 W/m².K for the outer body as a whole shall be approved in accordance with subsections 2 to 2.2 of this appendix.

The insulation capacities of the outer body walls shall be calculated using the K coefficient of the body approved in accordance with this Agreement. The insulation capacities of the internal dividing walls shall be calculated using the K coefficients in the table in paragraph 7.3.7.

For issuance of an ATP certificate:

- The nominal refrigerating capacity of the multi-temperature refrigeration unit shall be at least equal to the heat loss through the outer body walls of the equipment as a whole multiplied by the factor 1.75 as specified in paragraph 3.2.6 of this appendix.
- In each compartment, the calculated remaining effective refrigerating capacity at the lowest temperature of each evaporator in multi-temperature operation shall be greater than or equal to the maximum refrigeration demand of the compartment in the most unfavourable conditions, as prescribed in paragraphs 7.3.5 and 7.3.6, multiplied by the factor 1.75 as specified in paragraph 3.2.6 of this appendix.

7.3.2 Conformity of the entire body

The outer body shall have a K value $K \leq 0.40 \text{ W/m}^2 \cdot \text{K}$.

The internal surface of the body shall not vary by more than 20 %.

The equipment shall conform to:

$$P_{\text{nominal}} > 1.75 * K_{\text{body}} * S_{\text{body}} * \Delta T$$

Where:

P_{nominal} is the nominal refrigerating capacity of the multi-temperature refrigeration unit,

K_{body} is the K value of the outer body,

S_{body} is the geometric mean surface area of the full body,

ΔT is the difference in temperature between outside and inside the body.

7.3.3 Determination of the refrigerating demand of chilled evaporators

With the bulkheads in given positions, the refrigerating capacity demand of each chilled evaporator is calculated as follows:

$$P_{\text{chilled demand}} = (S_{\text{chilled-comp}} - \Sigma S_{\text{bulk}}) * K_{\text{body}} * \Delta T_{\text{ext}} + \Sigma (S_{\text{bulk}} * K_{\text{bulk}} * \Delta T_{\text{int}})$$

Where:

K_{body} is the K value given by an ATP test report for the outer body,

$S_{\text{chilled-comp}}$ is the surface of the chilled compartment for the given positions of the bulkheads,

S_{bulk} are the surfaces of the bulkheads,

K_{bulk} are the K values of the bulkheads given by the table in paragraph 7.3.7,

ΔT_{ext} is the difference in temperatures between the chilled compartment and +30°C outside the body,

ΔT_{int} is the difference in temperatures between the chilled compartment and other compartments. For unconditioned compartments a temperature of +20°C shall be used for calculations.

7.3.4 Determination of the refrigerating demand of frozen compartments

With the bulkheads in given positions, the refrigerating capacity demand of each frozen compartment is calculated as follows:

$$P_{\text{frozen demand}} = (S_{\text{frozen-comp}} - \sum S_{\text{bulk}}) * K_{\text{body}} * \Delta T_{\text{ext}} + \sum (S_{\text{bulk}} * K_{\text{bulk}} * \Delta T_{\text{int}})$$

Where:

K_{body} is the K value given by an ATP test report for the outer body,

$S_{\text{frozen-comp}}$ is the surface of the frozen compartment for the given positions of the bulkheads,

S_{bulk} are the surfaces of the bulkheads,

K_{bulk} are the K values of the bulkheads given by the table in paragraph 7.3.7,

ΔT_{ext} is the difference in temperatures between the frozen compartment and +30 °C outside the body,

ΔT_{int} is the difference in temperatures between the frozen compartment and other compartments. For insulated compartments a temperature of +20°C shall be used for calculations.

7.3.5 Determination of the effective refrigerating capacity of frozen evaporators

The effective refrigerating capacity, in given positions of the bulkheads, is calculated as follows:

$$P_{\text{eff-frozen-evap}} = P_{\text{ind-frozen-evap}} * [1 - \sum (P_{\text{eff-chilled-evap}} / P_{\text{ind-chilled-evap}})]$$

Where:

$P_{\text{eff-frozen-evap}}$ is the effective refrigerating capacity of the frozen evaporator with a given configuration,

$P_{\text{ind-frozen-evap}}$ is the individual refrigeration capacity of the frozen evaporator at -20 °C,

$P_{\text{eff-chilled-evap}}$ is the effective refrigeration capacity of each chilled evaporator in the given configuration as defined in paragraph 7.3.6,

$P_{\text{ind-chilled-evap}}$ is the individual refrigerating capacity at -20 °C for each chilled evaporator.

This calculation method is only approved for multi-temperature mechanical refrigeration units with a single one-stage compressor. For multi-temperature refrigeration units with more than one compressor such as cascade systems or units with two-stage compression systems, where the refrigerating capacities can be simultaneously maintained in the frozen and the chilled compartments, this calculation method shall not be used, because it will lead to an underestimation of the effective refrigerating capacities. For this equipment, the effective refrigerating capacities shall be interpolated between the effective refrigerating capacities measured with two different heat loads given in the tests reports as prescribed in 7.2.4.

7.3.6 Conformity declaration

The equipment is declared in conformity in multi-temperature operation if, for each position of the bulkheads, and each distribution of temperature in the compartments:

$$P_{\text{eff-frozen-evap}} \geq 1.75 * P_{\text{frozen demand}}$$

$$P_{\text{eff-chilled-evap}} \geq 1.75 * P_{\text{chilled demand}}$$

Where:

$P_{\text{eff-frozen-evap}}$ is the effective refrigeration capacity of the considered frozen evaporator at the class temperature of the compartment in the given configuration,

$P_{\text{eff-chilled-evap}}$ is the effective refrigeration capacity of the considered chilled evaporator at the class temperature of the compartment in the given configuration,

$P_{\text{frozen demand}}$ is the refrigerating demand of the considered compartment at the class temperature of the compartment in the given configuration as calculated according to 7.3.4,

$P_{\text{chilled demand}}$ is the refrigerating demand of the considered compartment at the class temperature of the compartment in the given configuration as calculated according to 7.3.3.

It shall be considered that all the positions of the bulkheads have been dimensioned if the wall positions from the smallest to the largest compartment sizes are checked by iterative methods whereby no input step change in surface area is greater than 20 %.

Comment to paragraph 7.3.6:

Calculations in conformity with item 7.3.6 can be carried out using a calculation tool approved by the competent authority.

7.3.7 Internal dividing walls

Thermal losses through internal dividing walls shall be calculated using the K coefficients in the following table.

	K coefficient – [W/m ² .K]		Minimum foam thickness [mm]
	Fixed	Removable	
Longitudinal – alu floor	2.0	3.0	25
Longitudinal – GRP floor	1.5	2.0	25
Transversal – alu floor	2.0	3.2	40
Transversal – GRP floor	1.5	2.6	40

K coefficients of movable dividing walls include a safety margin for specific ageing and unavoidable thermal leakages.

For specific designs with additional heat transfer caused by additional thermal bridges compared to a standard design, the partition K coefficient shall be increased.

7.3.8 The requirements of section 7 shall not apply to equipment produced before the entry into force of the requirements and having undergone equivalent tests as multi-temperature equipment. Equipment produced before the entry into force of this section may be operated in international transport but may only be transferred from one country to another with the agreement of the competent authorities of the countries concerned.

8. TEST REPORTS

A test report of the type appropriate to the equipment tested shall be drawn up for each test in conformity with one or other of the models 1 to 12 hereunder.

MODEL No. 1 A

Test Report

Prepared in conformity with the provisions of the Agreement on the International Carriage of Perishable Foodstuffs and on the Special Equipment to be Used for such Carriage (ATP)

Test report No.....

Section 1

Specifications of the equipment (equipment other than tanks for the carriage of liquid foodstuffs)

Approved testing station/expert: ¹

Name

Address

Type of equipment: ²

Make..... Registration number..... Serial number

Date of first entry into service

Tare ³.....kg Carrying capacity ³kg

Body:

Make and type Identification number

Built by

Owned or operated by

Submitted by

Date of construction

Principal dimensions:

Outside: length m, widthm, height..... m

Inside: length m, widthm, height..... m

Total floor area of body m²

Usable internal volume of body m³

MODEL No. 1 A (cont'd)

Method used ^{1,3} Figures used ^{1,3}

Total inside surface area S_i of body m²

Total outside surface area S_e of body m²

Mean surface area: $S = \sqrt{S_i \cdot S_e}$ m²

Specifications of the body walls: ⁴

Top

Bottom

Sides

Structural peculiarities of body: ⁵

Number, () of doors

positions () of vents

and dimensions () of ice-loading apertures.....

Accessories ⁶

.....

K coefficient = ... W/m².K

¹ Delete as necessary (experts only in the case of tests carried out under ATP Annex 1, Appendix 2, sections 5 or 6).

² Wagon, lorry, trailer, semi-trailer, container, etc.

³ State source of information.

⁴ Nature and thickness of materials constituting the body walls, from the interior to the exterior, mode of construction, etc.

⁵ If there are surface irregularities, show how S_i and S_e were determined.

⁶ Meat bars, flettner fans, etc.

MODEL No. 1 B

Test Report

Prepared in conformity with the provisions of the Agreement on the International Carriage of Perishable Foodstuffs and on the Special Equipment to be Used for such Carriage (ATP)

Test report No.....

Section 1

Specifications of tanks for the carriage of liquid foodstuffs

Approved testing station/expert: ¹

Name

Address

Type of tank: ²

Make Registration number Serial number

Date of first entry into service

Tare ³ kg Carrying capacity ³ kg

Tank:

Make and type Identification number

Built by

Owned or operated by

Submitted by

Date of construction

Principal dimensions:

Outside: length of cylinderm, major axis m, minor axis m

Inside: length of cylinder m, major axis m, minor axis m

Usable internal volume m³

MODEL No. 1 B (cont'd)

Internal volume of each compartment	m ³
Total inside surface area S _i of tank	m ²
Inside surface area of each compartment S _{i1}, S _{i2}	m ²
Total outside surface area S _e of tank	m ²
Mean surface area of tank: $S = \sqrt{S_i \cdot S_e}$	m ²
Specifications of the tank walls: ⁴	
Structural peculiarities of the tank: ⁵	
Number, dimensions and description of manholes	
Description of manhole covers	
Number, dimensions and description of discharge piping	
Number and description of tank cradles	
Accessories	

¹ Delete as necessary (experts only in the case of tests carried out under ATP Annex 1, Appendix 2, sections 5 or 6).
² Wagon, lorry, trailer, semi-trailer, container, etc.
³ State source of information.
⁴ Nature and thickness of materials constituting the tank walls, from the interior to the exterior, mode of construction, etc.
⁵ If there are surface irregularities, show how S_i and S_e were determined.

MODEL No. 2 A

Section 2

Measurement in accordance with ATP, Annex 1, Appendix 2, sub-section 2.1, of the overall coefficient of heat transfer of equipment other than tanks for liquid foodstuffs

Testing method: inside cooling/inside heating ¹

Date and time of closure of equipment's doors and other openings:

Averages obtained for hours of continuous operation
(from a.m./p.m. to a.m./p.m.):

(a) Mean outside temperature of body: $T_e = \dots\dots\dots^\circ\text{C} \pm \dots\dots\dots\text{K}$

(b) Mean inside temperature of body: $T_i = \dots\dots\dots^\circ\text{C} \pm \dots\dots\dots\text{K}$

(c) Mean temperature difference achieved: $\Delta T = \dots\dots\dots\text{K}$

Maximum temperature spread:

Outside bodyK

Inside bodyK

Mean temperature of walls of body $\frac{T_e + T_i}{2}$ °C

Operating temperature of heat exchanger ² °C

Dew point of atmosphere outside body during continuous operation ²
..... °C ±K

Total duration of testh

Duration of continuous operationh

Power consumed in exchangers: W_1 W

Power absorbed by fans: W_2 W

Overall coefficient of heat transfer calculated by the formula:

Inside-cooling test ¹ $K = \frac{W_1 - W_2}{S \cdot \Delta T}$

Inside-heating test ¹ $K = \frac{W_1 + W_2}{S \cdot \Delta T}$

$K = \dots\dots\dots \text{W/m}^2.\text{K}$

MODEL No. 2 A (cont'd)

Maximum error of measurement with test used %

Remarks: ³.....

(To be completed only if the equipment does not have thermal appliances:)

According to the above test results, the equipment may be recognized by means of a certificate in accordance with ATP Annex 1, Appendix 3, valid for a period of not more than six years, with the distinguishing mark IN/IR.¹

However, this report shall be valid as a certificate of type approval within the meaning of ATP Annex 1, Appendix 1, paragraph 6 (a) only for a period of not more than six years, that is until

Done at:

on

.....

Testing Officer

¹ Delete as necessary.

² For inside-cooling test only.

³ If the body is not parallelepipedic, specify the points at which the outside and inside temperatures were measured.

MODEL No. 2 B

Section 2

Measurement, in accordance with ATP Annex 1, Appendix 2, sub-section 2.2, of the overall coefficient of heat transfer of tanks for liquid foodstuffs

Testing method: inside heating

Date and time of closure of equipment's openings

Mean values obtained forhours of continuous operation

(from a.m./p.m. to a.m./p.m.):

(a) Mean outside temperature of tank: $T_e = \dots\dots\dots^\circ\text{C} \pm \dots\dots\dots\text{K}$

(b) Mean inside temperature of tank:

$$T_i = \frac{\sum S_{in} \cdot T_{in}}{\sum S_{in}} = \dots\dots\dots^\circ\text{C} \pm \dots\dots\dots\text{K}$$

(c) Mean temperature difference achieved: $\Delta T \dots\dots\dots\text{K}$

Maximum temperature spread:

Inside tankK

Inside each compartmentK

Outside tankK

Mean temperature of tank walls $^\circ\text{C}$

Total duration of testh

Duration of continuous operationh

Power consumed in exchangers: $W_1 \dots\dots\dots\text{W}$

Power absorbed by fans: $W_2 \dots\dots\dots\text{W}$

Overall coefficient of heat transfer calculated by the formula:

$$K = \frac{W_1 + W_2}{S \cdot \Delta T}$$

$K = \dots\dots\dots\text{W/m}^2\cdot\text{K}$

MODEL No. 2 B (cont'd)

Maximum error of measurement with test used %

Remarks: ¹
.....

(To be completed only if the equipment does not have thermal appliances:)

According to the above test results, the equipment may be recognized by means of a certificate in accordance with ATP Annex 1, Appendix 3, valid for a period of not more than six years, with the distinguishing mark IN/IR. ²

However, this report shall be valid as a certificate of type approval within the meaning of ATP Annex 1, Appendix 1, paragraph 6 (a) only for a period of not more than six years, that is until

Done at:.....

on:

Testing Officer

¹ *If the tank is not parallelepipedic, specify the points at which the outside and inside temperatures were measured.*

² *Delete as necessary.*

MODEL No. 3

Section 2

Expert field check of the insulating capacity of equipment in service in accordance with
ATP Annex 1, Appendix 2, section 5

The check was based on test report No..... dated
issued by approved testing station/expert (name and address).....
.....

Condition when checked:

Top

Side walls

End wall

Bottom

Doors and openings

Seals

Cleaning drainholes

Air tightness

K coefficient of the equipment when new (as shown in the previous test report)
..... W/m².K

Remarks:
.....

According to the above test results the equipment may be recognized by means of a certificate in
accordance with ATP Annex 1, Appendix 3, valid for not more than three years, with the distinguishing
mark IN/IR. ¹

Done at

on:
Testing Officer

¹ Delete as necessary.

MODEL No. 4 A

Section 3

Determination of the efficiency of cooling appliances of refrigerated equipment using ice or dry ice by an approved testing station in accordance with ATP Annex 1, Appendix 2, sub-section 3.1, except 3.1.3 (b) and 3.1.3 (c)

Cooling appliance:

Description of cooling appliance

Nature of refrigerant

Nominal refrigerant filling capacity specified
by manufacturerkg

Actual filling of refrigerant used for testkg

Drive independent/dependent/mains-operated ¹

Cooling appliance removable/not removable ¹

Manufacturer

Type, serial number

Year of manufacture

Filling device (description, where situated;
attach drawing if necessary)

.....

Inside ventilation appliances:

Description (number of appliances, etc.)

Power of electric fans W

Delivery ratem³/h

Dimensions of ducts: cross-sectionm², lengthm

Air intake screen; description ¹

¹ Delete if not applicable.

MODEL No. 4 A (cont'd)

Automatic devices

Mean temperatures at beginning of test:

Inside °C ±K

Outside °C ±K

Dew point in test chamber °C ±K

Power of internal heating system W

Date and time of closure of equipment's doors and other openings

Record of mean inside and outside temperatures of body and/or curve showing variation of these temperatures with time

Remarks:
.....

According to the above test results, the equipment may be recognized by means of a certificate in accordance with ATP Annex 1, Appendix 3, valid for a period of not more than six years, with the distinguishing mark

However, this report shall be valid as a certificate of type approval within the meaning of ATP Annex 1, Appendix 1, paragraph 6 (a) only for a period of not more than six years, that is until

Done at:

on:

Testing Officer

MODEL No. 4 B

Section 3

Determination of the efficiency of cooling appliances of refrigerated equipment with eutectic plates by an approved testing station in accordance with ATP Annex 1, Appendix 2, sub-section 3.1, except 3.1.3 (a) and 3.1.3 (c)

Cooling appliance:

Description

Nature of eutectic solution

Nominal eutectic solution filling capacity specified
by manufacturer kg

Latent heat at freezing temperature stated by manufacturerkJ/kg at °C

Cooling appliance removable/not removable ¹

Drive independent/dependent/mains-operated ¹

Manufacturer

Type, serial number

Year of manufacture

Eutectic plates: Make Type

Dimensions and number of plates, where situated;
distance from walls (attach drawing)

.....

Total cold reserve stated by manufacturer for freezing
temperature ofkJ to °C

Inside ventilation appliances (if any):

Description

Automatic devices ..

¹ Delete if not applicable.

MODEL No. 4 B (cont'd)

Mechanical refrigerator (if any):

Make Type No.....

Where situated

Compressor: Make Type

Type of drive

Nature of refrigerant

Condenser

Refrigerating capacity stated by the manufacturer for the specified freezing temperature and an outside temperature of + 30 °CW

Automatic devices:

Make Type

Defrosting (if any)

Thermostat

LP pressostat

HP pressostat

Relief valve

Others.....

Accessory devices:

Electrical heating devices of the door joint:

Capacity by linear metre of the resistor W/m

Linear length of the resistorm

Mean temperatures at beginning of test:

Inside °C ±K

Outside °C ±K

Dew point in test chamber °C ±K

MODEL No. 4 B (cont'd)

Power of internal heating system W

Date and time of closure of equipment's
doors and openings

Period of accumulation of coldh

Record of mean inside and outside temperatures of body
and/or curve showing variation of these temperatures
with time

.....

Remarks:

.....

According to the above test results, the equipment may be recognized by means of a certificate in
accordance with ATP Annex 1, Appendix 3, valid for a period of not more than six years, with the
distinguishing mark

However, this report shall be valid as a certificate of type approval within the meaning of ATP
Annex 1, Appendix 1, paragraph 6 (a) only for a period of not more than six years, that is until
.....

Done at:

on:

Testing Officer

MODEL No. 4 C

Section 3

Determination of the efficiency of cooling appliances of refrigerated equipment using liquefied gases by an approved testing station in accordance with ATP Annex 1, Appendix 2, sub-section 3.1, except 3.1.3 (a) and 3.1.3 (b)

Cooling appliance:

Description

Drive independent/dependent/mains-operated ¹

Cooling appliance removable/not removable ¹

Manufacturer

Type, serial number

Year of manufacture

Nature of refrigerant

Nominal refrigerant filling capacity specified
by manufacturerkg

Actual filling of refrigerant used for testkg

Description of tank

Filling device (description, where situated)

Inside ventilation appliances:

Description (number, etc.)

Power of electric fansW

Delivery ratem³/h

Dimensions of ducts: cross-sectionm², lengthm

Automatic devices

¹ Delete if not applicable.

MODEL No. 4 C (cont'd)

Mean temperatures at beginning of test:

Inside °C ±K

Outside °C ±K

Dew point in test chamber °C ±K

Power of internal heating systemW

Date and time of closure of equipment's
doors and openings

Record of mean inside and outside temperatures of body and/or curve showing
variation of these temperatures with time

.....

Remarks:

.....

According to the above test results, the equipment may be recognized by means of a certificate in
accordance with ATP Annex 1, Appendix 3, valid for a period of not more than six years, with the
distinguishing mark

However, this report shall be valid as a certificate of type approval within the meaning of ATP
Annex 1, Appendix 1, paragraph 6 (a), only for a period of not more than six years, that is until
.....

Done at:

on:

Testing Officer

MODEL No. 5

Section 3

Determination of the efficiency of cooling appliances of mechanically refrigerated equipment by an approved testing station in accordance with ATP Annex 1, Appendix 2, sub-section 3.2

Mechanical refrigerating appliances:

Drive independent/dependent/mains-operated ¹

Mechanical refrigerating appliances removable/not removable ¹

Manufacturer

Type, serial number

Year of manufacture

Nature of refrigerant and filling capacity

Effective refrigerating capacity stated by manufacturer for an outside temperature of + 30 °C and an inside temperature of:

0 °C..... W
-10 °C..... W
-20 °C..... W

Compressor:

Make Type

Drive: electric/thermal/hydraulic ¹

Description

Make Type power kW atrpm

Condenser and evaporator

Motor element of fan(s): make type number

power kW atrpm

Inside ventilation appliances:

Description (number of appliances, etc.)

Power of electric fans W

Delivery ratem³/h

Dimensions of ducts: cross-sectionm², lengthm

¹ Delete if not applicable.

MODEL No. 5 (cont'd)

Automatic devices:

Make Type
Defrosting (if any)
Thermostat
LP pressostat
HP pressostat
Relief valve
Others.....

Mean temperatures at beginning of test:

Inside temperature°C ±K
Outside temperature°C ±K
Dew point in test chamber°C ±K

Power of internal heating system W

Date and time of closure of equipment's
doors and other openings

Record of mean inside and outside temperatures of body and/or curve showing variation
of these temperatures with time

Time between beginning of test and attainment
of prescribed mean inside temperature of bodyh

Remarks:

According to the above test results, the equipment may be recognized by means of a certificate in
accordance with ATP Annex 1, Appendix 3, valid for a period of not more than six years, with the
distinguishing mark

However, this report shall be valid as a certificate of type approval within the meaning of ATP
Annex 1, Appendix 1, paragraph 6 (a), only for a period of not more than six years, that is until
.....

Done at:

on:

.....

Testing Officer

MODEL No. 6

Section 3

Determination of the efficiency of heating appliances of heated equipment by an approved testing station in accordance with ATP Annex 1, Appendix 2, sub-section 3.3

Heating appliance:

Description

Drive independent/dependent/mains-operated ¹

Heating appliance removable/not removable ¹

Manufacturer

Type, serial number

Year of manufacture

Where situated

Overall area of heat exchange surfaces m²

Effective power rating as specified by manufacturer kW

Inside ventilation appliances:

Description (number of appliances, etc.)

Power of electric fans..... W

Delivery ratem³/h

Dimensions of ducts: cross-section m², lengthm

Mean temperatures at beginning of test:

Inside temperature °C ±K

Outside temperature °C ±K

Date and time of closure of equipment's doors and other openings

¹ Delete if not applicable.

MODEL No. 6 (cont'd)

Record of mean inside and outside temperatures of body and/or
curve showing variation of these temperatures with time

.....

Time between beginning of test and attainment of prescribed
mean inside temperature of bodyh

Where applicable, mean heating output during test to
maintain prescribed temperature difference ² between
inside and outside of body W

Remarks:

.....

According to the above test results, the equipment may be recognized by means of a certificate in
accordance with ATP Annex 1, Appendix 3, valid for a period of not more than six years, with the
distinguishing mark

However, this report shall be valid as a certificate of type approval within the meaning of ATP
Annex 1, Appendix 1, paragraph 6 (a), only for a period of not more than six years, that is until
.....

Done at:

on:

Testing Officer

² *Increased by 35% for new equipment.*

MODEL No. 7

Section 3

Determination of the efficiency of cooling and heating appliances of mechanically refrigerated and heated equipment by an approved testing station in accordance with ATP Annex 1, Appendix 2, subsection 3.4

Mechanical refrigerating appliances:

Drive independent/dependent/mains-operated¹

Mechanical refrigerating appliances removable/not removable¹

Manufacturer

Type, serial number

Year of manufacture

Nature of refrigerant and filling capacity

Effective refrigerating capacity stated by manufacturer for an outside temperature of + 30 °C and an inside temperature of:

0 °C W

-10 °C W

-20 °C W

Compressor:

Make Type

Drive: electric/thermal/hydraulic¹

Description.....

Make Type power..... kW at.....rpm

Condenser and evaporator.....

Motor element of fan(s): make..... type..... number

power kW atrpm

Heating appliance:

Description

Drive independent/dependent/mains-operated¹

Heating appliance removable/not removable¹

Manufacturer.....

Type, serial number

Year of manufacture

Where situated.....

MODEL No. 7 (cont'd)

Overall area of heat exchange surfaces..... m²

Effective power rating as specified by manufacturer kW

Inside ventilation appliances:

Description (number of appliances, etc.)

Power of electric fans W

Delivery ratem³/h

Dimensions of ducts: cross-section m², lengthm

Automatic devices:

Make Type

Defrosting (if any)

Thermostat

LP pressostat

HP pressostat

Relief valve

Others

Mean temperatures at beginning of test:

Inside °C ± K

Outside °C ± K

Dew point in test chamber² °C ± K

Power of internal heating system W

Date and time of closure of equipment's
doors and openings

Record of mean inside and outside temperatures of body
and/or curve showing variation of these temperatures
with time

MODEL No. 7 (cont'd)

Time between beginning of test and attainment
of prescribed mean inside temperature of bodyh

Where applicable, mean heating output during test to
maintain prescribed temperature difference³ between
inside and outside of body⁴W

Remarks:

According to the above test results, the equipment may be recognized by means of a
certificate in accordance with ATP Annex 1, Appendix 3, valid for a period of not more
than six years, with the distinguishing mark

However, this report shall be valid as a certificate of type approval within the meaning of
ATP Annex 1, Appendix 1, paragraph 6 (a), only for a period of not more than six years,
that is until.....

Done at:

on:

Testing Officer

1 *Delete if not applicable.*
2 *Only for cooling appliances.*
3 *Increased by 35% for new equipment.*
4 *Only for heating appliances.*

MODEL No. 8

Section 3

Expert field check of the efficiency of cooling appliances of refrigerated equipment in service in accordance with ATP Annex 1, Appendix 2, sub-section 6.1

The check was conducted on the basis of report No
dated, issued by approved
testing station/expert (name, address)

Cooling appliance:

Description

Manufacturer

Type, serial number

Year of manufacture

Nature of refrigerant

Nominal refrigerant filling capacity
specified by manufacturerkg

Actual filling of refrigerant used for testkg

Filling device (description, where situated)

Inside ventilation appliances:

Description (number of appliances, etc.)

Power of electric fans W

Delivery ratem³/h

Dimensions of ducts: cross-section m², lengthm

Condition of cooling appliance and ventilation appliances

.....

.....

Inside temperature attained °C

At an outside temperature of °C

MODEL No. 8 (cont'd)

Inside temperature of the equipment before the refrigerating appliance is started °C

Total running time of the refrigerating unith

Time between beginning of test and attainment of prescribed mean inside temperature of bodyh

Check on operation of thermostat

For refrigerated equipment with eutectic plates:

Period of operation of the cooling appliance for freezing of the eutectic solutionh

Period during which inside air temperature is maintained after the appliance is switched offh

Remarks:

.....

According to the above test results, the equipment may be recognized by means of a certificate in accordance with ATP Annex 1, Appendix 3, valid for a period of not more than three years, with the distinguishing mark

Done at:

on:

Testing Officer

MODEL No. 9

Section 3

Expert field check of the efficiency of cooling appliances of mechanically refrigerated equipment in service in accordance with ATP Annex 1, Appendix 2, sub-section 6.2

The check was conducted on the basis of report No..... dated
issued by approved testing station/expert (name, address)
.....

Mechanical refrigerating appliances:

Manufacturer

Type, serial number

Year of manufacture

Description

Effective refrigerating capacity specified by manufacturer for an outside temperature of +30 °C and an inside temperature of

0 °C W

-10 °C W

-20 °C W

Nature of refrigerant and filling capacity kg

Inside ventilation appliances:

Description (number of appliances, etc.)

Power of electric fans W

Delivery rate m³/h

Dimensions of ducts: cross-section m², length m

Condition of mechanical refrigerating appliance and inside ventilation appliances
.....

MODEL No. 9 (cont'd)

Inside temperature attained °C
At an outside temperature of °C
and with a relative running time of %
Running timeh
Check on operation of thermostat
Remarks:
.....

According to the above test results, the equipment may be recognized by means of a certificate in accordance with ATP Annex 1, Appendix 3 valid for a period of not more than three years, with the distinguishing mark

Done at:

on:

Testing Officer

MODEL No. 10

Section 3

Expert field check of the efficiency of heating appliances of heated equipment in service in accordance with ATP Annex 1, Appendix 2, sub-section 6.3

The check was conducted on the basis of report No. dated
issued by approved testing station/expert (name, address)
.....

Mode of heating:

Description
Manufacturer
Type, serial number
Year of manufacture
Where situated
Overall area of heat exchange surfaces m²
Effective power rating as specified by manufacturer kW

Inside ventilation appliances:

Description (number of appliances, etc.)
Power of electric fans W
Delivery rate m³/h

Dimensions of ducts: cross-section m², length m

Condition of heating appliance and inside ventilation appliances
.....
.....

Inside temperature attained °C

MODEL No. 10 (cont'd)

At an outside temperature of °C

and with a relative running time of %

Running timeh

Check on operation of thermostat

Remarks:

.....

According to the above test results, the equipment may be recognized by means of a certificate in accordance with ATP Annex 1, Appendix 3, valid for a period of not more than three years, with the distinguishing mark

Done at:

on:

Testing Officer

MODEL No. 11

Section 3

Expert field check of the efficiency of cooling and heating appliances of mechanically refrigerated and heated equipment in service in accordance with ATP Annex 1, Appendix 2, subsection 6.4

The check was conducted on the basis of report No. dated,
issued by approved testing station/expert (name, address)

Mechanical refrigerating appliances:

Manufacturer

Type, serial number

Year of manufacture

Description

Effective refrigerating capacity stated by manufacturer for an outside temperature of + 30 °C and an inside temperature of:

 0 °C W

 -10 °C W

 -20 °C W

Nature of refrigerant and filling capacity kg

Heating appliance:

Description

Manufacturer

Type, serial number

Year of manufacture

Where situated

Overall area of heat exchange surfaces m²

Effective power rating as specified by manufacturer kW

Inside ventilation appliances:

Description (number of appliances, etc.)

Power of electric fans W

Delivery rate m³/h

Dimensions of ducts: cross-section m², length m

MODEL No. 11 (cont'd)

Condition of cooling appliance, heating appliance and inside ventilation appliances

.....

Inside temperature attained °C

At an outside temperature of °C

and with a relative running time of %

Running timeh

Check on operation of thermostat

Remarks:

.....

According to the above test results, the equipment may be recognized by means of a certificate in accordance with ATP Annex 1, Appendix 3, valid for a period of not more than three years, with the distinguishing mark

Done at:.....

on:

Testing Officer

Results of measurements and refrigerating performance

(Mean temperature of the air to the inlet(s) of the refrigeration unit °C)

Speed of rotation	Internal temperature			Power of internal fan heater	Power absorbed by the unit cooler fan ⁴	Fuel or electrical power consumption	Mean temperature around the body	Effective refrigerating capacity	
	Mean	Inlet to evaporator	Mean					W	
	Compressor ³	Alternator ³	Fans ³	W	W	W or l/hr	°C	°C	W
Nominal
Minimal

MODEL No.12 (cont'd)

MODEL No. 12 (cont'd)

(b) Test method and results:

Test method ¹: heat balance method/enthalpy difference method

In a calorimeter box of mean surface area = m²
measured value of the U-coefficient of a box
fitted with a refrigeration unit: W/°C,
at a mean wall temperature of °C.
..... °C.

In an item of transport equipment:
measured value of the U-coefficient of an item of transport equipment fitted with a
refrigeration unit: W/°C,
at a mean wall temperature of °C.

Method employed for the correction of the U-coefficient of the body as a function of the mean wall
temperature of the body:
.....
.....

Maximum errors of determination of:
U-coefficient of the body
refrigerating capacity of the unit

(c) Checks

Temperature regulator: Setting °C Differential °C

Functioning of the defrosting device ¹: satisfactory/unsatisfactory

Air flow volume leaving the evaporator: value measuredm³/h

at a pressure ofPa

Existence of a means of supplying heat to the evaporator for setting the thermostat between 0 and
12 °C ¹: yes/no

MODEL No. 12 (cont'd)

(d) Remarks

According to the above test results, this report shall be valid as a certificate of type approval within the meaning of ATP Annex 1, Appendix 1, paragraph 6 (a) only for a period of not more than six years, that is until:

.....
.....
.....

Done at:

On:

Testing Officer

-
- ¹ *Delete where applicable.*
 - ² *Value indicated by the manufacturer.*
 - ³ *Where applicable.*
 - ⁴ *Enthalpy difference method only.*

Annex 1, Appendix 3

A. Model form of certificate of compliance of the equipment, as prescribed in Annex 1, Appendix 1, paragraph 3

FORM OF CERTIFICATE FOR INSULATED, REFRIGERATED, MECHANICALLY REFRIGERATED, HEATED OR MECHANICALLY REFRIGERATED AND HEATED EQUIPMENT USED FOR THE INTERNATIONAL CARRIAGE OF PERISHABLE FOODSTUFFS BY LAND

Certificates of compliance of equipment issued before 2 January 2011 in accordance with the requirements regarding the model of the certificate in Annex 1, Appendix 3 in force until 1 January 2011 shall remain valid until their original date of expiry.

Certificates of compliance issued before the date of entry into force of the modification to item 3 of the model certificate (30 September 2015) shall remain valid until their original date of expiry.

2	XXXXXXXXXX ³	INSULATED	REFRIGERATED	MECHANICALLY REFRIGERATED	HEATED
---	-------------------------	-----------	--------------	------------------------------	--------

/ CERTIFICATE⁵ ATP XXXXXXXXX

/ Issued pursuant to the Agreement on the International Convention for the Safe Carriage of *Foodstuffs and on the Special Equipment to be Used for such Carriage (ATP)*

1. / Issuing authority: XXXXXXXXXXXXXXXXXXXXXXXX

2. / Equipment⁶: XXXXXXXXXXXXXXXXXXXXXXXX

3. / Registration number^a: XXXXXXXXXXXX / Vehicle identification number^a: XXXXXXXXXXXXXXXXXXXXXXXX

 / allotted by: XXXXXXXXXXXXXXXXXXXXXXXX

 Insulated box: **MARK, MODEL, SERIAL NUMBER, MONTH AND YEAR OF MANUFACTURE** XXXXXXXXXXXXXXXX

4. Owner or operated by: XXXXXXXXXXXXXXXX

5. / Submitted by: XX

6. / Is approved as:⁷ XX

6.1. / Independent;⁸ MARK, MODEL, REFRIGERANT, SERIAL NUMBER/YEAR OF MANUFACTURE

6.1.1 / Not independent;⁸ MARK, MODEL, REFRIGERANT, SERIAL NUMBER/YEAR OF MANUFACTURE

6.1.2 / Removable;

6.1.3 / Not removable.

7. / Basis of issue of certificate: / This certificate is issued on the basis of:¹

7.1. / Tests of the equipment; / conformity with a reference

7.1.3 / A periodic inspection.

7.2. / Specify: XX

7.2.1 / The testing station: XX

7.2.2 / The nature of the tests:⁹ XX

7.2.3 / The number(s) of the report(s):

7.2.4 NNNNNNNN (TESTING STATION) YYYY/MM/DD and NNNNNNNN (TESTING STATION) YYYY/MM/DD

7.2.5 / The K coefficient: 0.nn W/m²K

	11	Nominal capacity	Evap.1	Evap.2	Evap.3
7.2.5	°C	xxxxx W	xxxxx W	xxxxx W	xxxxx W
	°C	xxxxx W	xxxxx W	xxxxx W	xxxxx W
	°C	xxxxx W	xxxxx W	xxxxx W	xxxxx W

7.2.5 / The effective refrigerating capacity at an outside temperature of 30°C and an inside temperature of:¹⁰

7.3. / Number of openings and special equipment

7.3.1 / Number of doors: X / rear door X / side door(s) X

7.3.2 / Number of vents: X

7.3.3 / Hanging meat equipment: X

7.4. / Others

8. / This certificate is valid until: MONTH & YEAR

8.1. / Provided that:

8.1.1 / The insulated body and, where applicable, the thermal appliance is maintained in good condition; and

8.1.2 / No material alteration is made to the thermal appliances;

9. / Done by: XXXXXXXXXXXXXXXXXXXXXXXX

 XXXXXXXXXXXXXXXXXXXXXXXXXXXX

 XXXXXXXXXXXXXXXXXXXXXXXXXXXX

 XXXXXXXXXXXXXXXXXXXXXXXXXXXX

10. / On: YYYY/MM/DD

CERTIFIED DUPLICATE¹²

Do not print this stamp on the original Certificate
(Officer name)
(Competent or authorized authority)

LOGO TYPE¹³

Security stamp (relief, ultraviolet, etc.)

Original document

/ The competent authority
XXXXXXXXXXXXXXXXXXXXXXXXXXXX¹⁴

/ Responsible for the ATP

(Officer name)

^a / Not mandatory

These footnotes shall not be printed on the certificate itself.

The areas in grey shall be replaced by the translation in the language of the country issuing the ATP Certificate.

- 1 Strike out what does not apply.*
- 2 Distinguishing sign of the country, as used in international road traffic.*
- 3 The number (figures, letters, etc.) indicating the authority issuing the certificate and the approval reference.*
- 4 The test procedure for new multi-temperature equipment appears in section 7 of annex 1, appendix 2. A test procedure for in-service multi-temperature equipment has not yet been determined. Multi-temperature equipment is insulated equipment with two or more compartments for different temperatures in each compartment.*
- 5 The blank certificate shall be printed in the language of the issuing country and in English, French or Russian; the various items shall be numbered as in the above model.*
- 6 State type (wagon, lorry, trailer, semi-trailer, container, etc.); in the case of tank equipment for carriage of liquid foodstuffs, add the word "tank".*
- 7 Enter here one or more of the descriptions listed in Appendix 4 of Annex 1, together with the corresponding distinguishing mark or marks.*
- 8 Write the mark, model, refrigerant, serial number and year of manufacture of the equipment.*
- 9 Measurement of the overall coefficient of heat transfer, determination of the efficiency of cooling appliances, etc.*
- 10 Where determined in conformity with the provisions of Appendix 2, paragraph 3.2 of this Annex.*
- 11 The effective cooling capacity of each evaporator depends on the number of evaporators fixed at the condensing unit.*
- 12 In case of loss, a new Certificate can be provided or, instead of it, a photocopy of the ATP Certificate bearing a special stamp with "CERTIFIED DUPLICATE" (in red ink) and the name of the certifying officer, his signature, and the name of the competent authority or authorized body.*
- 13 Security stamp (relief, fluorescent, ultraviolet, or other safety mark that certifies the origin of the certificate).*
- 14 If applicable, mention the way the power for issuing ATP Certificates is delegated.*
- 15 Write the mark, model, serial number of the manufacturer and month and year of manufacture of the insulated body. All the serial numbers of insulated equipment (containers) having an internal volume of less than 2 m³ shall be listed. It is also acceptable to collectively list these numbers, i.e. from number ... to number*

[Comment to item 8.1.2 in the model certificate of compliance:](#)

The replacement of components of the thermal appliance does not constitute a material alteration, in as much as replacement components do not reduce the quality of the appliance performance.

B. Certification plate of compliance of the equipment, as provided for in Annex 1, Appendix 1, paragraph 3

1. The certification plate shall be affixed to the equipment permanently and in a clearly visible place adjacent to any other approval plate issued for official purposes. The plate, conforming to the model reproduced below, shall take the form of a rectangular, corrosion-resistant and fire-resistant plate measuring at least 160 mm by 100 mm. The following particulars shall be indicated legibly and indelibly on the plate in at least the English or French or Russian language:
 - (a) The Latin letters "ATP" followed by the words "APPROVED FOR TRANSPORT OF PERISHABLE FOODSTUFFS";
 - (b) "APPROVAL NUMBER" followed by the distinguishing sign (in international road traffic) of the State in which the approval was granted and the number (figures, letters, etc.) of the approval reference;
 - (c) "EQUIPMENT NUMBER" followed by the individual number assigned to identify the particular item of equipment (which may be the manufacturer's number);
 - (d) "ATP MARK" followed by the distinguishing mark prescribed in annex 1, appendix 4, corresponding to the class and the category of the equipment;
 - (e) "VALID UNTIL" followed by the date (month and year) when the approval of the unit of equipment expires. If the approval is renewed following a test or inspection, the subsequent date of expiry may be added on the same line.
2. The letters "ATP" and the letters of the distinguishing mark should be approximately 20 mm high. Other letters and figures should not be less than 5 mm high.

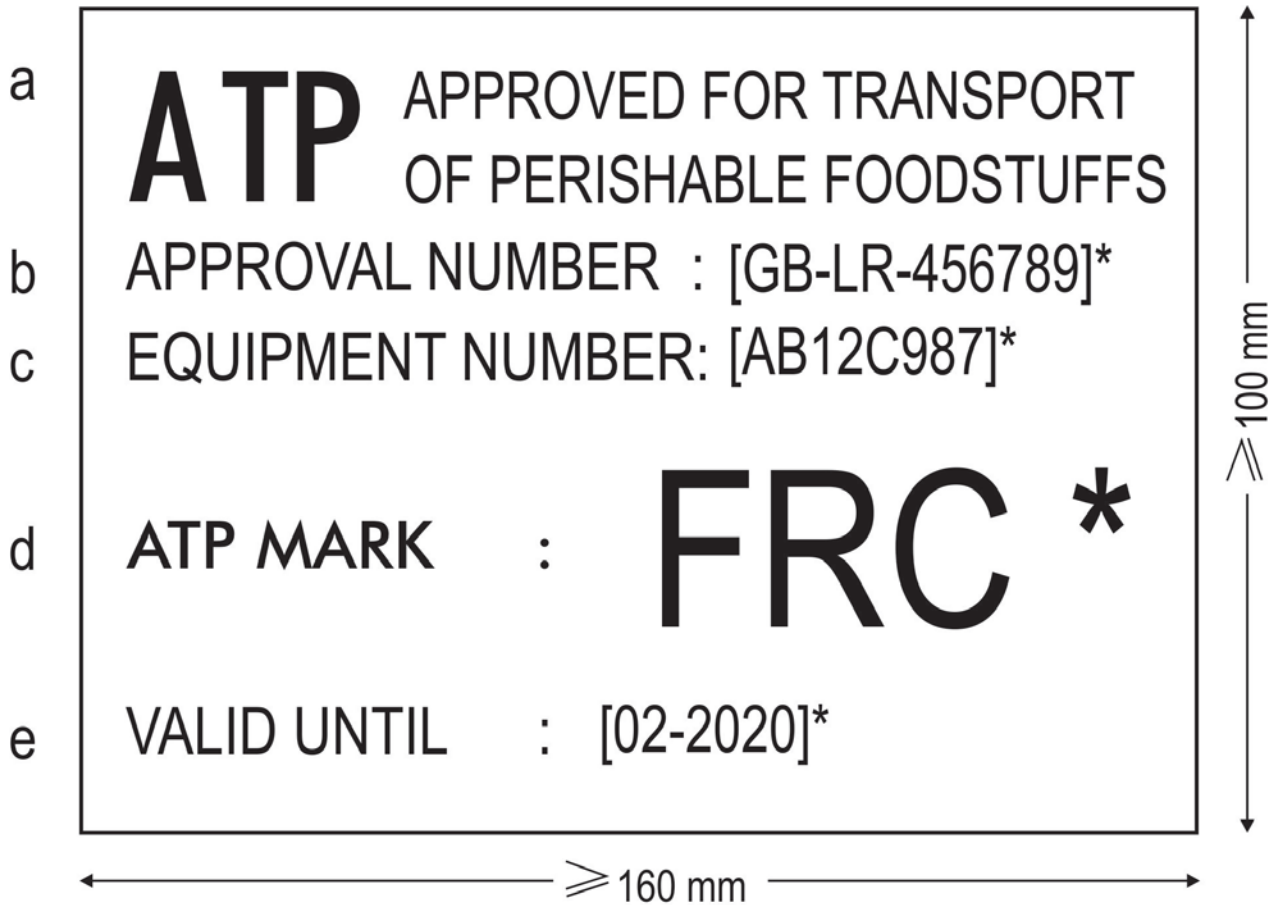

* The particulars in square brackets are given by way of example.

Annex I, Appendix 4

DISTINGUISHING MARKS TO BE AFFIXED TO SPECIAL EQUIPMENT

The distinguishing marks prescribed in appendix 1, paragraph 4 to this annex shall consist of capital Latin letters in dark blue on a white ground. The height of the letters shall be at least 100 mm for the classification marks and at least 50 mm for the expiry dates. For special equipment, such as a laden vehicle with maximum mass not exceeding 3.5 t, the height of the classification marks could likewise be 50 mm and at least 25 mm for the expiry dates.

The classification and expiry marks shall at least be affixed externally on both sides in the upper corners near the front.

The marks shall be as follows:

<u>Equipment</u>	<u>Distinguishing mark</u>
Normally insulated equipment	IN
Heavily insulated equipment	IR
Class A refrigerated equipment with normal insulation	RNA
Class A refrigerated equipment with heavy insulation	RRA
Class B refrigerated equipment with heavy insulation	RRB
Class C refrigerated equipment with heavy insulation	RRC
Class D refrigerated equipment with normal insulation	RND
Class D refrigerated equipment with heavy insulation	RRD
Class A mechanically refrigerated equipment with normal insulation	FNA
Class A mechanically refrigerated equipment with heavy insulation	FRA
Class B mechanically refrigerated equipment with heavy insulation	FRB
Class C mechanically refrigerated equipment with heavy insulation	FRC
Class D mechanically refrigerated equipment with normal insulation	FND
Class D mechanically refrigerated equipment with heavy insulation	FRD

<u>Equipment</u>	<u>Distinguishing mark</u>
Class E mechanically refrigerated equipment with heavy insulation	FRE
Class F mechanically refrigerated equipment with heavy insulation	FRF
Class A heated equipment with normal insulation	CNA
Class A heated equipment with heavy insulation	CRA
Class B heated equipment with heavy insulation	CRB
Class C heated equipment with heavy insulation	CRC
Class D heated equipment with heavy insulation	CRD
Class A mechanically refrigerated and heated equipment with normal insulation	BNA
Class A mechanically refrigerated and heated equipment with heavy insulation	BRA
Class B mechanically refrigerated and heated equipment with heavy insulation	BRB
Class C mechanically refrigerated and heated equipment with heavy insulation	BRC
Class D mechanically refrigerated and heated equipment with heavy insulation	BRD
Class E mechanically refrigerated and heated equipment with heavy insulation	BRE
Class F mechanically refrigerated and heated equipment with heavy insulation	BRF
Class G mechanically refrigerated and heated equipment with heavy insulation	BRG
Class H mechanically refrigerated and heated equipment with heavy insulation	BRH
Class I mechanically refrigerated and heated equipment with heavy insulation	BRI
Class J mechanically refrigerated and heated equipment with heavy insulation	BRJ
Class K mechanically refrigerated and heated equipment with heavy insulation	BRK
Class L mechanically refrigerated and heated equipment with heavy insulation	BRL

If the equipment is fitted with a removable or non-independent thermal appliance and if special conditions exist for the use of the thermal appliance, the distinguishing mark or marks shall be supplemented by the letter X in the following cases:

1. FOR REFRIGERATED EQUIPMENT:

Where the eutectic plates have to be placed in another chamber for freezing;

2. FOR MECHANICALLY REFRIGERATED EQUIPMENT AND MECHANICALLY REFRIGERATED AND HEATED EQUIPMENT:

2.1 Where the compressor is powered by the vehicle engine;

2.2 Where the refrigeration or refrigeration-heating unit itself or a part is removable, which would prevent its functioning.

The date (month, year) entered under section A, item 8 in appendix 3 of this annex as the date of expiry of the certificate issued in respect of the equipment shall be quoted under the distinguishing mark or marks aforesaid.

Model:

FRC 02 - 2020

02 = month (February)) of expiry of the
2020= year) certificate

Annex 2

**1. SELECTION OF EQUIPMENT AND TEMPERATURE CONDITIONS
TO BE OBSERVED FOR THE CARRIAGE OF QUICK
(DEEP)-FROZEN AND FROZEN FOODSTUFFS**

1. For the carriage of the following quick (deep)-frozen and frozen foodstuffs, the transport equipment has to be selected and used in such a way that during carriage the highest temperature of the foodstuffs at any point of the load does not exceed the indicated temperature.

By that means the equipment used for the transport of quick-frozen foodstuffs shall be fitted with the device referred to in appendix 1 to this annex. If however one should proceed to the verification of the temperature of the foodstuff, this shall be done according to the procedure laid down in appendix 2 to this annex.

2. Accordingly, the temperature of the foodstuffs at any point in the load must be at or below the indicated value on loading, during carriage and on unloading.
3. Where it is necessary to open the equipment, e.g. to carry out inspections, it is essential to ensure that the foodstuffs are not exposed to procedures or conditions contrary to the objectives of this annex and those of the International Convention on the Harmonization of Frontier Controls of Goods.
4. During certain operations, such as defrosting the evaporator of mechanically refrigerated equipment, a brief rise of the temperature of the surface of the foodstuffs of not more than 3 °C in a part of the load, e.g. near the evaporator, above the appropriate temperature may be permitted.

Ice cream	-20 °C
Frozen or quick (deep)-frozen fish, fish products, molluscs and crustaceans and all other quick (deep)-frozen foodstuffs	-18 °C
All other frozen foodstuffs (except butter)	-12 °C
Butter	-10 °C

Deep-frozen and frozen foodstuffs mentioned below to be immediately further processed at destination: ¹

- Butter
- Concentrated fruit juice

¹ *The deep-frozen and frozen foodstuffs listed, when intended for immediate further processing at destination, may be permitted gradually to rise in temperature during carriage so as to arrive at their destination at temperatures no higher than those specified by the sender and indicated in the transport contract. This temperature should not be higher than the maximum temperature authorized for the same foodstuff when refrigerated as mentioned in annex 3. The transport document shall state the name of the foodstuff, whether it is deep-frozen or frozen and that it is immediately to be further processed at destination. This carriage shall be undertaken with ATP-approved equipment without use of a thermal appliance to increase the temperature of the foodstuffs.*

Annex 2, Appendix 1

MONITORING OF AIR TEMPERATURE FOR TRANSPORT OF QUICK-FROZEN PERISHABLE FOODSTUFFS

The transport equipment shall be fitted with an instrument capable of measuring and recording air temperatures and storing the data obtained (hereinafter referred to as the instrument) to monitor the air temperatures to which quick-frozen foodstuffs intended for human consumption are subjected.

The instrument shall be verified in accordance with EN 13486 (Temperature recorders and thermometers for the transport, storage and distribution of chilled, frozen, deep-frozen/quick-frozen food and ice cream – Periodic verification) by an accredited body and the documentation shall be available for the approval of ATP competent authorities.

The instrument shall comply with standard EN 12830 (Temperature recorders for the transport, storage and distribution of chilled, frozen, deep-frozen/quick-frozen food and ice cream – Tests, performance, suitability).

Temperature recordings obtained in this manner must be dated and stored by the operator for at least one year or longer, according to the nature of the food.

Comments to Annex 2, Appendix 1:

1. *The measuring instrument must measure air temperature in transport equipment with an accuracy of at least ± 1 °C.*
2. *The measuring instrument must allow for measuring air temperature and recording/logging the measured value of the air temperature:*
 - *At least once every 5 minutes if the duration of the journey does not exceed 24 hours;*
 - *At least once every 15 minutes if the duration of the journey is between 24 hours and 7 days;*
 - *At least once every 60 minutes if the duration of the journey exceeds 7 days.*
3. *The recording instrument should make it possible to determine whether the instrument or its components for the measurement and recording and storage of the values of air temperatures have shut down during the carriage of quick-frozen perishable foodstuffs. (ECE/TRANS/WP.11/222, para. 37).*
4. *Where it is possible, the measuring instrument should be placed inside the body of the transport equipment in the area with the highest air temperature in accordance with the requirements of annex 2, paragraph 2 of ATP:*
 - *In the case of upper cold air distribution systems, near (to the left or right of) the bottom of the doorway furthest away from the refrigeration unit;*
 - *In the case of lower cold air distribution systems, in the middle of the portion above the doorway furthest away from the refrigeration unit;*
5. *The instrument shall be adequately protected to avoid damage caused by moving parts of equipment or contact with cargo items during loading and unloading or shifting or partial or complete collapse of stacks of cargo during carriage.*

No means of protection of the instruments (e.g. protective housing or placement of the measuring instrument in a protective housing in a recess in a wall of the transport equipment, if any) should affect the accuracy of the air temperature measurements inside the transport equipment.

(ECE/TRANS/WP.11/226, para. 46)

Annex 2, Appendix 2

**PROCEDURE FOR THE SAMPLING AND MEASUREMENT OF TEMPERATURE
FOR CARRIAGE OF CHILLED, FROZEN AND QUICK-FROZEN
PERISHABLE FOODSTUFFS**

2. A. GENERAL CONSIDERATIONS

1. Inspection and measurement of temperatures stipulated in annexes 2 and 3 should be carried out so that the foodstuffs are not exposed to conditions detrimental to the safety or quality of the foodstuffs. Measuring of food temperatures should be carried out in a refrigerated environment, and with the minimum delays and minimum disruption of transport operations.
2. Inspection and measurement procedures, as referred to in paragraph 1, shall preferably be carried out at the point of loading or unloading. These procedures should not normally be carried out during transport, unless serious doubt exists about the conformity of the temperatures of the foodstuffs stipulated in annexes 2 and 3.
3. Where possible, the inspection should take account of information provided by temperature monitoring devices during the journey before selecting those loads of perishable foodstuffs for sampling and measurement procedures. Progression to temperature measurement of the food should only be undertaken where there is reasonable doubt of the temperature control during carriage.
4. Where loads have been selected, a non-destructive measurement (between-case or between-pack) should at first be used. Only where the results of the non-destructive measurement do not conform with the temperatures laid down in annexes 2 or 3 (taking into account allowable tolerances), are destructive measurements to be carried out. Where consignments or cases have been opened for inspection, but no further action has been taken, they should be resealed giving the time, date, place of inspection, and the official stamp of the inspection authority.

3. B. SAMPLING

5. The types of package selected for temperature measurement shall be such that their temperature is representative of the warmest point of the consignment.
6. Where it is necessary to select samples during transport whilst the consignment is loaded, two samples should be taken from the top and bottom of the consignment adjacent to the opening edge of each door or pair of doors.
7. Where samples are taken during unloading of the consignment, four samples should be chosen from any of the following locations:
 - top and bottom of the consignment adjacent to the opening edge of the doors;
 - top rear corners of the consignment (i.e. furthest away from the refrigeration unit);
 - centre of the consignment;
 - centre of the front surface of the consignment (i.e. closest to the refrigeration unit);
 - top or bottom corners of the front surface of the consignment (i.e. closest to the return air intake of the refrigeration unit).
8. In the case of chilled foods in annex 3, samples should also be taken from the coldest location to ensure that freezing has not occurred during transportation.

C. TEMPERATURE MEASUREMENT OF PERISHABLE FOODSTUFFS

9. The temperature measuring probe should be precooled to as close to the product temperature as possible before measurement.

I. Chilled foods

10. Non-destructive measurement. Measurement between-case or between-pack should be made with a probe with a flat head, which gives a good surface contact, low thermal mass, and high thermal conductivity. When placing the probe between the cases or food packs, there should be sufficient pressure to give a good thermal contact, and sufficient length of probe inserted to minimize conductivity errors.
11. Destructive measurement. A probe with a rigid, robust stem and sharpened point should be used, made from a material which is easy to clean and disinfect. The probe should be inserted into the centre of the food pack, and the temperature noted when a steady reading is reached.

II. Frozen and quick-frozen foods

12. Non-destructive measurement. Same as paragraph 10.
13. Destructive measurement. Temperature probes are not designed to penetrate frozen foods. Therefore it is necessary to make a hole in the product in which to insert the probe. The hole is made by a precooled product penetration instrument, which is a sharp pointed metallic instrument such as an ice punch, hand drill or an auger. The diameter of the hole should provide a close fit to that of the probe. The depth to which the probe is inserted will depend on the type of product:
- (i) Where product dimensions allow, insert the probe to a depth of 2.5 cm from the surface of the product;
 - (ii) Where (i) is not possible because of the size of the product, the probe should be inserted to a minimum depth from the surface of 3 to 4 times the diameter of the probe;
 - (iii) It is not possible or practical to make a hole in certain foods because of their size or composition e.g. diced vegetables. In these cases, the internal temperature of the food package should be determined by insertion of a suitable sharp-stemmed probe to the centre of the pack to measure the temperature in contact with the food.

After inserting the probe, the temperature should be read when it has reached a steady value.

5. D. GENERAL SPECIFICATIONS FOR THE MEASURING SYSTEM

14. The measuring system (probe and read-out) used in determining temperature shall meet the following specifications:
- (i) the response time should achieve 90% of the difference between the initial and final reading within three minutes;
 - (ii) ¹ the system must have an accuracy of ± 0.5 °C within the measurement range -20°C to + 30 °C;
 - (iii) ¹ the measuring accuracy must not change by more than 0.3 °C during operation in the ambient temperature range -20°C to + 30°C;
 - (iv) the display resolution of the instrument should be 0.1 °C;
 - (v) ¹ the accuracy of the system should be checked at regular intervals;
 - (vi) the system should have a current certificate of calibration from an approved institution;
 - (vii) the electrical components of the system should be protected against undesirable effects due to condensation of moisture;
 - (viii) the system should be robust and shock proof.

6. E. ALLOWABLE TOLERANCES IN THE MEASUREMENT OF TEMPERATURE

15. Certain tolerances should be allowed in the interpretation of temperature measurements:
- (i) operational - in the case of frozen and quick-frozen foods, a brief rise of up to 3 °C on the temperature permitted in annex 2 is allowed for the surface temperature of the food;
 - (ii) methodology - non-destructive measurement can give up to a maximum of 2°C difference in the reading compared to the true product temperature measurement, especially with the thickness of cardboard in case packaging. This tolerance does not apply to the destructive measurement of temperature.

¹ *The procedure will be defined.*

Annex 3**7. SELECTION OF EQUIPMENT AND TEMPERATURE CONDITIONS TO BE OBSERVED FOR THE CARRIAGE OF CHILLED FOODSTUFFS**

1. For the carriage of the following chilled foodstuffs, the transport equipment has to be selected and used in such a way that during carriage the highest temperature of the foodstuffs at any point of the load does not exceed the indicated temperature. If, however, the verification of the temperature of the foodstuff is carried out, it shall be done according to the procedure laid down in Appendix 2 to Annex 2 to this Agreement.
2. Accordingly, the temperature of the foodstuffs at any point in the load must not exceed the temperature as indicated below on loading, during carriage and on unloading.
3. Where it is necessary to open the equipment, e.g. to carry out inspections, it is essential to ensure that the foodstuffs are not exposed to procedures or conditions contrary to the objectives of this Annex and those of the International Convention on the Harmonization of Frontier Controls of Goods.
4. The temperature control of foodstuffs specified in this Annex should be such as not to cause freezing at any point of the load.

		<i>Maximum temperature</i>
I.	Raw milk ¹	+ 6 °C
II.	Red meat ² and large game (other than red offal)	+ 7 °C
III.	Meat products, ³ pasteurized milk, butter, fresh dairy products (yoghurt, kefir, cream and fresh cheese ⁴), ready cooked foodstuffs (meat, fish, vegetables), ready to eat prepared raw vegetables and vegetable products ⁵ , concentrated fruit juice and fish products ³ not listed below	Either at + 6 °C or at temperature indicated on the label and/or on the transport documents
IV.	Game (other than large game), poultry ² and rabbits	+ 4 °C
V.	Red offal ²	+ 3 °C
VI.	Minced meat ²	Either at +2 °C or at temperature indicated on the label and/or on the transport documents
VII.	Untreated fish, molluscs and crustaceans ⁶	On melting ice or at temperature of melting ice

¹ When milk is collected from the farm for immediate processing, the temperature may rise during carriage to +10 °C.

² Any preparations thereof.

³ Except for products fully treated by salting, smoking, drying or sterilization.

⁴ "Fresh cheese" means a non-ripened (non-matured) cheese which is ready for consumption shortly after manufacturing and which has a limited conservation period.

⁵ Raw vegetables which have been diced, sliced or otherwise size reduced, but excluding those which have only been washed, peeled or simply cut in half.

⁶ Except for live fish, live molluscs and live crustaceans.

ATP Examples of Good Practice (Not an official part of the ATP)

GUIDELINES FOR VERIFICATION OF TRANSPORT EQUIPMENT USED FOR ROAD TRANSPORT OF PERISHABLE FOODSTUFFS

INSPECTION OF ISOTHERMAL PROPERTIES OF ROAD TRANSPORT EQUIPMENT

Transport equipment has to be equipped with a valid certificate or a certification plate and a distinguishing mark.
Examples of the most important identification data:

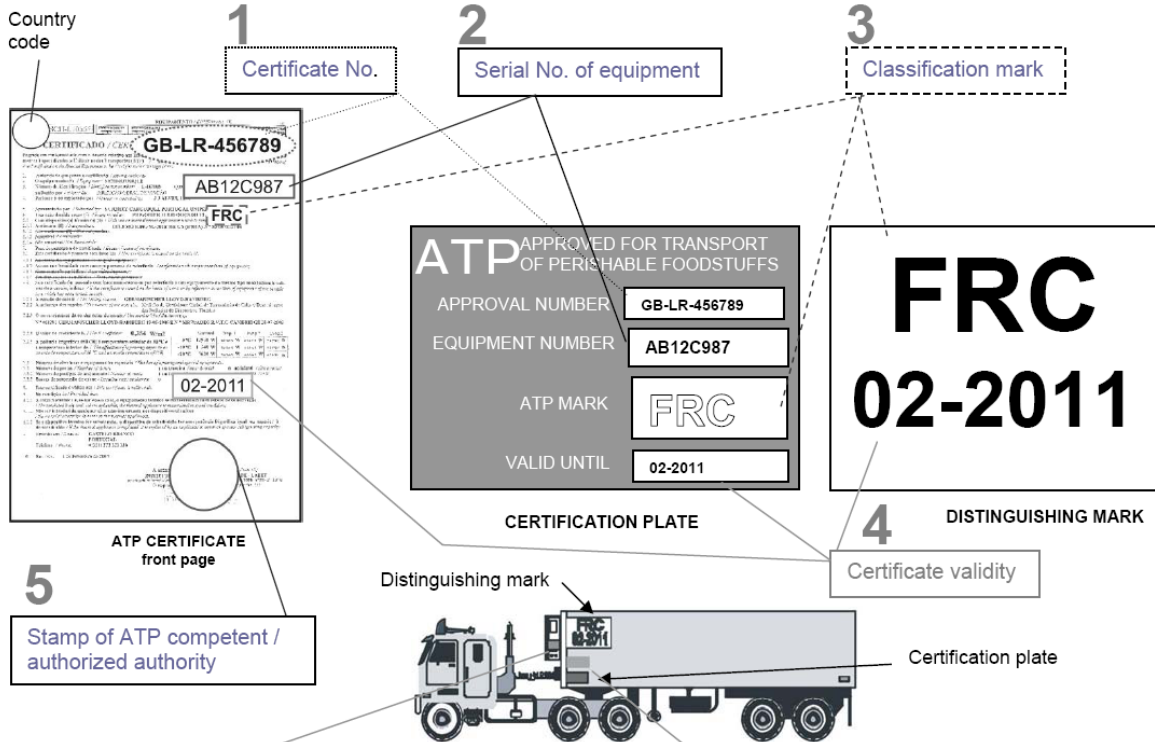

Country of manufacture or letters used in international road traffic	
Name of manufacturer or company	
Model (figures and/or letters)	
Serial number	
Month and year of manufacture	

MANUFACTURER'S PLATE
placed on the thermal appliance

Country of manufacture or letters used in international road traffic	
Name of manufacturer or company	
Model (figures and/or letters)	
Serial number	AB12C987
Month and year of manufacture	

MANUFACTURER'S PLATE *
placed on the insulated body of "insulated", "refrigerated", "mechanically refrigerated" or "heated" transport equipment
* optional

MONITORING OF AIR TEMPERATURES FOR TRANSPORT OF QUICK-FROZEN PERISHABLE FOODSTUFFS

The transport equipment must be fitted with a suitable recording instrument to monitor, at frequent and regular intervals, the air temperatures to which quick-frozen foodstuffs intended for human consumption are subjected.

CHECK: Do the measuring instruments comply with standards EN 12830 and EN 13486? **YES / NO**
Is the calibration certificate valid? **YES / NO**

Temperature recordings obtained in this manner must be dated and stored by the operator for at least one year or longer, according to the nature of the food. Measuring instruments shall comply with the provisions of this Appendix one year after the date of entry into force of the above provision. Measuring instruments already installed, but which do not conform to the above standards before this date, can continue to be used until 31 December 2009.

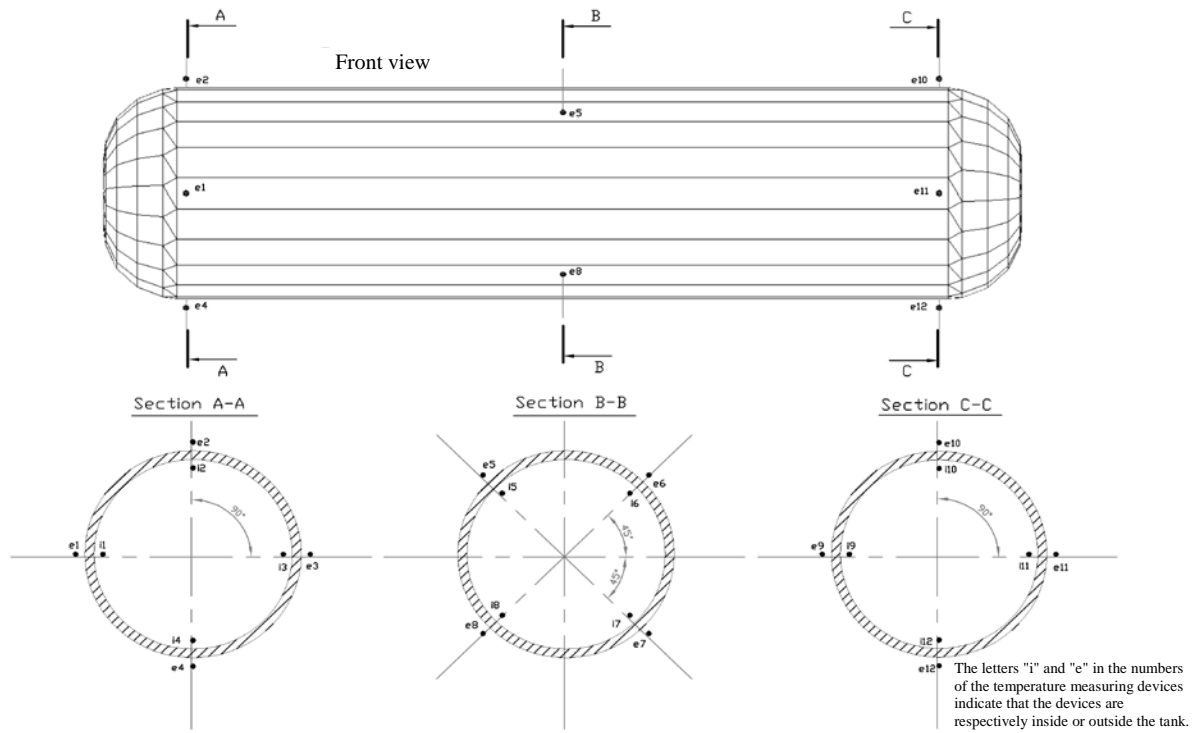

Figure 1 Placement of devices for measuring air temperature inside and outside a tank with one compartment.

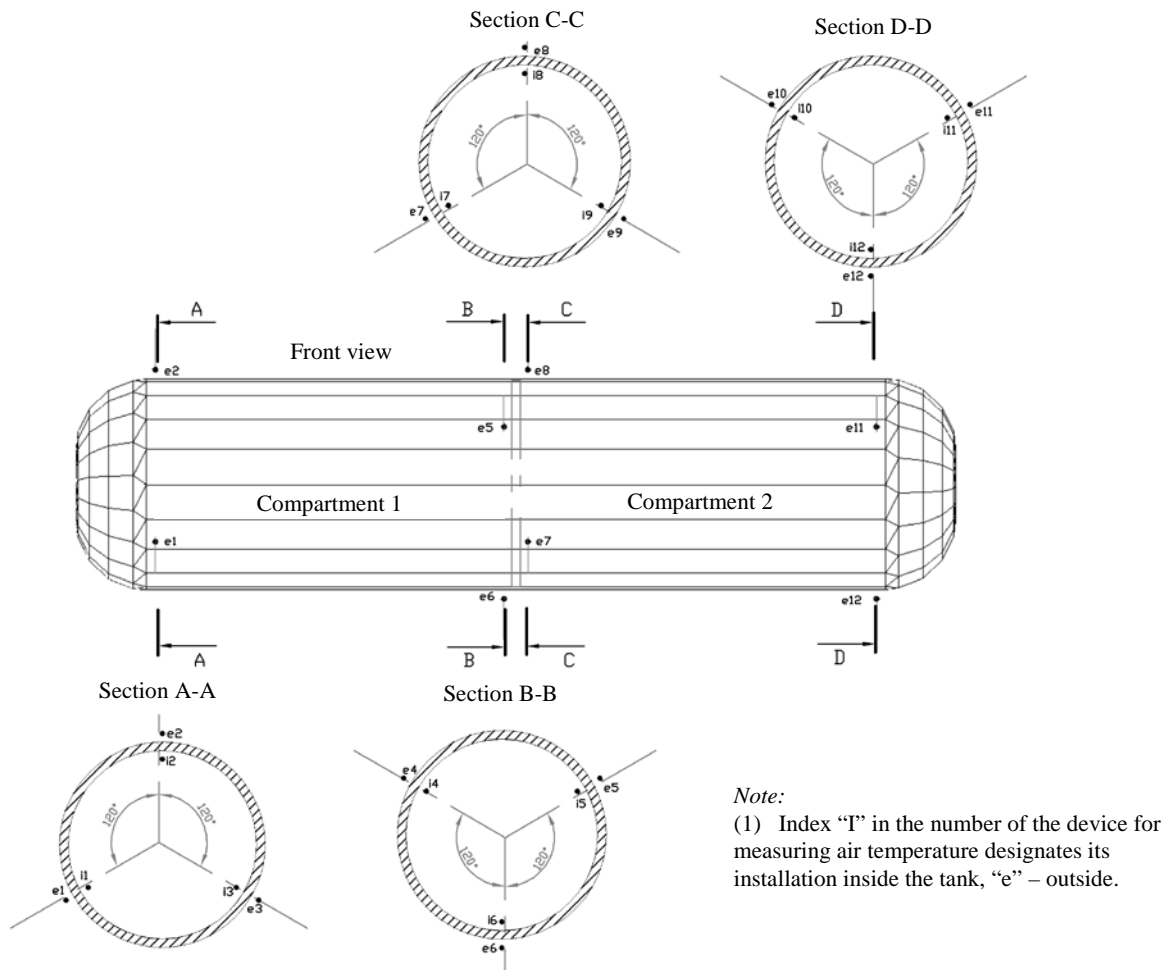

Figure 2 Placement of devices for measuring air temperature inside and outside a tank with two compartments.

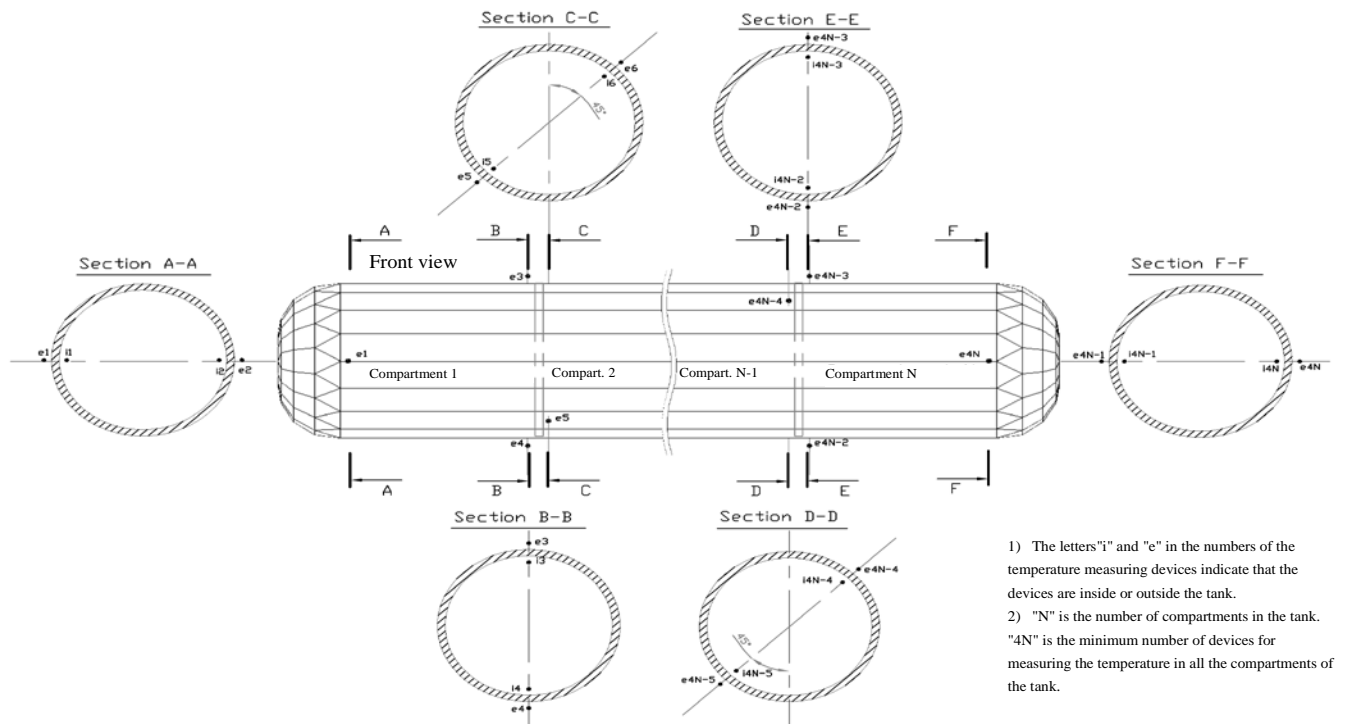

Figure 3 Placement of devices for measuring temperatures inside and outside tanks with three or more compartments.