

**ECONOMIC COMMISSION FOR EUROPE** Informal document SC.3 No. 2 (2009)Rev.1

INLAND TRANSPORT COMMITTEE 12 October 2009

WORKING PARTY ON INLAND WATER  
TRANSPORT

Fifty-third session  
Geneva, 4-6 November 2009  
Item 5 (a) of the provisional agenda

ENGLISH  
Original: ENGLISH, FRENCH AND  
RUSSIAN

---

## **EUROPEAN CODE FOR INLAND WATERWAYS (CEVNI)**

### Draft revised text of annexes to European Code for Inland Waterways

#### Note by secretariat

1. This document contains a draft of the revised text of annexes to the European Code for Inland Waterways (CEVNI), prepared by the small informal working group on CEVNI in accordance with the decisions adopted by the thirty-fifth session of the Working Party on the Standardization of Technical and Safety Requirements in Inland Navigation (ECE/TRANS/SC.3/WP.3/70, paras.6-19). The document takes into account the final comments from Governments and River Commissions received after publication on 31 July 2009 of the first draft of the revised text in Informal document SC.3 1(2009).
2. The text also includes the amendments adopted during the fifty-first and fifty-second sessions of the Working Party on Inland Water Transport. The official adoption of these amendments has been postponed until the next substantial revision of CEVNI (ECE/TRANS/SC.3/178, paras. 21-24 and ECE/TRANS/SC.3/181, paras. 22-23). The current supplement to CEVNI with “Specific Requirements in the National Regulations of Belarus, Kazakhstan, the Republic of Moldova, the Russian Federation and Ukraine that Differ at Present from the Provisions of CEVNI” will be reproduced in the new edition of the code after Annex 10.
3. For technical reasons, changes are not highlighted. The list of all amendments will be published in document ECE/TRANS/SC.3/2009/4.

**Annex 1**

**DISTINGUISHING LETTER OR GROUP OF LETTERS  
INDICATING COUNTRY OF VESSEL'S HOME PORT  
OR PLACE OF REGISTRATION**

AUSTRIA	<b>A</b>	MALTA	<b>MLT</b>
BELARUS	<b>BY</b>	NETHERLANDS	<b>N</b>
BELGIUM	<b>B</b>	NORWAY	<b>NO</b>
BOSNIA AND HERZEGOVINA	<b>BIH</b>	POLAND	<b>PL</b>
BULGARIA	<b>BG</b>	PORTUGAL	<b>P</b>
CROATIA	<b>HR</b>	REPUBLIC OF MOLDOVA	<b>MD</b>
CZECH REPUBLIC	<b>CZ</b>	ROMANIA	<b>R</b>
FINLAND	<b>FI</b>	RUSSIAN FEDERATION	<b>RUS</b>
FRANCE	<b>F</b>	SERBIA	<b>SRB</b>
GERMANY	<b>D</b>	SLOVAKIA	<b>SK</b>
HUNGARY	<b>HU</b>	SLOVENIA	*
ITALY	<b>I</b>	SWEDEN	<b>SE</b>
LITHUANIA	<b>LT</b>	SWITZERLAND	<b>CH</b>
LUXEMBOURG	<b>L</b>	UKRAINE	<b>UA</b>

---

\* Code to be confirmed by the Government of Slovenia.

**Annex 2**

**DRAUGHT SCALES  
ON INLAND WATERWAY VESSELS**

1. Draught scales shall be graduated in units not larger than 1 decimetre, from the light water-line to the maximum draught level, in the form of clearly visible bands painted alternately in two different colours.

The graduation shall be indicated by figures painted beside the scale not more than 5 decimetres apart and at the top of the scale; and the position of the intervals shall be fixed and punched, incised or welded marks.

2. If the vessel bears tonnage scales meeting the requirements of paragraph 1 above, such tonnage scales may serve instead of draught scales.

**Annex 3**

**VISUAL SIGNALS (MARKING) ON VESSELS**

**1. GENERAL**

1.1 The sketches which follow relate to the signals (marking) provided for in the articles of chapter 3 of CEVNI, but not to those provided for in, or authorized by, the footnotes.

1.2 The sketches are for guidance only; reference should be made to the text of the regulations which alone is authoritative.







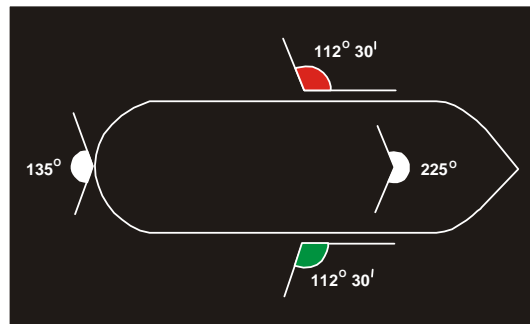

In the case of additional markings which may be prescribed, the sketches illustrate:

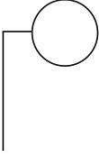
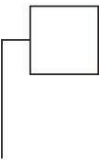
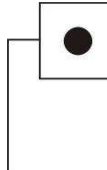
- either the additional markings alone; or
- where necessary for clarity, both the basic marking (or one of the possible basic markings) and the additional marking.

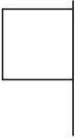
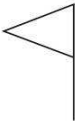
Only the additional marking is described below the sketch.



1.3 Explanation of symbols:

- a  Fixed light visible from all directions  
(a light projecting an uninterrupted beam throughout  
a horizontal arc of 360o).
- b  Fixed light visible over a limited horizontal arc.  
A light which is invisible to the observer is  
marked by a dot in the centre. 
- c  Scintillating light.
- d  Optional light.
- e  Board or flag (article 3.03).
- f  Pennant (article 3.03).
- g  Ball (article 3.04).
- h  Cylinder (article 3.04).
- i  Cone (article 3.04).
- j  Bicone (article 3.04).
- k  Radar reflector.

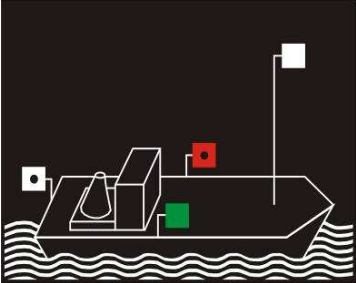
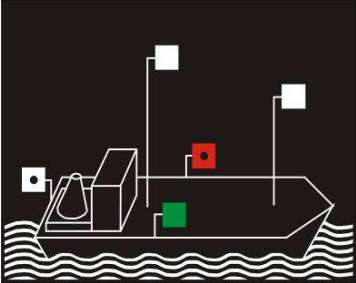
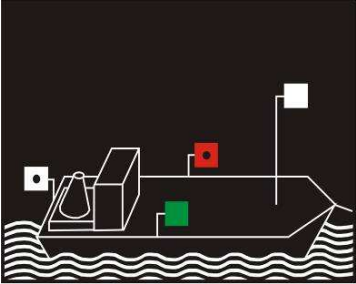
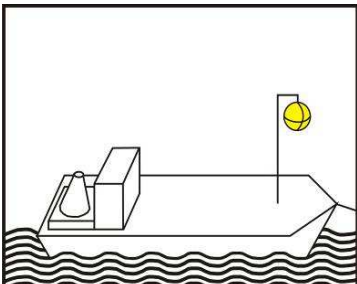
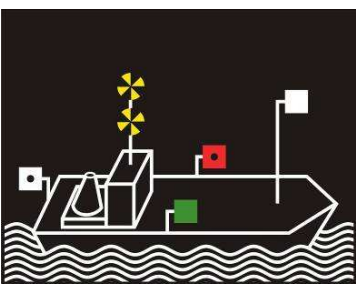
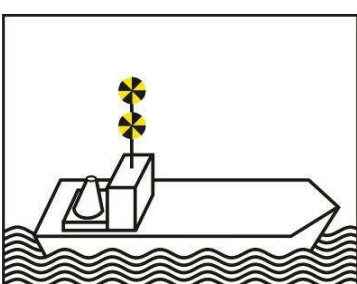
Night	Sketch	Day
<b>2. MARKING WHEN UNDER WAY</b>		
	<b>1</b>	
<p>Article 3.08, paragraph 1: Motorized vessels proceeding alone.</p>		
	<b>2</b>	
<p>Article 3.08, paragraph 2: Motorized vessels proceeding alone with a second masthead light. Compulsory for vessels more than 110 m long.</p>		
	<b>3</b>	
<p>Article 3.08, paragraph 3: Motorized vessel temporarily preceded by an auxiliary motorized vessel.</p>		
	<b>4</b>	
<p>Article 3.08, paragraph 4: High-speed motorized vessel proceeding alone.</p>		

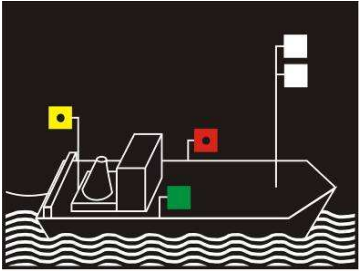
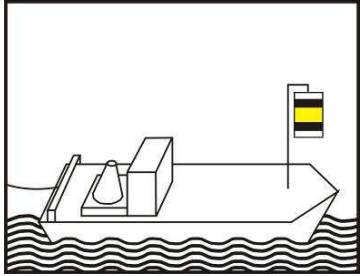
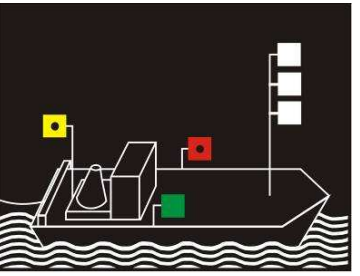
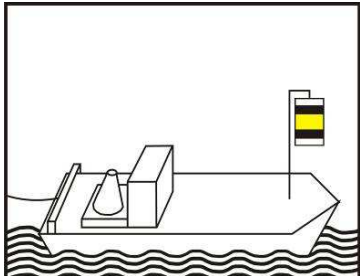
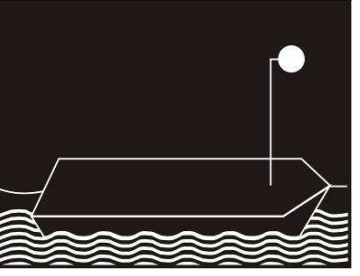
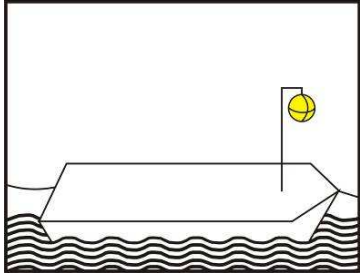
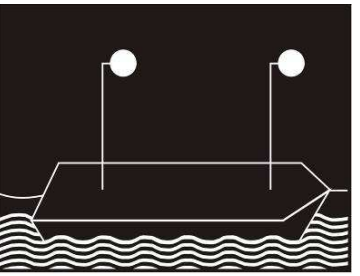
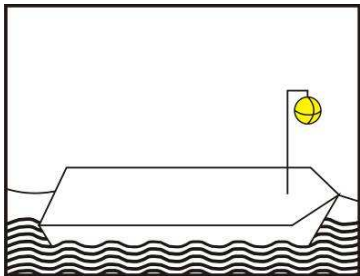
Night	Sketch	Day
	<p><b>5</b></p>	
<p>Article 3.09, paragraph 1: Motorized vessel leading a towed convoy alone or as an auxiliary.</p>		
	<p><b>6</b></p>	
<p>Article 3.09, paragraph 2: Each of several motorized vessels leading a towed convoy or as auxiliaries, when several vessels are proceeding side by side.</p>		
	<p><b>7</b></p>	
<p>Article 3.09, paragraph 3: Towed vessels.</p>		
	<p><b>8</b></p>	
<p>Article 3.09, paragraph 3, letter a: Section of a towed convoy more than 110 m long.</p>		

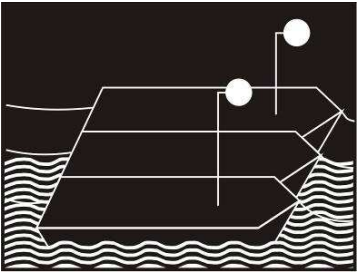
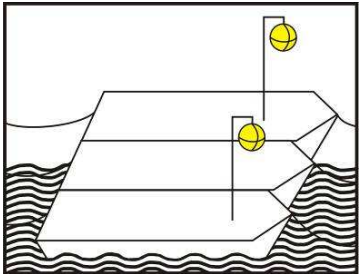
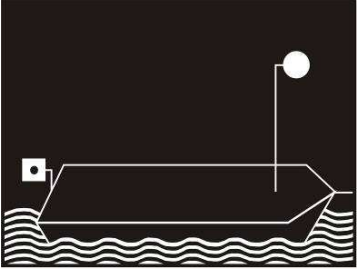
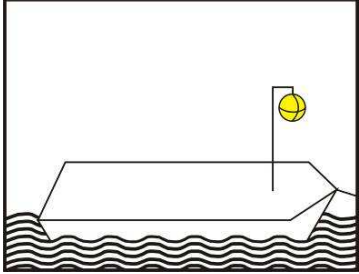
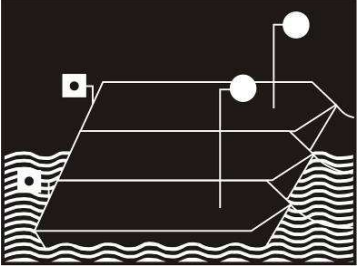
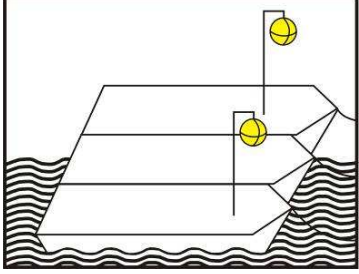
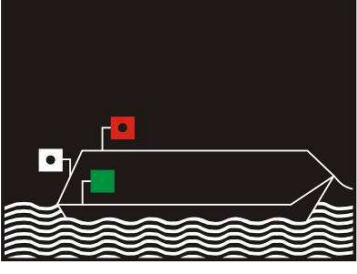
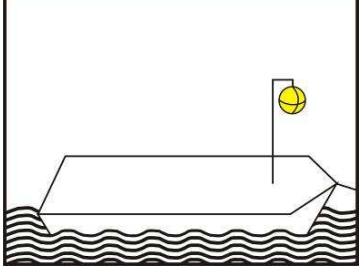
Night	Sketch	Day
	<p><b>9</b></p>	
<p>Article 3.09, paragraph 3, letter b: Section of a towed convoy comprising a row of more than two vessels coupled side by side.</p>		
	<p><b>10</b></p>	
<p>Article 3.09, paragraph 4: Last section of a towed convoy.</p>		
	<p><b>11</b></p>	
<p>Article 3.09, paragraph 4: Towed vessels forming the last section of a convoy.</p>		
	<p><b>12</b></p>	
<p>Article 3.09, paragraph 6: Towed seagoing vessels coming directly from or leaving for the sea.</p>		

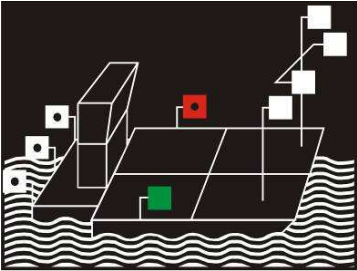
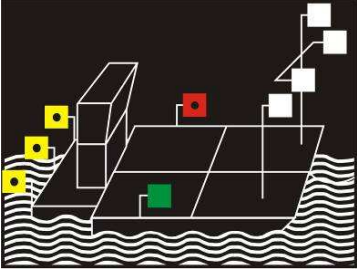
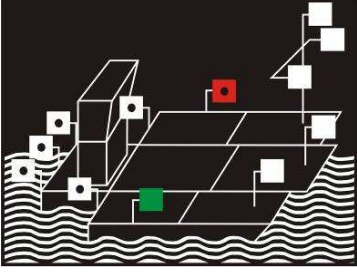
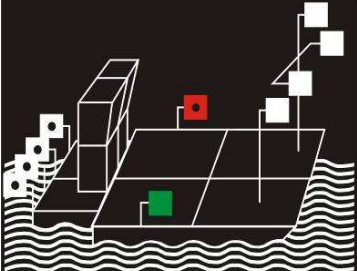

Night	Sketch	Day
	<p><b>13</b></p>	
<p>Article 3.10, paragraph 1: Pushed convoys.</p>		
	<p><b>14</b></p>	
<p>Article 3.10, paragraph 1, letter c.ii: Pushed convoys, when more than two vessels are visible from astern over the full width.</p>		
	<p><b>15</b></p>	
<p>Article 3.10, paragraph 2: Pushed convoys preceded by one or more auxiliary motorized vessels.</p>		
	<p><b>16</b></p>	
<p>Article 3.10, paragraph 4: Pushed convoys with two pushers.</p>		

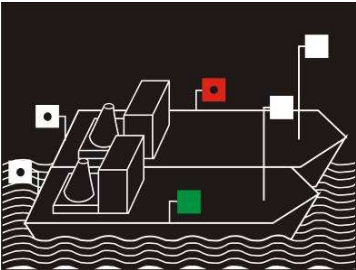
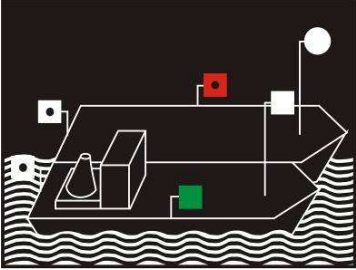
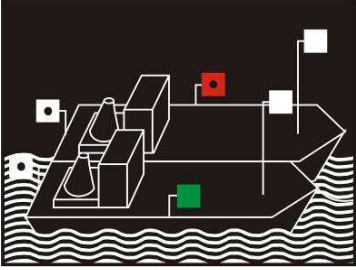
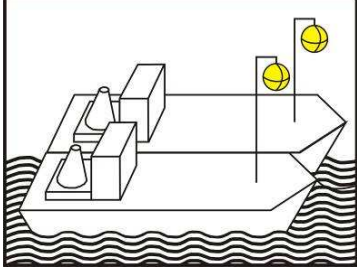
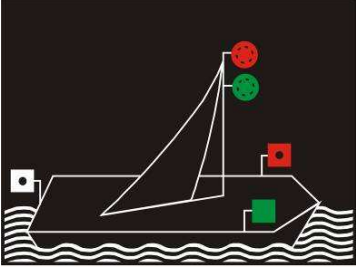
Night	Sketch	Day
	<p><b>17</b></p>	
<p>Article 3.11, paragraph 1: Side-by-side formations: two motorized vessels.</p>		
	<p><b>18</b></p>	
<p>Article 3.11, paragraph 1: Side-by-side formations: one motorized and one non-motorized vessel.</p>		
	<p><b>19</b></p>	
<p>Article 3.11, paragraph 2: Side-by-side formations preceded by one or more auxiliary motorized vessels.</p>		
	<p><b>20</b></p>	
<p>Article 3.12: Sailing vessels.</p>		

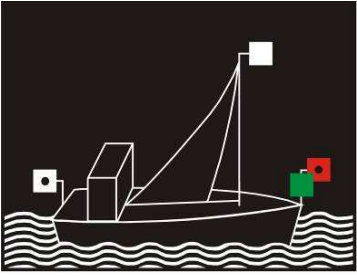
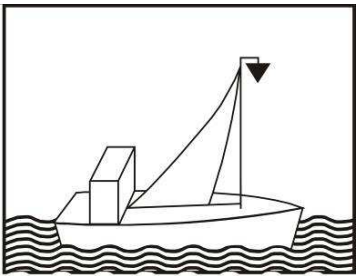
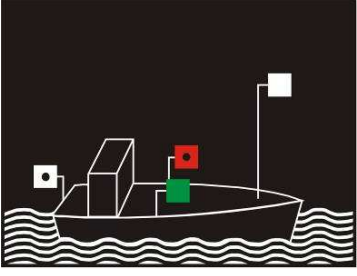
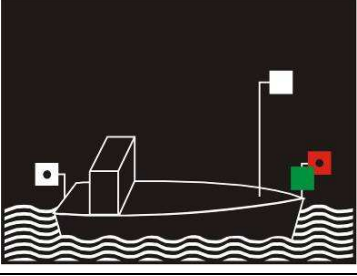
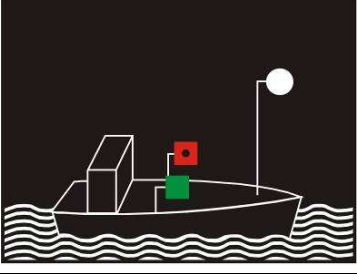
Night	Sketch	Day
	<p><b>21</b></p>	
<p>Article 3.12, paragraph 3: Vessels proceeding under sail and making use at the same time of its own mechanical means of propulsion.</p>		
	<p><b>22</b></p>	
<p>Article 3.13, paragraph 1: Motorized small craft proceeding alone.</p>		
	<p><b>23</b></p>	
<p>Article 3.13, paragraph 1: Motorized small craft proceeding alone with side lights side by side or in the same lamp at or near the bow.</p>		
	<p><b>24</b></p>	
<p>Article 3.13, paragraph 1: Motorized small craft proceeding alone: the masthead light replaced by a bright white light visible from all directions.</p>		

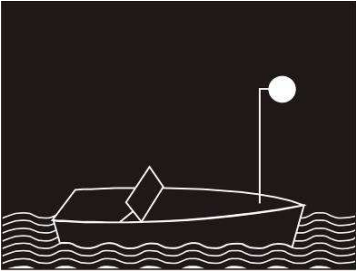
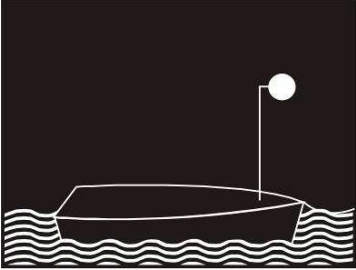
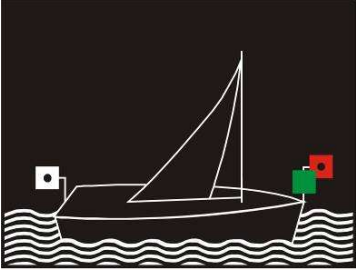
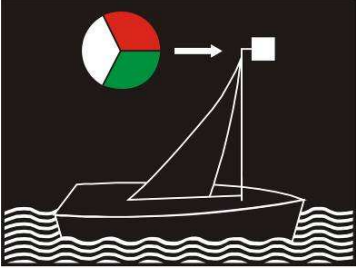
Night	Sketch	Day
	<p><b>25</b></p>	
<p>Article 3.13, paragraph 2: Motorized small craft less than 7 m long proceeding alone.</p>		
	<p><b>26</b></p>	
<p>Article 3.13, paragraph 4: Small craft towed or propelled in side-by-side formation.</p>		
	<p><b>27</b></p>	
<p>Article 3.13, paragraph 5: Small sailing craft.</p>		
	<p><b>28</b></p>	
<p>Article 3.13, paragraph 2: Motorized small craft less than 7 m long proceeding alone.</p>		

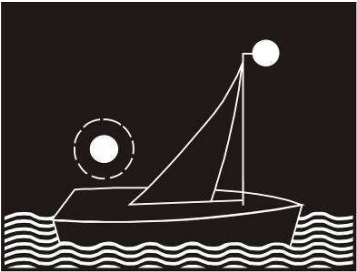
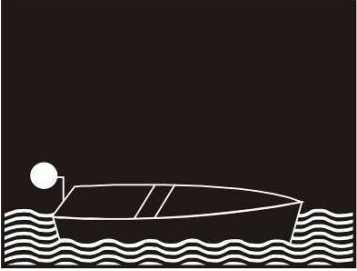
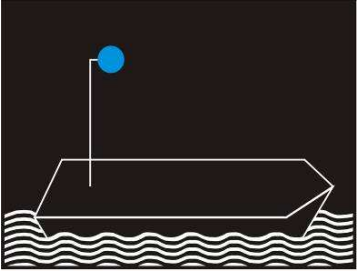
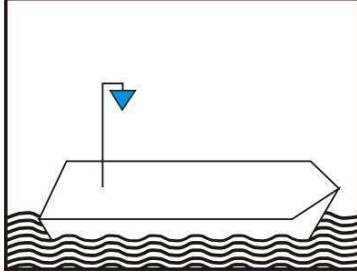
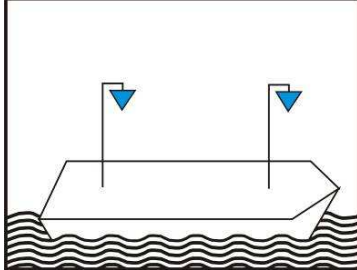
Night	Sketch	Day
	<p><b>29</b></p>	
<p>Article 3.13, paragraph 5: Small sailing craft less than 7 m long carrying a white light visible from all directions, and on the approach of other vessels displaying a second ordinary white light.</p>		
	<p><b>30</b></p>	
<p>Article 3.13, paragraph 6: Small craft proceeding alone, neither motorized nor under sail.</p>		
	<p><b>31a</b></p>	
	<p><b>31b</b></p>	
<p>Article 3.14, paragraph 1: Additional marking for vessels carrying out certain transport operations involving dangerous substances: flammable substances that are referred to in accordance with the requirements of sub-section 7.1.5.0 or sub-section 7.2.5.0 of ADN and Chapter 3.2, Table A, column (12) or Table C column (19) of AND.</p>		

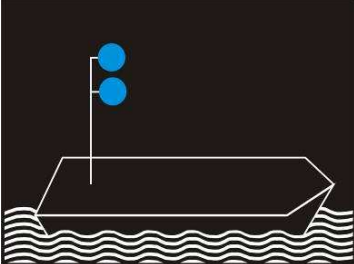
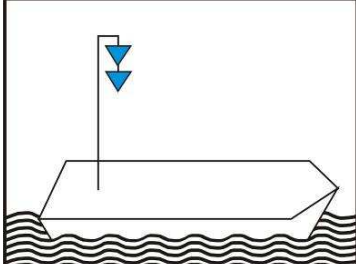
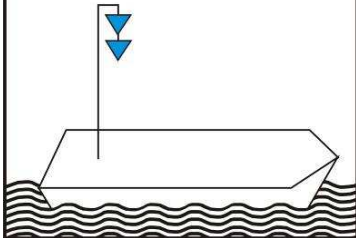
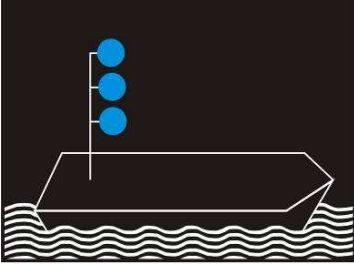
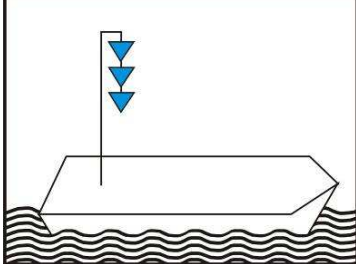
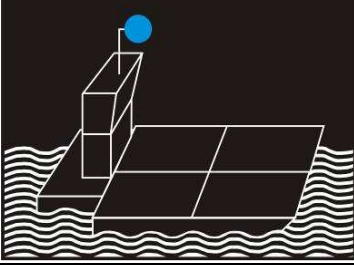
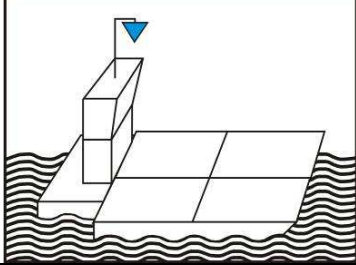
Night	Sketch	Day
	<p><b>32a</b></p>	
	<p><b>32b</b></p>	
<p>Article 3.14, paragraph 2: Additional marking for vessels carrying out certain transport operations involving dangerous substances: substances constituting health hazards in accordance with the requirements of sub-section 7.1.5.0 or sub-section 7.2.5.0 of ADN and Chapter 3.2, Table A, column (12) or Table C column (19) of ADN.</p>		
	<p><b>33</b></p>	
<p>Article 3.14, paragraph 3: Additional marking of vessels carrying out certain transport operations involving dangerous substances: explosives in accordance with the requirements of sub-section 7.1.5.0 or sub-section 7.2.5.0 of ADN and Chapter 3.2, Table A, column (12) of ADN.</p>		
	<p><b>34</b></p>	
<p>Article 3.14, paragraph 4: Additional marking of pushed convoys carrying out certain transport operations involving dangerous substances in accordance with the requirements of sub-section 7.1.5.0 or sub-section 7.2.5.0 of ADN and Chapter 3.2, Table A, column (12) or table C column (19) of ADN.</p>		

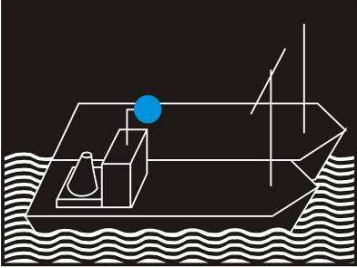
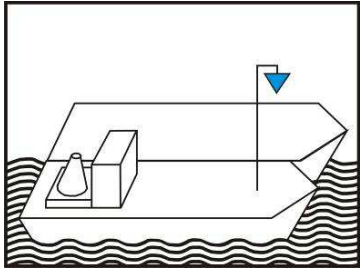
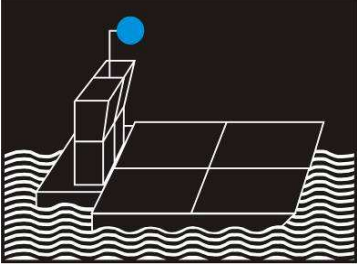
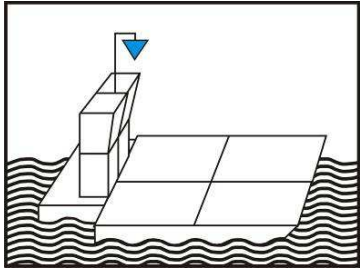
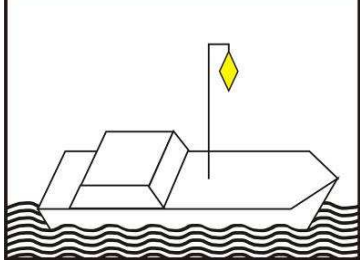
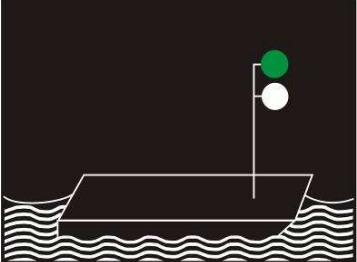
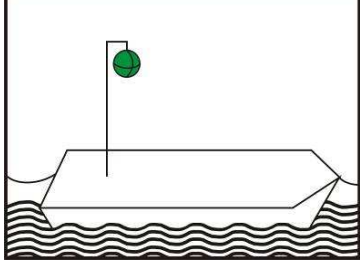
Night	Sketch	Day
	<b>35</b>	
<p>Article 3.14, paragraph 4: Additional marking of side-by-side formations carrying out certain transport operations involving dangerous substances in accordance with the requirements of sub-section 7.1.5.0 or sub-section 7.2.5.0 of ADN and Chapter 3.2, Table A, column (12) or Table C column (19) of ADN.</p>		
	<b>36</b>	
<p>Article 3.14, paragraph 5: Additional marking of pushed convoys propelled by two pushers placed side by side and carrying out certain transport operations involving dangerous substances in accordance with the requirements of sub-section 7.1.5.0 or sub-section 7.2.5.0 of ADN and Chapter 3.2, Table A, column (12) or Table C column (19) of ADN.</p>		
	<b>37</b>	
<p>Article 3.15: Vessels authorized to carry more than 12 passengers with a hull length of less than 20 m.</p>		
	<b>38</b>	
<p>Article 3.16, paragraph 1: Ferry-boats not moving independently.</p>		

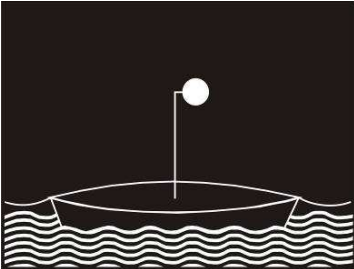
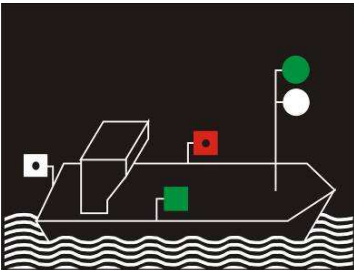
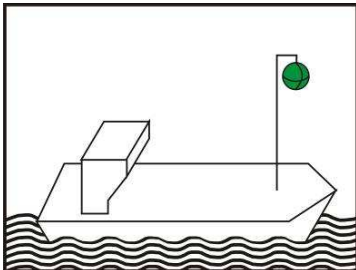
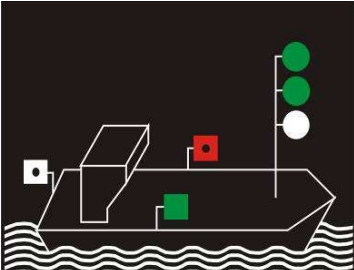
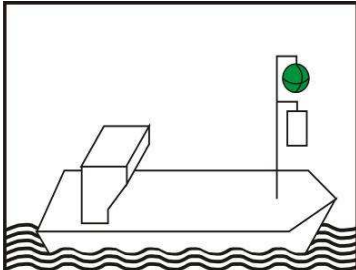
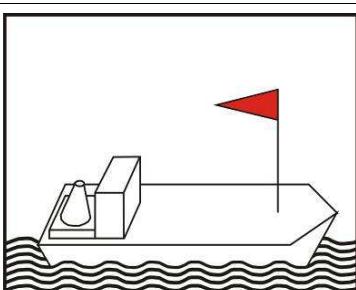
Night	Sketch	Day
	<p style="text-align: center;"><b>39</b></p>	
<p>Article 3.16, paragraph 2: Leading boat or float of a longitudinal-cable ferry-boat.</p>		
	<p style="text-align: center;"><b>40</b></p>	
<p>Article 3.16, paragraph 3: Ferry-boats moving independently.</p>		
	<p style="text-align: center;"><b>41</b></p>	
<p>Article 3.16, paragraph 4: Ferry-boats moving independently and enjoying priority.</p>		
	<p style="text-align: center;"><b>42</b></p>	
<p>Article 3.17: Vessels having priority of passage.</p>		

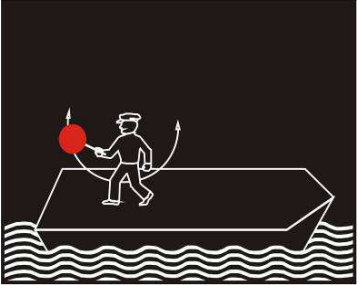
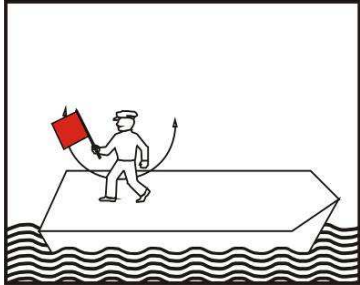
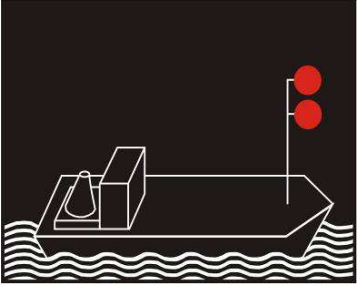
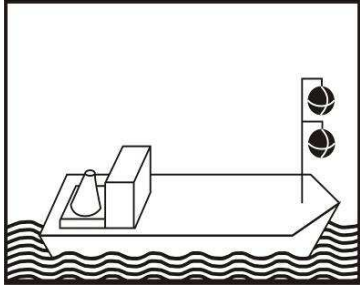
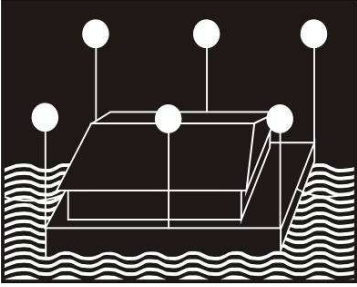

Night	Sketch	Day
	<p>43a</p>	
	<p>43b</p>	
<p>Article 3.18, paragraph 1: Additional marking for vessels unable to manoeuvre.</p>		
	<p>44</p>	
<p>Article 3.19: Assemblies of floating material and floating establishments under way.</p>		

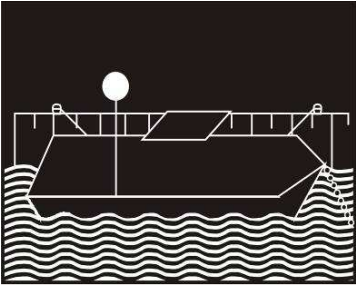
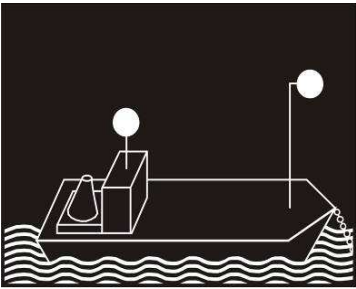
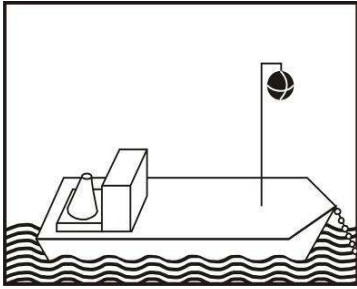
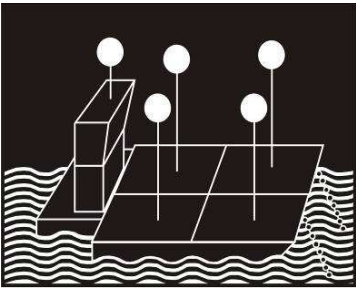
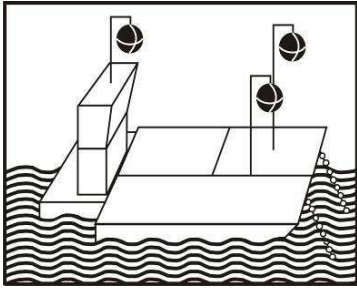
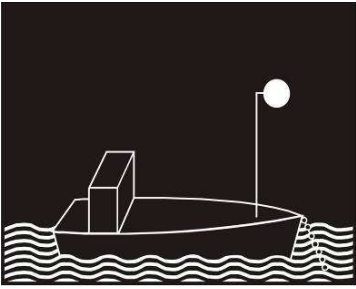
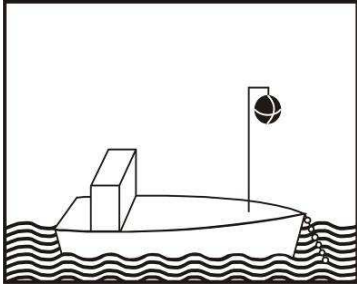

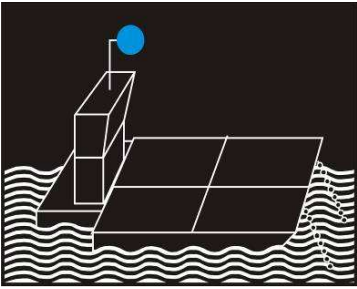
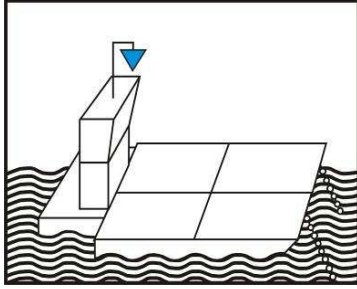
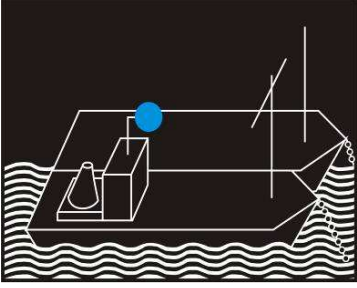
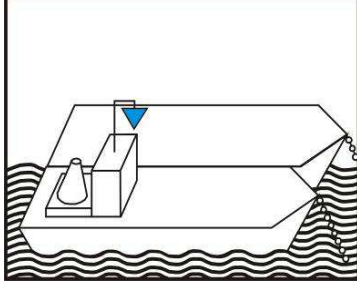
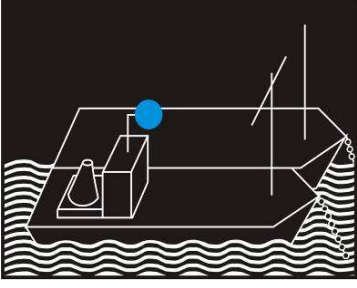
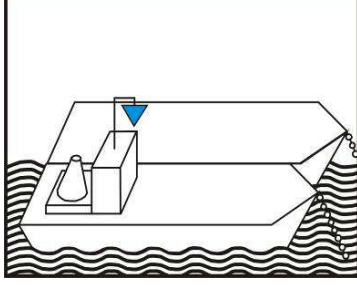
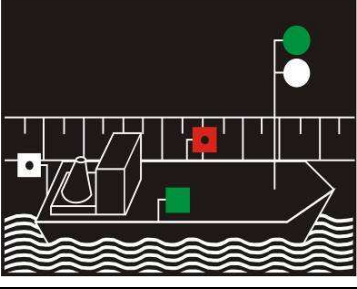

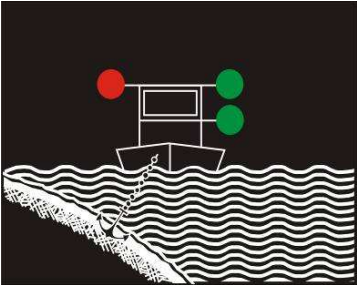
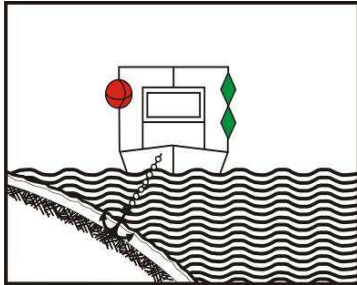
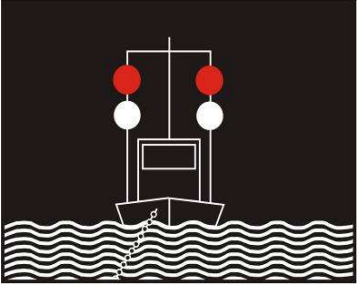
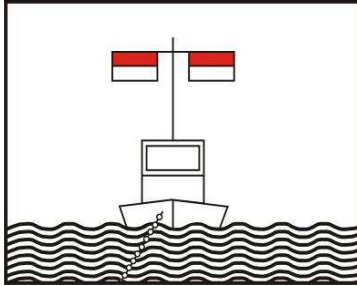
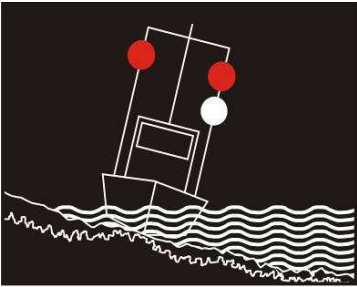
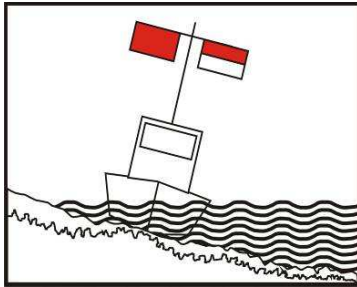
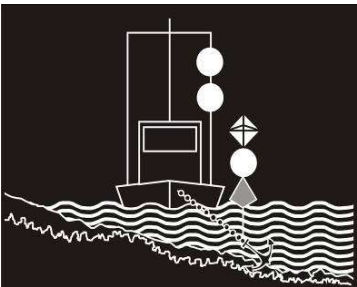
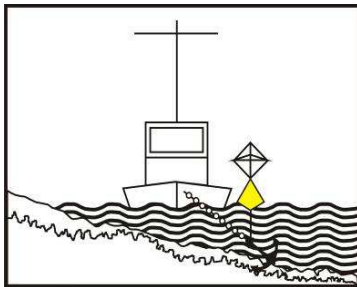

<b>3. MARKING WHEN STATIONARY</b>		
<b>Night</b>	<b>Sketch</b>	<b>Day</b>
	<b>45</b>	
Article 3.20, paragraphs 1 and 4: Vessels directly or indirectly made fast to the bank.		
	<b>46</b>	
Article 3.20, paragraph 2: Vessels stationary offshore.		
	<b>47</b>	
Article 3.20, paragraph 3: Pushed convoys stationary offshore.		
	<b>48</b>	
Article 3.20, paragraph 4: Stationary small craft.		

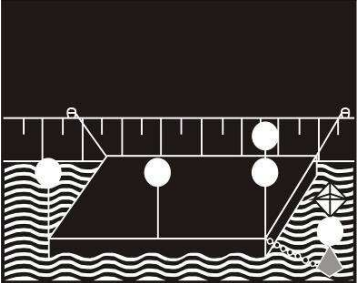
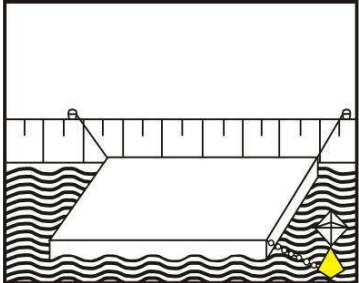
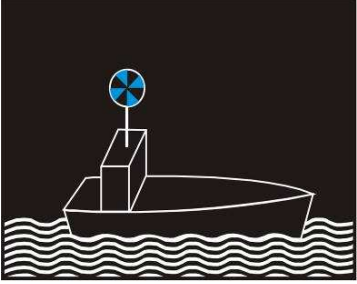
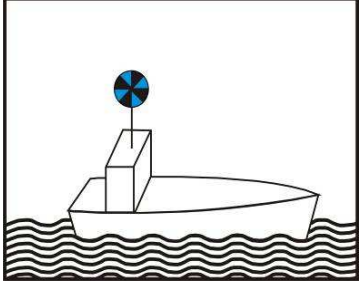
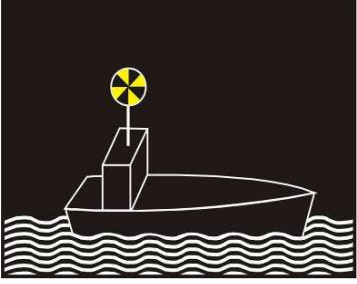
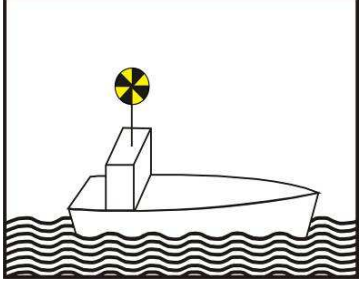
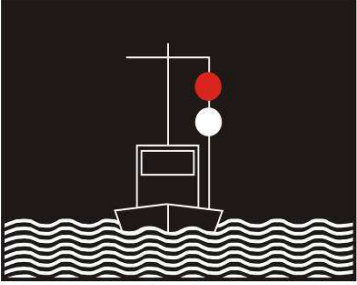
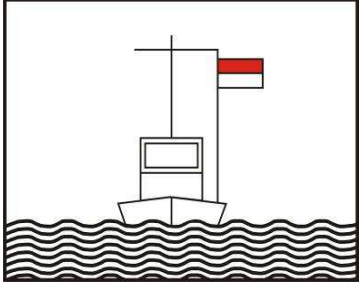
Night	Sketch	Day
	<p>49</p>	
<p>Article 3.21: Additional marking for stationary vessels carrying out certain transport operations involving dangerous substances.</p>		
	<p>50</p>	
<p>Article 3.21: Additional marking for stationary pushed convoys carrying out certain transport operations involving dangerous substances.</p>		
	<p>51</p>	
<p>Article 3.21: Additional marking for stationary side-by-side formations carrying out certain transport operations involving dangerous substances.</p>		
	<p>52</p>	
<p>Article 3.22, paragraph 1: Ferry-boats not moving independently when made fast at their landing stage.</p>		
<p><b>Night</b></p>	<p><b>Sketch</b></p>	<p><b>Day</b></p>

	<p><b>53</b></p>	
<p>Article 3.22, paragraph 2: Ferry-boats moving independently, but made fast at their landing stage.</p>		
	<p><b>54</b></p>	
<p>Article 3.23: Assemblies of floating material and floating establishments when stationary.</p>		
	<p><b>55</b></p>	
<p>Article 3.24: Stationary vessels engaged in fishing with nets or poles.</p>		
	<p><b>56</b></p>	
<p>Article 3.25, paragraph 1, letter a: Floating equipment at work and vessels carrying out work or sounding or measuring operations; channel clear on both sides.</p>		

Night	Sketch	Day
	<p>57</p>	
<p>Article 3.25, paragraph 1, letters a and b: Floating equipment at work and vessels carrying out work or sounding or measuring operations; channel clear on one side.</p>		
	<p>58</p>	
<p>Article 3.25, paragraph 1, letter c: Floating equipment at work and vessels carrying out work or sounding or measuring operations and grounded or sunken vessels; protection against wash; channel clear on both sides.</p>		
	<p>59</p>	
<p>Article 3.25, paragraph 1, letters c and d: Floating equipment at work and vessels carrying out work or sounding or measuring operations and grounded or sunken vessels; protection against wash; channel clear on one side.</p>		
	<p>60</p>	
<p>Article 3.26: Vessels whose anchors may be a danger to navigation.</p>		

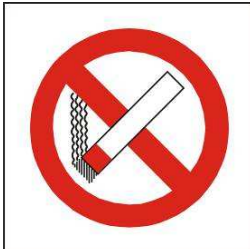
Night	Sketch	Day
	<p><b>61</b></p>	
<p>Article 3.26: Assemblies of floating material or floating establishments whose anchors may be a danger to navigation.</p>		
<p><b>4. SPECIAL MARKING</b></p>		
	<p><b>62</b></p>	
<p>Article 3.27: Additional marking for vessels of the supervisory authorities and fire-fighting and rescue services.</p>		
	<p><b>63</b></p>	
<p>Article 3.28: Additional marking for vessels under way carrying out work in the waterway.</p>		
	<p><b>64</b></p>	
<p>Article 3.29: Additional marking for protection against wash.</p>		

Night	Sketch	Day
	<p>65</p>	
<p>Article 3.30: Distress signals.</p>		
	<p>66</p>	
<p>Article 3.31: Boarding prohibited.</p>		
	<p>67</p>	
<p>Article 3.32: Prohibition of smoking or using an unprotected light or flame.</p>		
	<p>68</p>	
<p>Article 3.33: Lateral berthing prohibited.</p>		

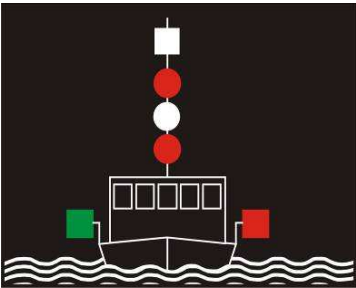
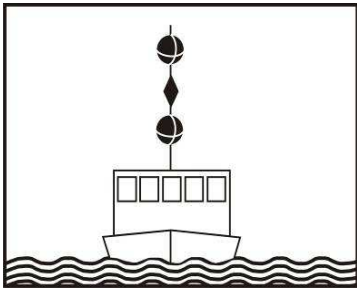
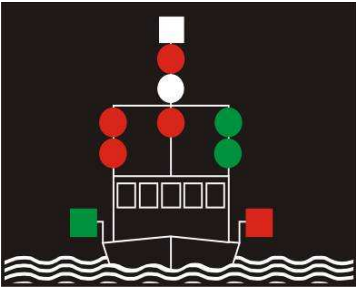
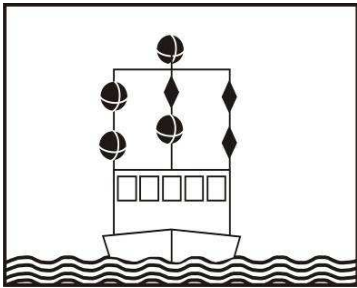
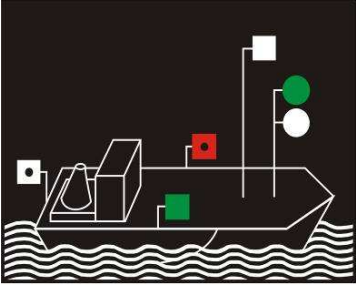
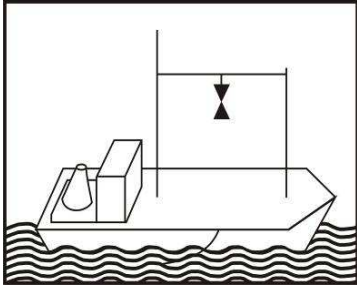
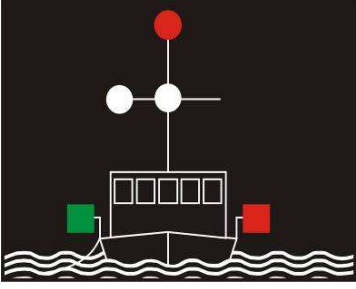
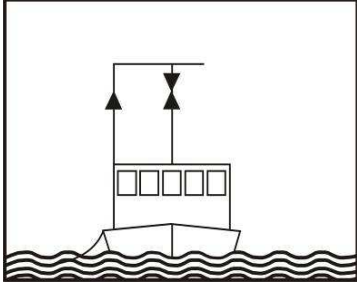
Night	Sketch	Day
	<p>69</p>	
<p>Article 3.34, paragraph 1: Additional marking for vessels whose ability to manoeuvre is limited.</p>		
	<p>70</p>	
<p>Article 3.34, paragraph 2: Additional marking for vessels whose ability to manoeuvre is limited; channel clear on one side.</p>		
	<p>71</p>	
<p>Article 3.35, paragraph 1: Additional marking for vessels engaged in drawing a trawl or other fishing gear through the water (trawler).</p>		
	<p>72</p>	
<p>Article 3.35, paragraph 2: Fishing vessels other than trawlers if the fishing tackle extends more than 150 m horizontally from the vessel.</p>		

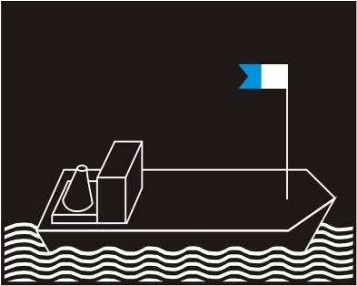
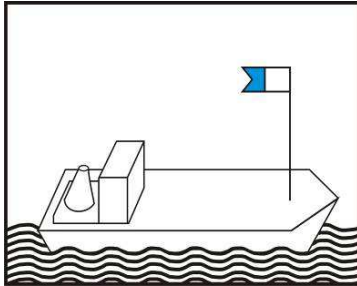
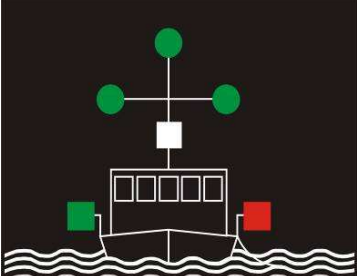
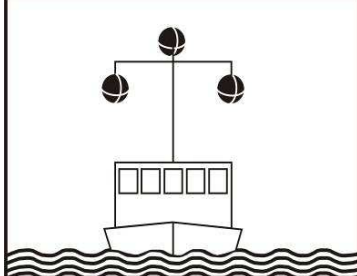
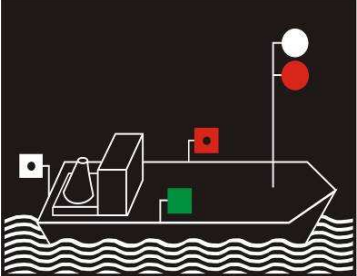
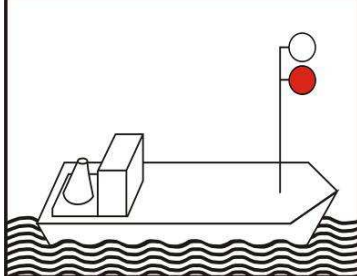

Night	Sketch	Day
	<p><b>73</b></p>	
<p>Article 3.36: Additional marking for vessels used for underwater diving.</p>		
	<p><b>74</b></p>	
<p>Article 3.37: Additional marking for vessels engaged in minesweeping.</p>		
	<p><b>75</b></p>	
<p>Article 3.38: Additional marking for vessels on pilotage service.</p>		

**Annex 4**

**LIGHTS AND THE COLOUR**

**OF SIGNAL LIGHTS ON VESSELS**

**(Left void)<sup>1</sup>**

---

<sup>1</sup> Requirements to lights and the colour of signal lights on vessels shall be included in "Recommendations on Harmonized Europe-Wide Technical Requirements for Inland Navigation Vessels" (Resolution No. 61).

**Annex 5**  
**INTENSITY AND RANGE**  
**OF SIGNAL LIGHTS ON VESSELS**

**(Left void)<sup>2</sup>**

---

<sup>2</sup> Requirements to intensity and range of signal lights on vessels shall be included in "Recommendations on Harmonized Europe-Wide Technical Requirements for Inland Navigation Vessels" (Resolution No. 61).

## Annex 6

# SOUND SIGNALS

### I. SOUND INTENSITY OF SIGNALS

Mechanically-operated sound signalling devices used by inland waterway vessels shall be capable of producing sound signals with the following characteristics:

#### 1. *Frequency*

- (a) For motorized vessels other than the small craft referred to in paragraph (b), the fundamental frequency shall be 200 Hz, with a tolerance of  $\pm 20\%$ ;
- (b) For non-motorized vessels and small craft the fundamental frequency shall be above 350 Hz;
- (c) For the three-tone signals used by vessels navigating by radar under conditions of reduced visibility, the fundamental frequencies of the tones shall be between 165 and 297 Hz, with an interval of at least two full tones between the highest-pitched and the lowest-pitched sound.

#### 2. *Sound pressure level*

The sound pressure levels given below shall be measured at, or referred to, a point 1 metre in front of the centre of the opening of the horn, the measurement being made, as far as possible, away from any sound reflecting surfaces.

- (a) For motorized vessels other than the small craft referred to in paragraph (b), the weighted sound pressure level shall be between 120 and 140 dB (A);
- (b) For non-motorized vessels and small craft which are not equipped or used to tow vessels other than small craft, the weighted sound pressure level shall be between 100 and 125 dB (A);
- (c) For the three-tone signals used by vessels navigating by radar under conditions of reduced visibility, the weighted sound pressure level of each tone shall be between 120 and 140 dB (A).

## **II. MONITORING OF SOUND PRESSURE LEVEL**

The sound pressure level shall be checked by the competent authorities by means of the sonometer standardized by the International Electrotechnical Commission (reference IEC.179) or by means of the ordinary sonometer standardized by IEC (reference IEC.123).









## **III. SOUND SIGNALS TO BE USED BY VESSELS**

Sound signals other than the ringing of a bell and the three-tone signal shall consist in the emission of one blast or of several successive blasts having the following characteristics:

- short blast: a blast lasting about one second;
- long blast: a blast lasting about four seconds.

The interval between two successive blasts shall be about one second except for the signal "series of very short blasts" which shall comprise a series of not less than six blasts, each lasting about a quarter of a second, separated by a silence of the same duration.

A. *General signals*

	1 long blast	"Caution"	
	1 short blast	"I am altering my course to starboard"	
	2 short blasts	"I am altering my course to port"	
	3 short blasts	"I am going astern"	
	4 short blasts	"I am unable to manoeuvre"	
	Repeated, 1 short and 1 long blasts	"Do not approach" *	
	Series of very short blasts	"Imminent danger of collision"	
	Repeated long blasts	"Distress signal"	Article 4.04
	Peals of a bell		

\* This signal has a different meaning on the internal waterways of the Russian Federation.

Informal document SC.3 No. 2 (2009)Rev.1

B. *Meeting signals*

*First case*





■	1 short blast by vessel proceeding upstream	"I wish to pass on the port side"	Article 6.04, paragraph 5
■	1 short blast by vessel proceeding downstream	"Agreed; pass on the port side"	Article 6.04, paragraph 6
■ ■	2 short blasts by vessel proceeding downstream	"No; pass on the starboard side"	Article 6.05, paragraph 3
■ ■	2 short blasts by vessel proceeding upstream	"Agreed; I will pass on the starboard side"	Article 6.05, paragraph 4

*Second case*





■ ■	2 short blasts by vessel proceeding upstream	"I wish to pass on the starboard side"	Article 6.04, paragraph 5
■ ■	2 short blasts by vessel proceeding downstream	"Agreed; pass on the starboard side"	Article 6.04, paragraph 6
■	1 short blast by vessel proceeding downstream	"No; pass on the port side"	Article 6.05, paragraph 3
■	1 short blast by vessel proceeding upstream	"Agreed; I will pass on the port side"	Article 6.05, paragraph 4

C. *Overtaking signals*

*First case*

	2 long blasts followed by 2 short blasts, by overtaking vessel	"I wish to overtake on your port side"	Article 6.10, paragraph 2
	1 short blast by vessel to be overtaken	"Agreed; overtake on my starboard side"	Article 6.10, paragraph 3
	2 short blasts by vessel to be overtaken	"No; overtake on my starboard side"	Article 6.10, paragraph 4
	1 short blast by overtaking vessel	"Agreed; I will pass on your starboard side"	Article 6.10, paragraph 4

*Second case*

	2 long blasts followed by 1 short blast by overtaking vessel	"I wish to pass on your starboard side"	Article 6.10, paragraph 2
	2 short blasts by vessel to be overtaken	"Agreed; overtake on my starboard side"	Article 6.10, paragraph 3
	1 short blast by vessel to be overtaken	"No; overtaken on my port side"	Article 6.10, paragraph 4
	2 short blasts by overtaking vessel	"Agreed; I will overtake on your port side"	Article 6.10, paragraph 4

*Overtaking impossible*

	5 short blasts by vessel to be overtaken	"I cannot be overtaken"	Article 6.10, paragraph 5
---	--	-------------------------	---------------------------



Informal document SC.3 No. 2 (2009)Rev.1

D. *Turning signals*



1 long blast followed by  
1 short blast

"I am going to turn to  
starboard"

Article 6.13,  
paragraph 2



1 long blast followed by  
2 short blasts

"I am going to turn to  
port"

Article 6.13,  
paragraph 2

E. *Harbours and tributary waterways: entering and leaving, followed by crossing the waterway*

E.1 *Signals on entering and leaving harbours and tributary waterways*



3 long blasts followed by  
1 short blast

"I am going to starboard"

Article 6.16,  
paragraph 2



3 long blasts followed by  
2 short blasts

"I am going to port"

Article 6.16,  
paragraph 2

E.2 *Signals on crossing after entering the waterway*



3 long blasts

"I am going to cross"

Article 6.16,  
paragraph 2

followed if necessary by:



1 long blast followed by  
1 short blast

"I am going to starboard"

Article 6.16,  
paragraph 2



1 long blast followed by  
2 short blasts

"I am going to port"

Article 6.16,  
paragraph 2

F. *Signals in reduced visibility*

(a) *Vessels navigating by radar*

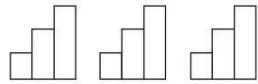

(i) Vessels, other than small craft, proceeding downstream

Three-tone signal repeated as often as necessary

Article 6.32, paragraph 4 (a)



(ii) Single vessel proceeding upstream

1 long blast

Article 6.32, paragraph 4 (c)

(b) *Vessels not navigating by radar*



(i) Any vessel proceeding alone

1 long blast repeated at least once a minute

Article 6.33, paragraph 1 (b)

(c) *Stationary vessels*



1 peal of a bell, repeated at least once a minute

"I am lying on left side of channel"

Article 6.31, paragraph 1 (a)



2 peals of a bell, repeated at least once a minute

"I am lying on right side of channel"

Article 6.31, paragraph 1 (b)



3 peals of a bell, repeated at least once a minute

"I am stationary, position uncertain"

Article 6.31, paragraph 1 (c)

**Annex 7**

**WATERWAY SIGNS AND MARKING**<sup>3</sup>

---

<sup>3</sup> Waterway signs and marking in the Russian Federation and Ukraine correspond to national rules.

**Annex 7**

**WATERWAY SIGNS AND MARKING <sup>1</sup>**

(1) The main signs given in section I below may be supplemented or clarified by auxiliary signs given in section II.

(2) Boards may be surrounded by a thin white line.

Section I. MAIN SIGNS

A. PROHIBITORY SIGNS

A.1 No entry (general sign)  
(see articles 6.08, 6.16, 6.22, 6.22 *bis*, 6.25, 6.26, 6.27 and 6.28 *bis*)

A.1a boards



A.1b, A.1c and A.1d  
or red lights

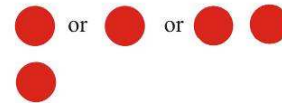

Two boards, two lights or two flags,  
one above the other, indicate a  
prolonged prohibition

A.1e and A.1f  
or red flags

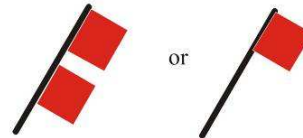

A.2 No overtaking  
(see article 6.11)

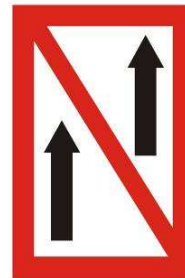

A.3 No overtaking of convoys by convoys  
(see article 6.11)

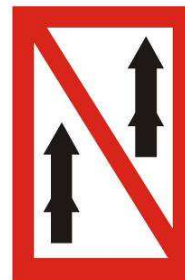

<sup>1</sup> Waterway signs and marking in the Russian Federation and Ukraine correspond to national rules.

A.4 No passing or overtaking  
(see article 6.08)



A.4.1 No passing or overtaking of convoys by convoys  
(See article 6.08)



A.5 No berthing  
(i.e. no anchoring or making fast to the bank)  
(see article 7.02)















A.5.1 No berthing within the breadth indicated in metres  
(measured from the sign)  
(see article 7.02)



A.6 No anchoring or trailing of anchors, cables or chains  
(see articles 6.18 and 7.03)



<p>A.7 No making fast to the bank (see article 7.04)</p>	
<p>A.8 No turning (see article 6.13)</p>	
<p>A.9 Do not create wash (see article 6.20)</p>	
<p>A.9a</p>	
<p>A.9b</p>	
<p>A.10 No passing outside the area marked (in openings of bridges or weirs) (see article 6.24)</p>	
<p>A.11 Entry prohibited, but prepare to get under way (see articles 6.26 and 6.28 bis)</p>	<p>A.11a   or A.11b  </p> <p>or A.11c (red light extinguished)  </p>

A.12 Motorized craft prohibited



A.13 All sports or pleasure craft prohibited<sup>1</sup>



A.14 Water skiing prohibited



A.15 Sailing vessels prohibited



A.16 All craft other than motorized vessels or sailing craft prohibited



<sup>1</sup> The competent authorities may also use this board to prohibit small craft.

A.17 Use of sailboards prohibited



A.18 End of zone authorized for high speed navigation of small sport and pleasure craft



A.19 No launching or beaching of vessels



A.20 Water bikes prohibited





B. MANDATORY SIGNS

B.1 Proceed in the direction shown by the arrow  
(see article 6.12)

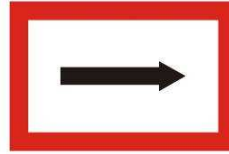

B.2

B.2a Move to the side of the channel  
on your port side  
(see article 6.12)



B.2b Move to the side of the channel  
on your starboard side  
(see article 6.12)



B.3

B.3a Keep to the side of the channel  
on your port side  
(see article 6.12)

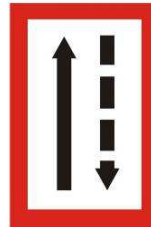

B.3b Keep to the side of the channel  
on your starboard side  
(see article 6.12)



B.4

B.4a Cross channel to port  
(see article 6.12)



B.4b Cross channel to starboard  
(see article 6.12)



B.5 Stop as prescribed in the Regulations  
(see articles 6.26 and 6.28)



B.6 Do not exceed the speed indicated  
(in km/h)



B.7 Give a sound signal

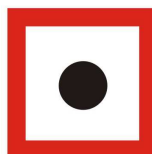

B.8 Keep a particularly sharp lookout  
(see article 6.08)

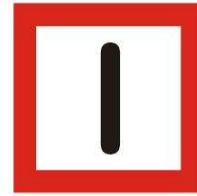

B.9 Do not enter or cross the main  
waterway until certain that this  
will not oblige vessels proceeding  
on it to change their course or speed  
(see article 6.16)

B.9a



B.9b

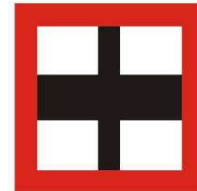

B.10 Vessels proceeding on the main waterway must,  
if necessary, change course and speed to allow  
vessels to leave harbours or tributary waterways  
(see article 6.16)



B.11 Obligation to enter into a radiotelephone link  
(see article 4.04, paragraph 4)

B.11a



Obligation to enter into a radiotelephone  
link on the channel as indicated on the board  
(see article 4.04, paragraph 4)

B.11b



C. RESTRICTIVE SIGNS

C.1 Depth of water limited



C.1a



C.1b

C.2 Headroom limited

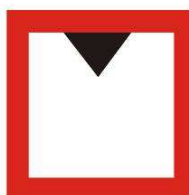

C.2a



C.2b

C.3 Width of passage or channel limited

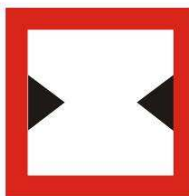

C.3a



C.3b

*Note:* Boards C.1, C.2 and C.3 may carry, in addition, figures indicating in metres the depth of water, the headroom and the width of passage or the channel respectively.

C.4 There are restrictions on navigation: make enquiries

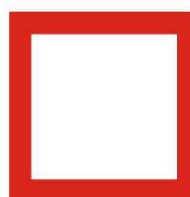

C.5 The channel lies at a distance from the right (left) bank; the figure shown on the sign indicates the distance in metres, measured from the sign, to which vessels should keep



D. RECOMMENDATORY SIGNS

D.1 Recommended channel

- (a) In both directions  
(see articles 6.25, 6.26 and 6.27)

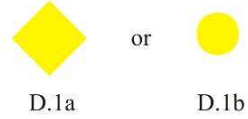

- (b) Only in the direction indicated  
(passage in the opposite direction prohibited)  
(see articles 6.25, 6.26 and 6.27)

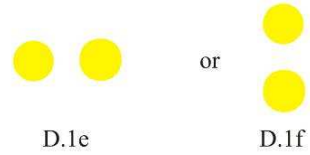
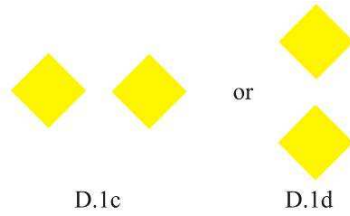

- D.2 You are recommended to keep  
within the area indicated  
(in openings of bridges or weirs)  
(see article 6.24)

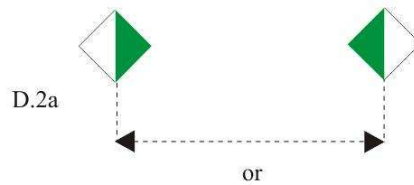

- D.3 You are recommended to proceed:

In the direction shown by the arrow

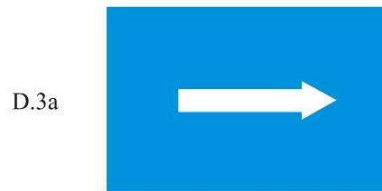

In the direction from the fixed light  
towards the isophase light



E. INFORMATIVE SIGNS

E.1 Entry permitted (general sign)  
(see articles 6.08, 6.16, 6.26,  
6.27 and 6.28 *bis*)

E.1a



or

E.1b, E.1c  
and E.1d

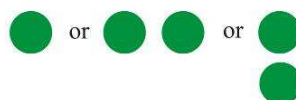

E.2 Overhead cable crossing

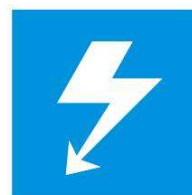

E.3 Weir

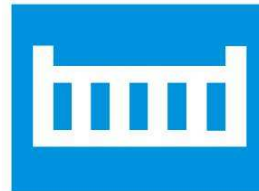

E.4

(a) Ferry-boat not moving independently

E.4a



(b) Ferry-boat moving independently

E.4b

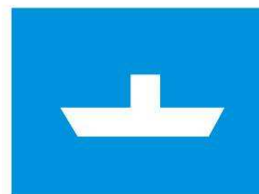

E.5 Berthing (i.e. anchoring or making fast to the bank) permitted (see articles 7.02 and 7.05)



E.5.1 Berthing permitted on the stretch of water of the breadth measured from, and shown on the board in metres (see article 7.05)



E.5.2 Berthing permitted on the stretch of water bounded by the two distances measured from, and shown on the board in metres (see article 7.05)



E.5.3 Maximum number of vessels permitted to berth abreast (see article 7.05)



E.5.4 Berthing area reserved for pushing-navigation vessels that are not required to carry the marking prescribed in article 3.14 (see article 7.06)

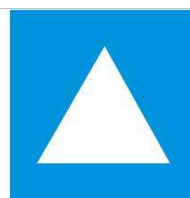

E.5.5 Berthing area reserved for pushing-navigation vessels that are required to carry one blue light or one blue cone under article 3.14, paragraph 1 (see article 7.06)

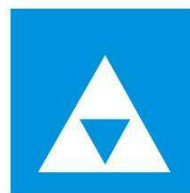

E.5.6 Berthing area reserved for pushing-navigation vessels that are required to carry two blue lights or two blue cones under article 3.14, paragraph 2 (see article 7.06)



E.5.7 Berthing area reserved for pushing-navigation vessels that are required to carry three blue lights or three blue cones under article 3.14, paragraph 3 (see article 7.06)



E.5.8 Berthing area reserved for vessels other than pushing-navigation vessels that are not required to carry the marking prescribed in article 3.14 (see article 7.06)

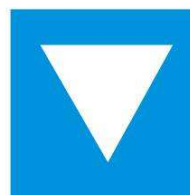





E.5.9 Berthing area reserved for vessels other than pushing-navigation vessels that are required to carry one blue light or one blue cone under article 3.14, paragraph 1 (see article 7.06)



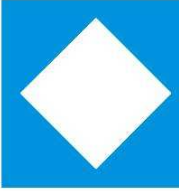
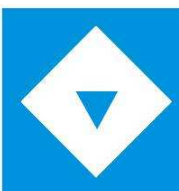
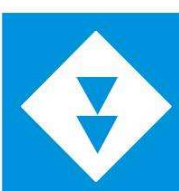

---

E.5.10	Berthing area reserved for vessels other than pushing-navigation vessels that are required to carry two blue lights or two blue cones under article 3.14, paragraph 2 (see article 7.06)	
E.5.11	Berthing area reserved for vessels other than pushing-navigation vessels that are required to carry three blue lights or three blue cones under article 3.14, paragraph 3 (see article 7.06)	
E.5.12	Berthing area reserved for all vessels that are not required to carry the marking prescribed in article 3.14 (see article 7.06)	
E.5.13	Berthing area reserved for all vessels that are required to carry one blue light or one blue cone under article 3.14, paragraph 1 (see article 7.06)	
E.5.14	Berthing area reserved for all vessels that are required to carry two blue lights or two blue cones under article 3.14, paragraph 2 (see article 7.06)	
E.5.15	Berthing area reserved for all vessels that are required to carry three blue lights or three blue cones under article 3.14, paragraph 3 (see article 7.06)	

E.6 Anchoring (see article 7.03) or trailing of anchors, cables or chains permitted (see article 6.18)



E.7 Making fast to the bank permitted (see article 7.04)



E.7.1 Berthing area reserved for loading and unloading vehicles. (Maximum duration of berthing permitted may be added on an information plate below the board)



E.8 Turning area (see articles 6.13, 7.02)

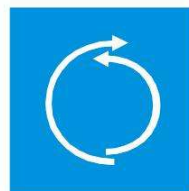





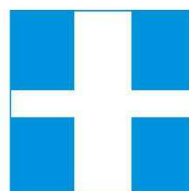



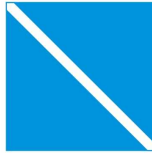

E.9 The waterways being approached are considered to be tributaries of this waterway (see article 6.16)

E.9a



E.9b



- E.10 This waterway is considered to be a tributary of the waterway being approached (see article 6.16)
- E.10a 
- E.10b 
- E.11 End of a prohibition or obligation applying to traffic in one direction only, or end of a restriction
- E.11a 
- or
- E.11b 
- E.12 Advance signals: one or two white lights
- (a) Fixed light(s): Difficulty ahead - stop if the regulations so require
- E.12a  or E.12b 
- (b) Isophase light(s): You may proceed
- E.12c  or E.12d 
- E.13 Drinking-water supply
- 
- E.14 Telephone
- 

E.15 Motorized vessels permitted

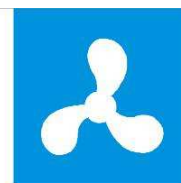

E.16 Sports or pleasure craft permitted<sup>1</sup>



E.17 Water skiing permitted



E.18 Sailing vessels permitted



E.19 Craft other than motorized vessels or sailing craft permitted



E.20 Use of sailboards permitted



<sup>1</sup> The competent authorities may also use this board to permit small craft.



E.21 Zone authorized for high speed navigation of small sport and pleasure craft



E.22 Launching or beaching of vessels permitted



E. 23 Possibility of obtaining nautical information by radio-telephone on the channel indicated



E.24 Water bikes permitted



Section II. AUXILIARY SIGNS

The main signs (see section I) may be supplemented by the following auxiliary signs:

1. *Panels showing the distance at which the regulation applies or the special feature indicated by the main sign is to be found*

*Note:* The panels are placed above the main sign.

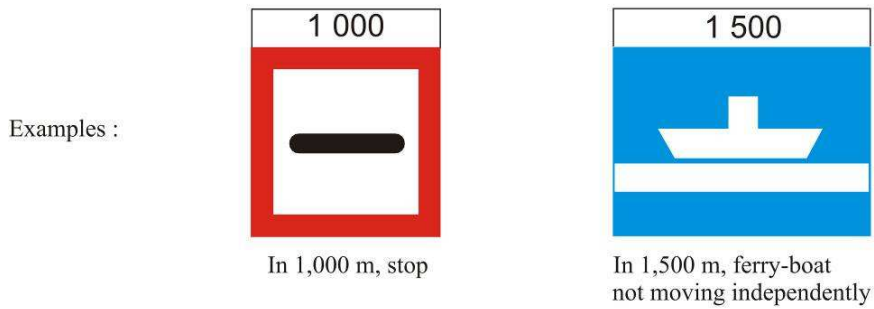

2. *Additional luminous signal*

Luminous white arrow combined with certain lights, with the following meanings:

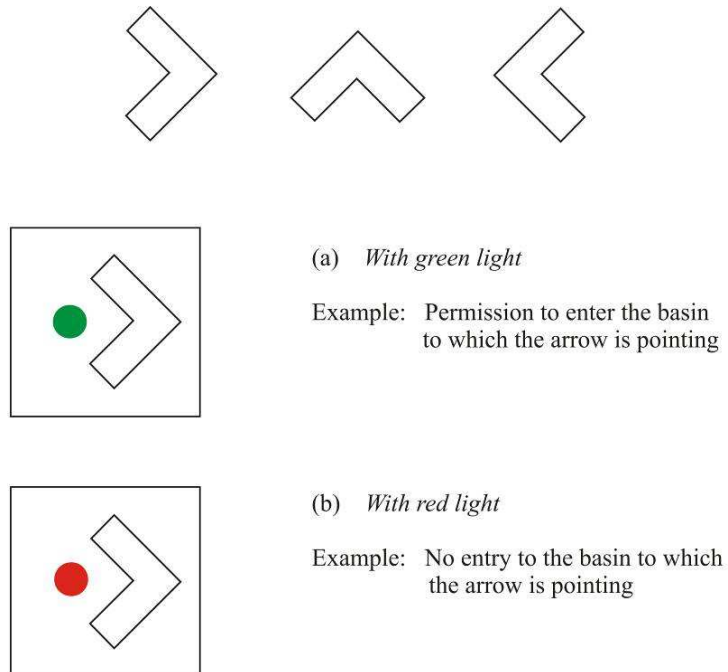

3. *Pointers showing the direction of the section to which the main sign applies*

*Note:* The pointers need not necessarily be white and may be placed beside or below the main sign.

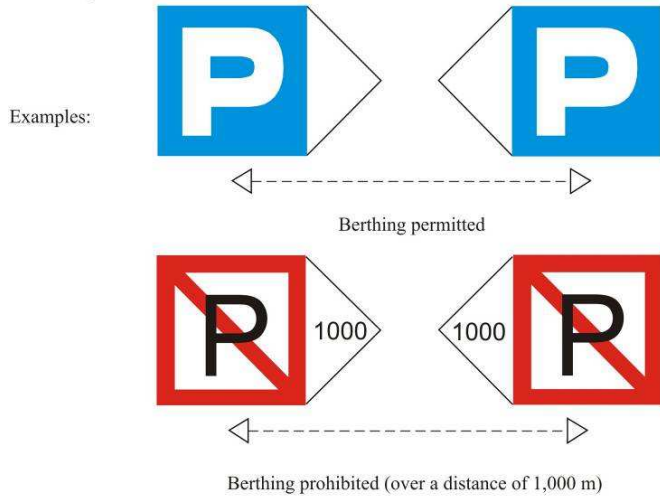

4. *Panels giving explanations or additional information*

*Note:* These panels are placed below the main sign.

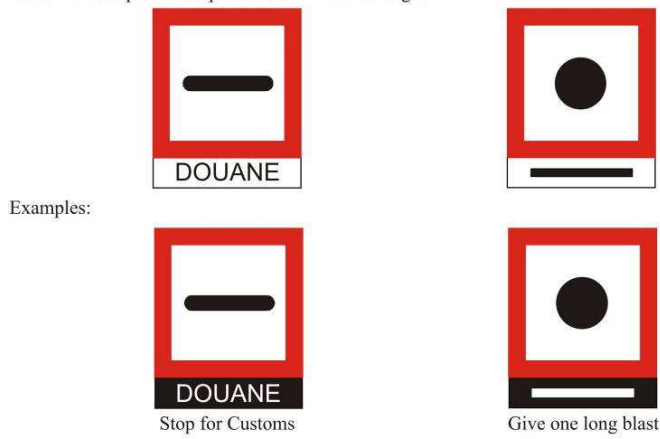



**Annex 8**

**BUOYAGE AND MARKING OF WATERWAYS,  
LAKES AND BROAD WATERWAYS**

**I. GENERAL**

1. Marking

The waterway, the fairway, as well as the danger points and obstacles are not always marked.

Buyos, when used, shall be anchored at approximately 5 m distance from the limits that they indicate.

Groynes and shallows can be marked using fixed marks or buyos. These marks or buyos shall, usually, be placed on the borders of groynes and shallows or in front of them.

It is necessary to keep a sufficient distance from the marks and the buyos to avoid the risk of getting on the ground or hitting an obstacle.

2. Definitions

Right-hand side/left-hand side: the designations "right-hand side" and "left-hand side" of the waterway or channel are to be understood as for an observer facing downstream;

on canals, lakes and broad waterways, the terms "right" and "left" shall be defined by the authorities.

Light: a distinctive light used as a marking.

Fixed light: an uninterrupted light of constant intensity and colour.

Rhythmic light: a light of constant intensity and colour operating in a characteristic and regularly repeated succession of spells of illumination and extinction.

3. Rhythm of lights

Examples

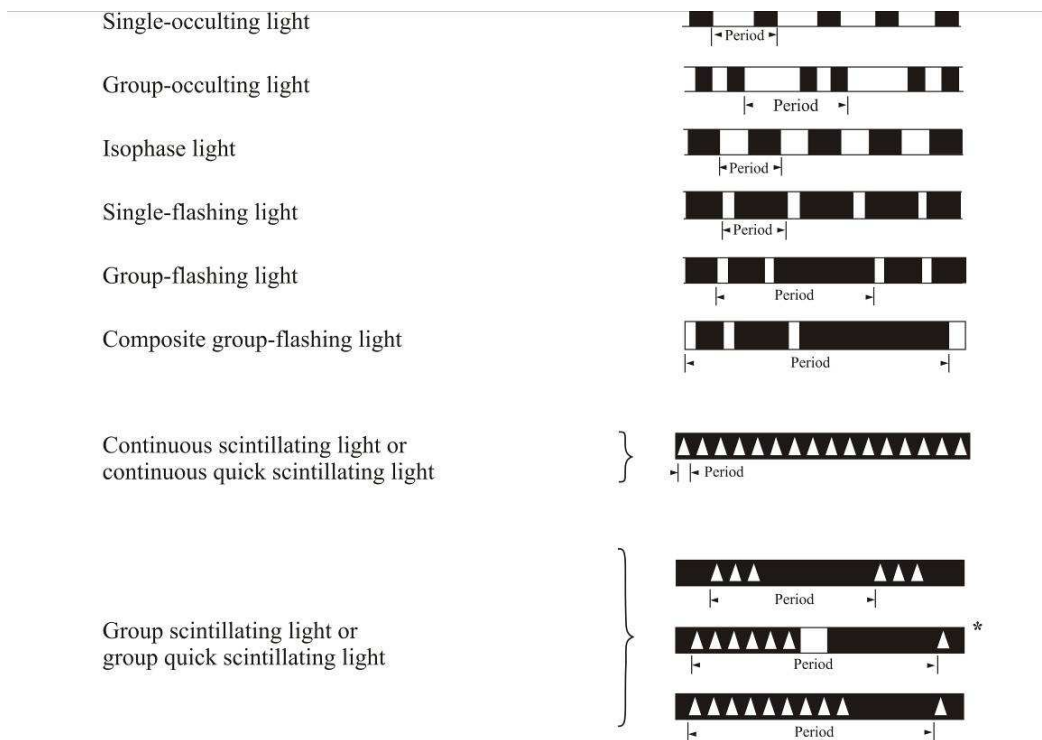

\* In this instance, a long flash permits clear differentiation of the rhythm.

**II. BUOYAGE OF CHANNEL LIMITS IN THE WATERWAY**

1. Right-hand side of the channel

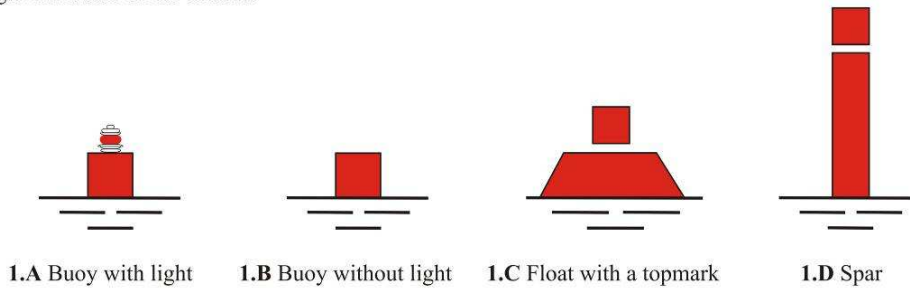

(fig. 1)

Colour: red

Form: cylindrical buoy or buoy with a topmark, or spar

Topmark (if any): red cylinder

Light (when fitted): rhythmic red light

Generally with radar reflector.

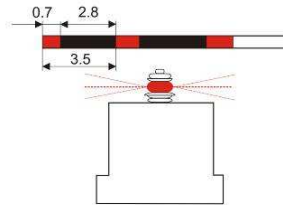

2. Left-hand side of the channel

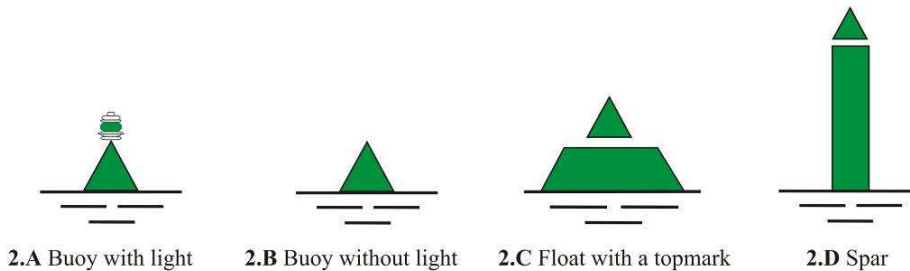

(fig. 2)

Colour: green

Form: conical buoy or buoy with a topmark, or spar

Topmark (if any): green cone, point upwards

Light (when fitted): rhythmic green light

Generally with radar reflector.

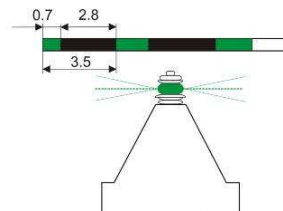

3. Bifurcation of the channel

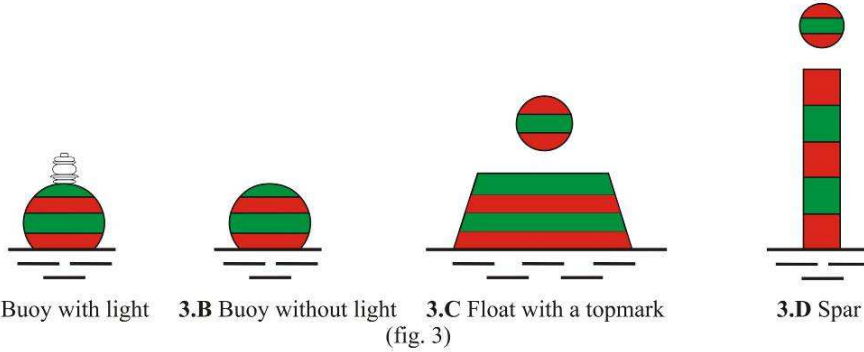

Colour: horizontal red and green bands

Form: spherical buoy or buoy with a topmark, or spar

Topmark (if any): sphere with horizontal red and green bands

Light (when fitted): continuous scintillating white light, or isophase white light (may be the group-flashing white light with a group of three flashes)

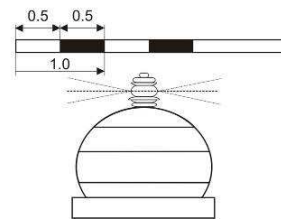

Generally with radar reflector.

Where necessary, a red cylindrical topmark or green conical topmark placed above the bifurcation mark indicates on which side it is preferable to pass (main channel).

The mark shall then bear a rhythmic red light or a rhythmic green light, as appropriate.

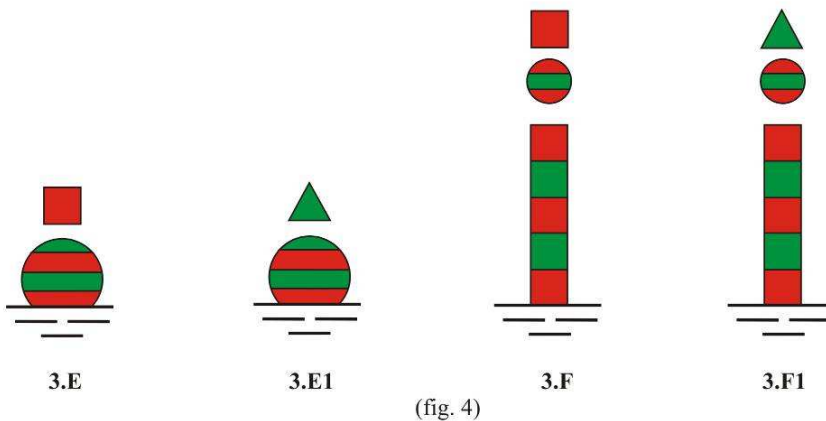

4. A letter "P" painted in white on the buoys described in paragraphs 1 and 2 indicates that the channel is adjacent to a berthing area. If the buoys showing the letter "P" carry a light, its rhythm shall be different from that of the lights of other buoys placed along the channel limit.

### III. MARKS ON LAND INDICATING THE POSITION OF THE CHANNEL

#### A. *Marks on land indicating the position of the channel in relation to the banks*

These marks indicate the position of the channel in relation to the bank and, together with the buoyage of the waterway, mark the channel at points where it approaches a bank; they also serve as landmarks.

#### 1. Channel near the right bank

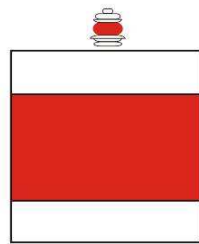

4.A With light

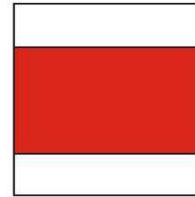

4.B Without light

(fig. 5)

Colour: red/white

Form: post with topmark

Topmark: square boards (sides horizontal and vertical), red, with two horizontal white stripes;

Light (when fitted): rhythmic red light.

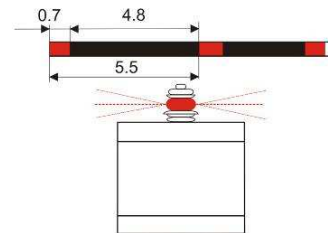

2. Channel near the left bank

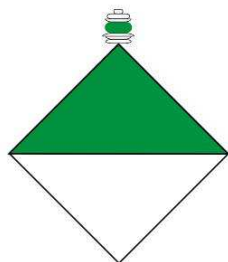

5.A With light

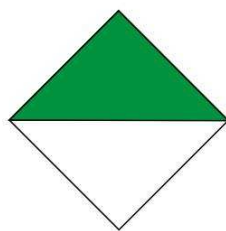

5.B Without light

(fig. 6)

Colour: green/white

Form: post with topmark

Topmarks: square board (diagonals horizontal and vertical),  
upper half painted green and lower half white

Light (when fitted): rhythmic green light.

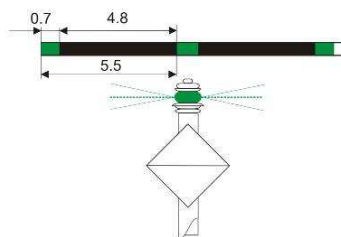

3. Use of marks

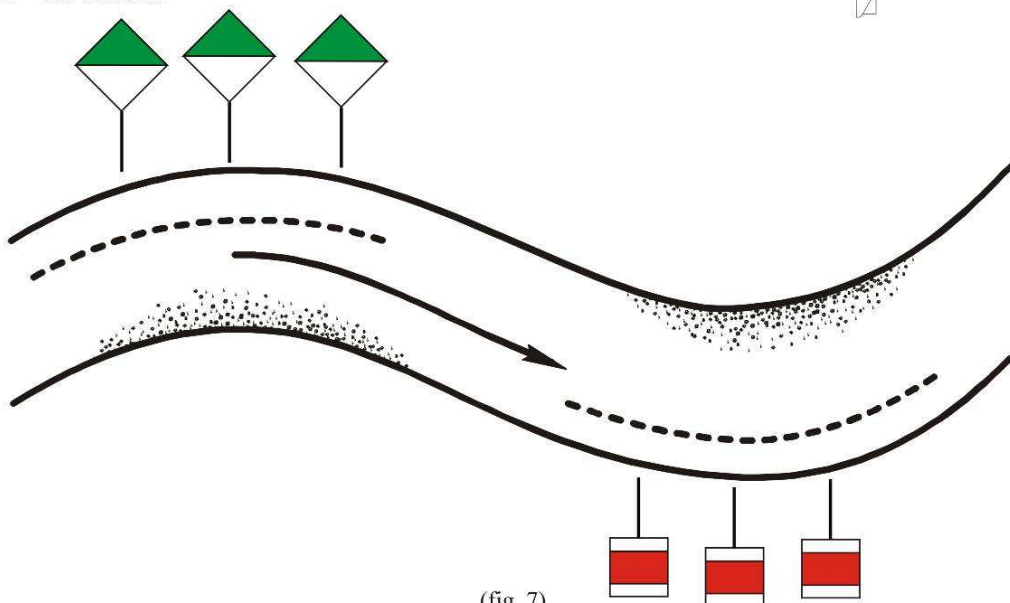

(fig. 7)

B. *Marking of cross-overs*

These marks indicate at what point the channel passes from one bank to another and also give the axis of this cross-over.

1. Right bank

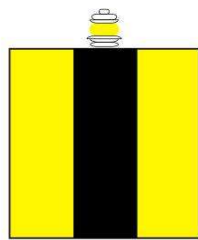

4.C With light

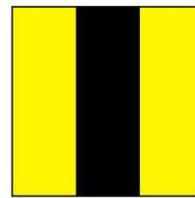

4.D Without light

(fig. 8)

Colour: yellow/black

Form: post with topmark

Topmark: square yellow board (sides horizontal and vertical), with a central vertical black stripe

Light (when fitted): yellow light, flashing or occulting, with an even-number characteristic other than the group-flashing rhythm with a group of two flashes.

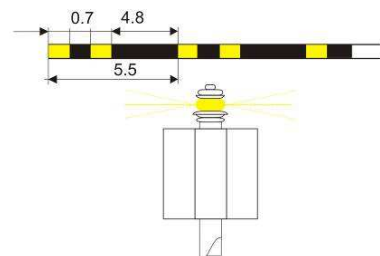

2. Left bank



5.C With light

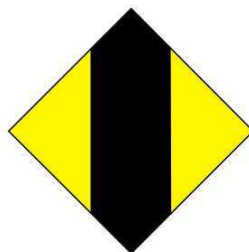

5.D Without light

(fig. 9)

Colour: yellow/black

Form: post with topmark

Topmark: square yellow board (diagonals horizontal and vertical), with a central vertical black stripe

Light (when fitted): yellow light, flashing or occulting, with an odd-number characteristic other than the group-flashing rhythm with a group of three flashes.

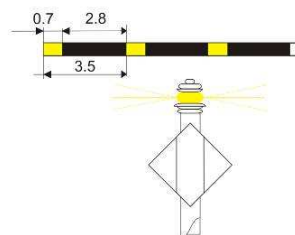

3. Use of marks

3.1 Mere indication of cross-over

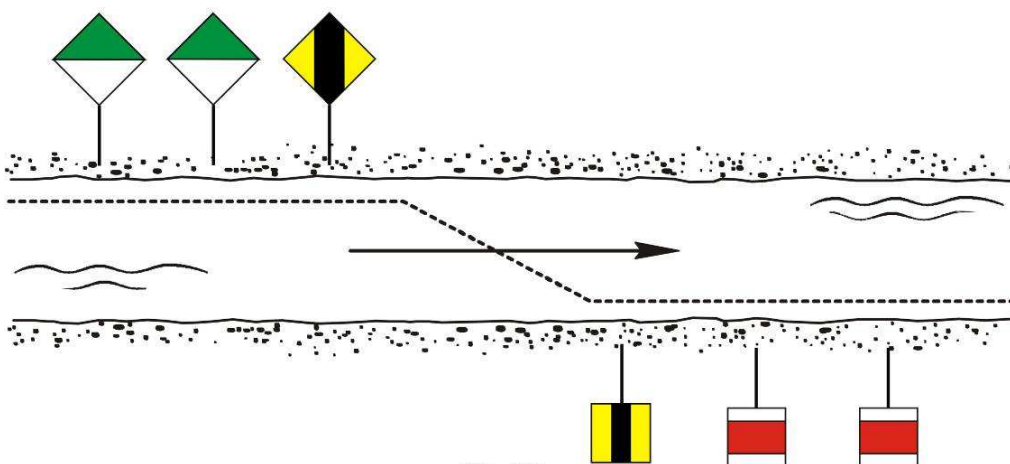

(fig. 10)



3.2 Indication of the axis of a long cross-over

Two identical signs placed one behind the other on the same bank, the first sign positioned lower than the second one, forming an alignment marking the axis of a long cross-over.

Lights (if any): yellow (the forward light and rearward light generally having the same rhythm; however, the rearward light may be a fixed light).

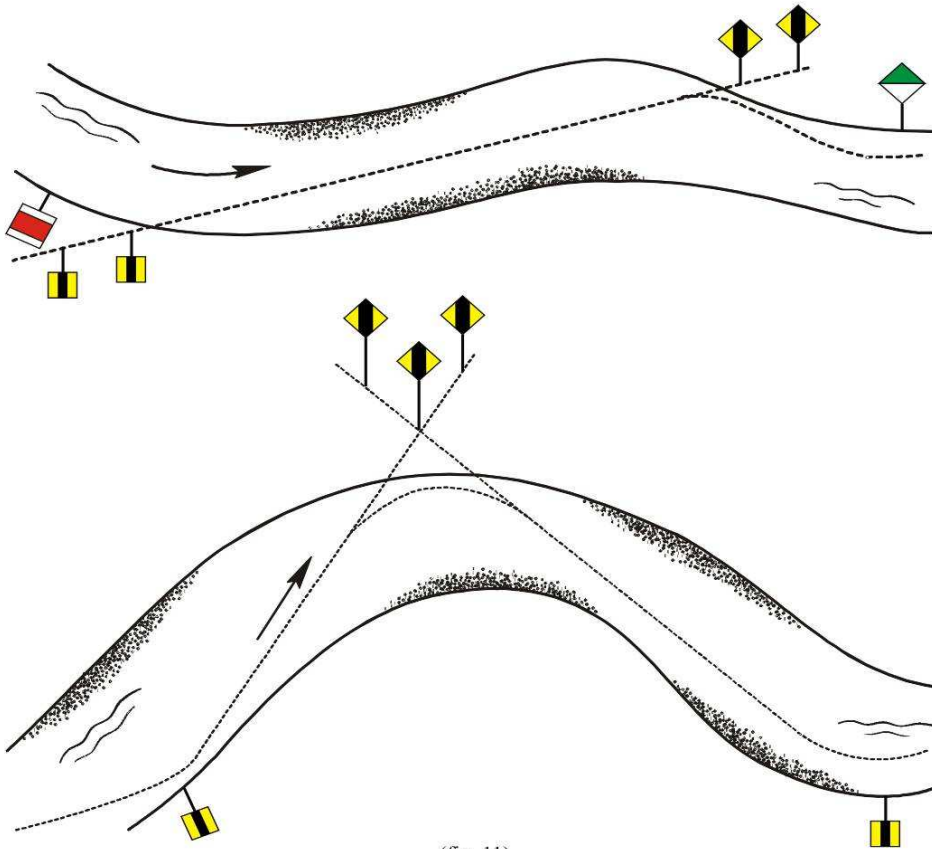

(fig. 11)

**IV. BUOYAGE AND MARKING OF DANGER POINTS AND OBSTACLES**

A. *Fixed marks*

1. Right-hand side

Colour: red  
 Form: post with topmark  
 Topmark: red cone, point downwards  
 Light (when fitted): rhythmic red light.

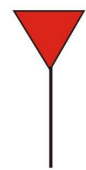

**4.F**  
(fig. 12)

2. Left-hand side

Colour: green  
 Form: post with topmark  
 Topmark: green cone, point upwards  
 Light (when fitted): rhythmic green light.



**5.F**  
(fig. 13)

3. Bifurcation

Colour: red/green  
 Form: post with topmark  
 Topmark: red cone, point downwards, above a green cone, point upwards

Light (when fitted): continuous scintillating white light or isophase white light (may be the group-flashing white light with a group of three flashes)

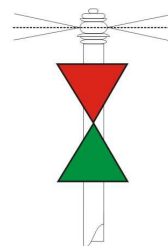

**6.A**



**6.B**

(fig. 14)

The above cones may be replaced by triangular panels with a white background and a red or green border.

4. Secondary arms of the waterway, mouths of waterways and entrances to harbours

On the approach to secondary arms of the waterway, to mouths of waterways and to harbour entrances, the bank walls on both sides of the waterway may be marked as far as the head of the dividing mole by the fixed marks described in 1 and 2 above, figures 12 and 13. Vessels entering the harbour are regarded as upstream traffic.

B. *Buoys*

1. Right-hand side



(fig. 15)

Colour: horizontal red and white bands

Form: spar-buoy or spar

Topmark: red cylinder

Light (when fitted): rhythmic red light  
Generally with radar reflector.

2. Left-hand side

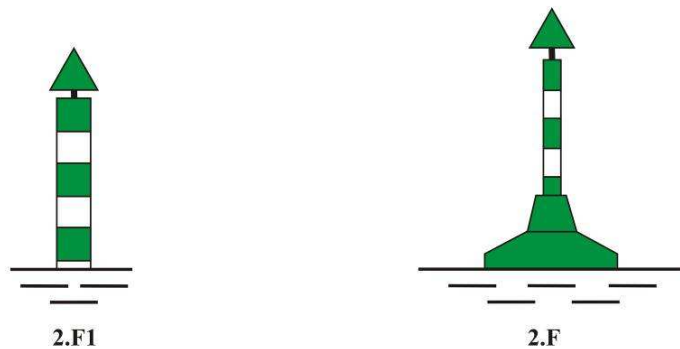

(fig. 16)

Colour: horizontal green and white bands

Form: spar-buoy or spar

Topmark: green cone, point upwards

Light (when fitted): rhythmic green light  
Generally with radar reflector.

*Example of use of the buoyage and marking described in chapters II and IV*

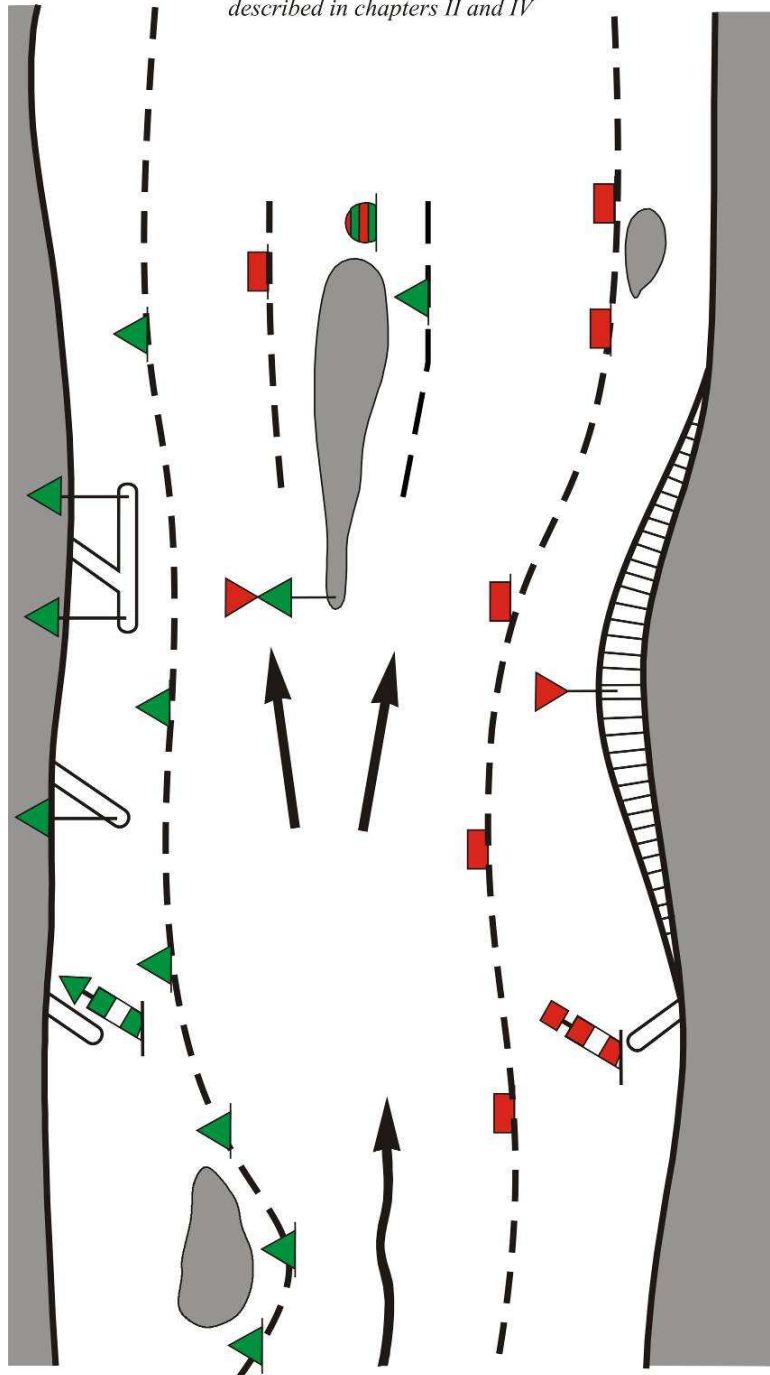

(fig. 17)

**V. ADDITIONAL MARKING FOR NAVIGATION BY RADAR**

**A. Marking of bridge piers (if necessary)**

1. Yellow floats with radar reflector (placed upstream and downstream from piers)

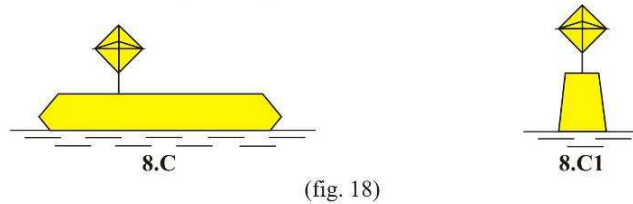

(fig. 18)

2. Pole with radar reflector placed upstream and downstream from bridge piers

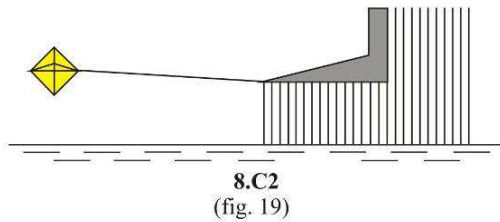

(fig. 19)

**B. Marking of overhead cables (if necessary)**

1. Radar reflectors secured to the overhead cable (giving a radar image of a series of points to identify the overhead cable)

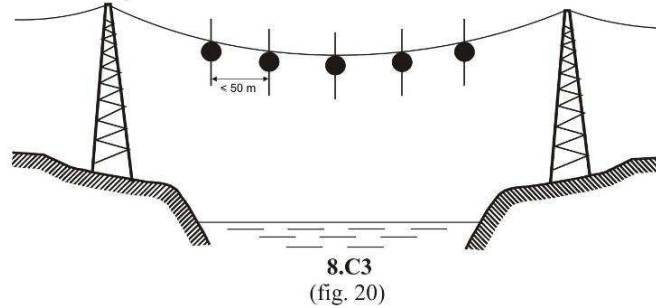

(fig. 20)

2. Radar reflectors placed on yellow floats arranged in pairs near each bank (each pair giving a radar image of two points side by side to identify the overhead cable)

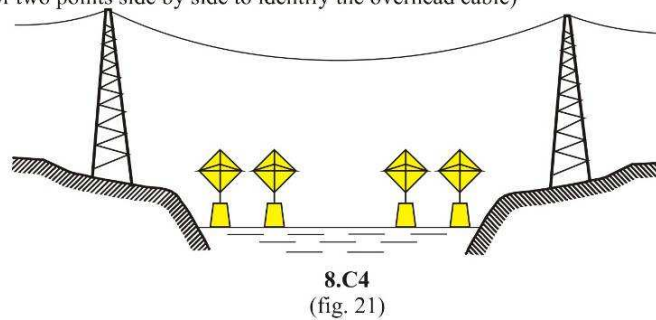

(fig. 21)

## **VI. ADDITIONAL BUOYAGE AND MARKING OF LAKES AND BROAD WATERWAYS**

### *A. Marking of danger points, obstacles and special features*

#### 1. Cardinal marks

##### *Definition of cardinal quadrants and marks*

The four quadrants (North, East, South and West) are bounded by the true bearings NW NE, NE-SE, SE-SW, SW-NW taken from the point of interest.

A cardinal mark is named after the quadrant in which it is placed.

The name of a cardinal mark indicates that the mark should be passed on the side of the quadrant named.

*Description of cardinal marks*

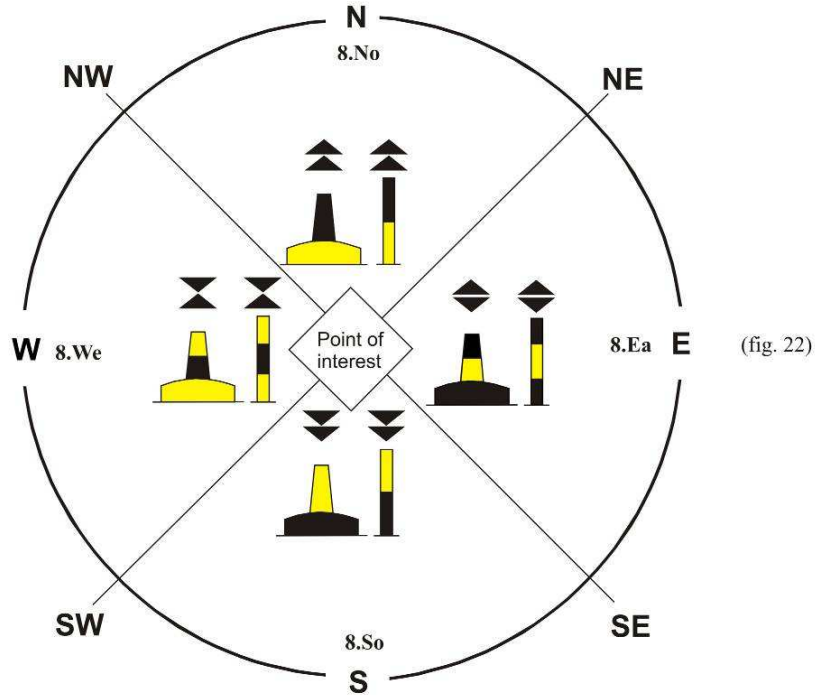

*North cardinal mark*

Colour : black above yellow  
 Form : pillar or spar, with topmark  
 Topmark : two black cones, one above the other, points upward  
 Light (when fitted) :  
 Colour : white  
 Rhythm : continuous quick scintillating or continuous scintillating

*East cardinal mark*

Colour : black with a single broad horizontal yellow band  
 Form : pillar or spar, with topmark  
 Topmark : two black cones, one above the other, base to base  
 Light (when fitted):  
 Colour : white  
 Rhythm : group quick scintillating or group scintillating, with a group of three flashes

*South cardinal mark*

Colour : yellow above black  
 Form : pillar or spar, with topmark  
 Topmark : two black cones, one above the other, points downward  
 Light (when fitted) :  
 Colour : white  
 Rhythm : group quick scintillating or group scintillating, with a group of six flashes followed by a long flash of not less than two seconds duration

*West cardinal mark*

Colour : yellow with a single broad horizontal black band  
 Form : pillar or spar, with topmark  
 Topmark : two black cones, one above the other, point to point  
 Light (when fitted) :  
 Colour : white  
 Rhythm : group quick scintillating or group scintillating, with a group of nine flashes

2. Isolated danger marks

An isolated danger mark is a mark erected on, or moored above an isolated danger which has safe water all around it.

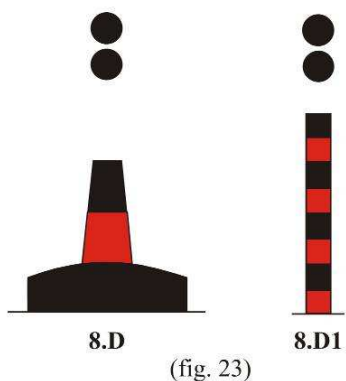

Colour : black with one or more broad horizontal  
 Form : any (generally pillar or spar) with topmark  
 Topmark : two black spheres, one above the other  
 Light (when fitted):  
 Colour : white  
 Rhythm : group flashing (group of two flashes)

B. Marking of the axis of a channel, the middle of a channel or a landfall

Safe-water marks

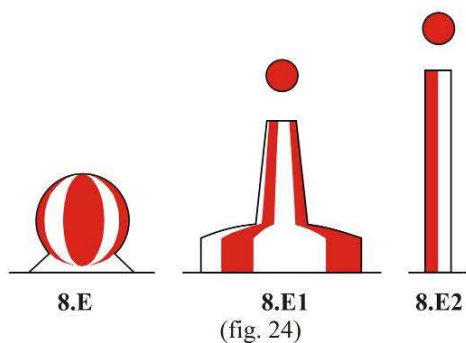

Colour : red and white vertical stripes  
 Form : spherical buoy or pillar or spar with topmark  
 Topmark (if any) : single red sphere  
 Light (when fitted):  
 Colour : white  
 Rhythm : isophase, single-occluding, one long flash every 10 seconds or Morse code "A"



C. *Weather signs and signals on lakes*

*"Caution" warning*

A yellow light producing about 40 flashes per minute constitutes a "caution" warning.

The "caution" warning indicates the probable onset of a dangerous phenomenon without specifying the time thereof.

*"Danger" warning*

A yellow light producing about 90 flashes per minute constitutes a "danger" warning.

The danger warning indicates the imminent arrival of a dangerous phenomenon.

## **VII. MARKING OF PROHIBITED OR RESTRICTED AREAS**

1. Special marks

Colour:	yellow
Form:	any, but different from navigational marks
Topmark (if any):	single yellow "X" shape
Light (when fitted):	
Colour:	yellow
Rhythm:	any, other than those described in chapter VI.

2. The nature of the prohibition or restriction shall, insofar as possible, be made clear in writing (for instance, in charts) and by local information.

Local information may be carried on yellow buoys. It may also be given by means of topmarks placed on such buoys in lieu of a topmark as prescribed above. For example, buoys at the edge of a zone where navigation is totally prohibited may carry a staff with a rigid, triangular red pennon.

Information may be given on boards placed on the bank and representing any of the prohibitory or informative signs prescribed in annex 7, sections I.A and I.E. Such boards may, if necessary, be supplemented by an arrow indicating the direction of the area to which the sign applies (see annex 7, section II.3).

3. If a shore zone in which one or more types of vessel or activity are prohibited or restricted is crossed by a channel in which one such type of vessel or activity is not prohibited or restricted (except as regards an entrance to a harbour to which section II applies), the sides of that channel may, again, be marked by yellow buoys. The upper parts of the two buoys at the entrance may, if necessary, be painted red

on the right-hand side and green on the left-hand side for a boatmaster leaving the channel.

On the bank, boards as prescribed in annex 7, E.15 to E.20, may indicate the type of craft or activity permitted (e.g. the "water skiing" permission sign to indicate a water-skiing channel across an area where all navigation, or only water skiing, is prohibited); the markings may be supplemented by the arrow prescribed in annex 7, section II.3.

Where a zone open for more than one activity is crossed by a channel in which only one activity is permitted, the sides of that channel may be marked as in the above case. A board on the bank may indicate the activity permitted.

## **VIII. BUOYS FOR MISCELLANEOUS PURPOSES**

If buoys are required for purposes other than those referred to above, they shall be predominantly white. They may carry pictograms.

## **IX. ENTRANCES TO HARBOURS**

### 1. Marking of the entrance

By day:

To port of a vessel entering: red device, generally cylindrical; or a post with a cylindrical red topmark; or a red rectangle painted in the jetty;

To starboard of a vessel entering: green device, generally conical; or a post with a conical green topmark; or a green triangle, point upward, painted on the jetty.

At night:

The day markings described above may be illuminated.

If lights are used:

To port of a vessel entering: a red light, generally rhythmic;

To starboard of a vessel entering: a green light, generally rhythmic.

In certain cases, only one of these lights may be used.

### 2. This marking may be also used for entrances to tributary waterways, entrances to secondary arms of waterways and entrances to docks.

The following sketch illustrates the provisions of chapters VI, VII and IX.

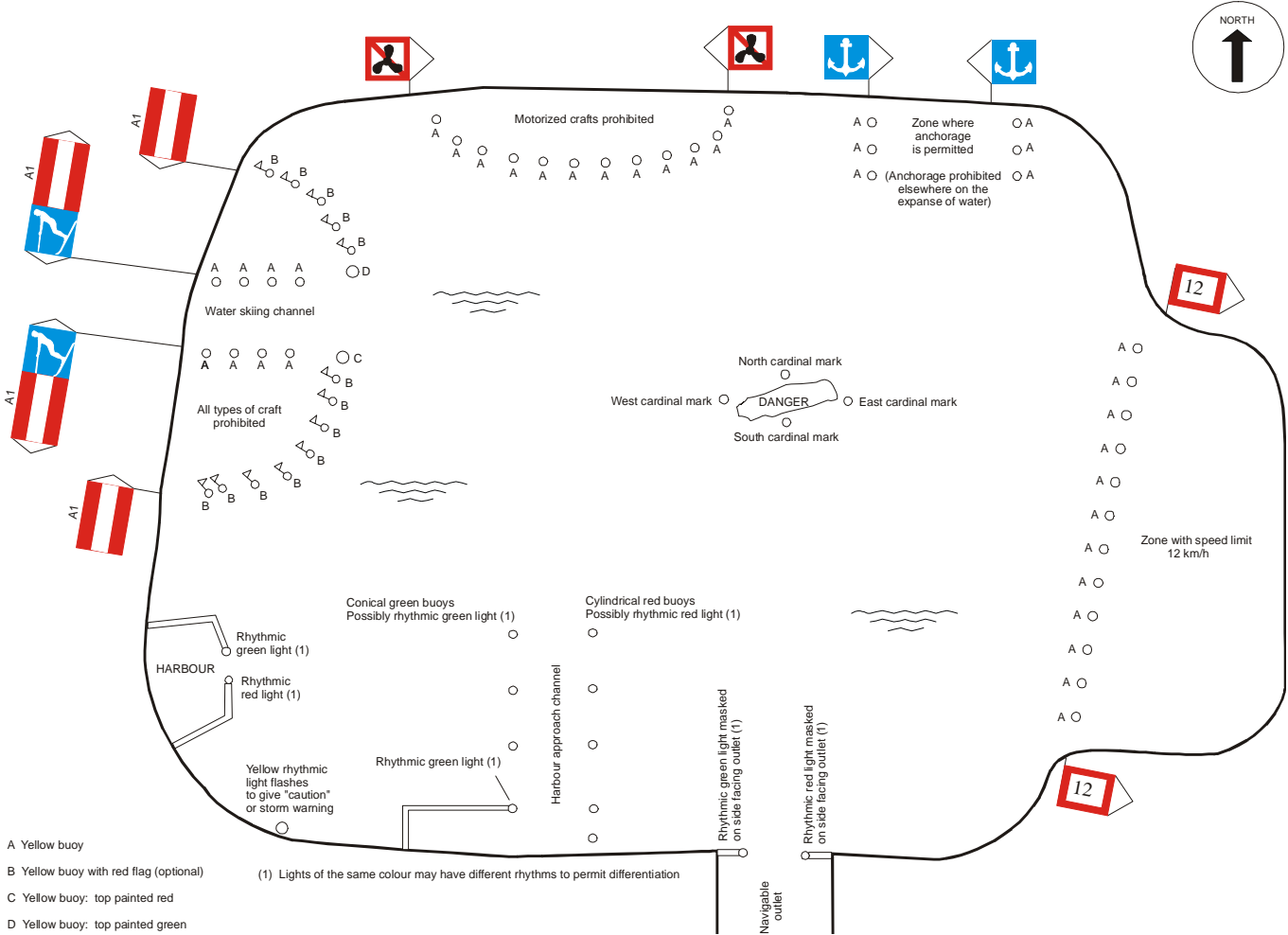

**Annex 9**  
**MODEL USED-OIL LOG**

## **USED-OIL LOG**

Page 1

Order No: \_\_\_\_\_

Type of vessel	Name of vessel
Official number or tonnage measurement number:	
Place of issue:	
Date of issue:	
This log contains _____ pages	
Seal and signature of the authority issuing the log	

Making out of used-oil logs

The first used-oil log, carrying order number 1 on page 1, is issued only by the authority which made out the vessel's certificate. This authority shall also enter the required particulars on page 1.

All the following logs, numbered by order, shall be made out by a competent local authority, but shall only be issued on presentation of the previous log. The previous log shall be indelibly stamped "Not valid" and returned to the boatmaster. It shall be kept on board for six months following the last entry.

Page 2 and following

**Oily and greasy wastes accepted, occurring during the operation of the vessel:**

Waste oil: ..... 1

Bilge water from:

Aft engine room ..... 1

Fore engine room ..... 1

Other premises ..... 1

Other oily and greasy wastes:

Used rags ..... kg

Waste grease ..... kg

Used filters ..... units

Receptacles ..... units

.....  
Other comments:

.....  
Place: ..... Date: .....

Seal and signature of the reception facility

**Annex 10**

**GENERAL TECHNICAL SPECIFICATIONS  
APPLICABLE TO RADAR EQUIPMENT**

**(Left void)<sup>4</sup>**

---

<sup>4</sup> Requirements applicable to radar equipment shall be included in Recommendations on Harmonized Europe-Wide Technical Requirements for Inland Navigation Vessels<sup>4</sup> (Resolution No. 61).