

INLAND TRANSPORT COMMITTEE

Working Party on the Transport of Dangerous Goods

Joint Meeting of the RID Committee of Experts and the  
Working Party on the Transport of Dangerous Goods

Bern 23-27 March 2009

Item 6 of the provisional agenda

**PROPOSALS FOR AMENDMENTS TO RID/ADR/ADN**

Section 5.4.1: Dangerous goods transport document and information  
with reference to environmentally hazardous substances

Addendum to ECE/TRANS/WP.15/AC.1/2009/4

Transmitted by the Government of Sweden

1. This paper deals with the issues in proposal ECE/TRANS/WP.15/AC.1/2009/4.
2. The criteria, marking and documentation provisions for substances which are marine pollutant have changed in the 2008 edition of the IMDG Code. The criteria in the IMDG Code and in ADR/RID are based on those developed by United Nations Globally Harmonized System of Classification and Labelling Chemicals (GHS).
3. In accordance with paragraph 5.3.2.3 in the IMDG Code, a cargo transport unit shall be marked with the symbol fish and tree, when containing any substances which are marine pollutant.
4. Furthermore, a package containing a marine pollutant shall be marked in accordance to paragraph 5.2.1.6 in the IMDG Code. However, the mark in the IMDG Code is called "marine pollutant mark". In ADR/RID, this mark is called "environmentally hazardous mark".
5. The documentation provisions in 5.4.1.4.3 of the IMDG Code require the inscription "Marine pollutant" when such a substances is transported. Since this requirement already occurs in the IMDG Code, Sweden proposes to allow either the inscription "Environmentally hazardous" or "Marine pollutant" in the transport document for carriage in a transport chain including maritime carriage. We believe this will facilitate multimodal transport.
6. Sweden would also like to include a note in 5.2.1.8.3, below the environmentally hazardous mark, informing that this mark is called "marine pollutant mark "in the IMDG code.

**PROPOSAL 1:**

Add a new sub paragraph 5.4.1.1.X with the following wording:

**“5.4.1.1.X Special provisions for carriage of environmentally hazardous substances**

When a substance belonging to one of classes 1 to 9 meets the classification criteria of 2.2.9.1.10, the transport document shall bear the inscription “Environmentally hazardous”. This requirement does not apply to UN Nos. 3077 and 3082. Inscription according to chapter 5.4.1.4.3 of the IMDG Code is also acceptable for carriage in a transport chain including maritime carriage.”

**PROPOSAL 2:**

Add a new note in 5.2.1.8.3 (new text is underlined)

“5.2.1.8.3 The environmentally hazardous substance mark shall be as shown below. The dimensions shall be 100 mm × 100 mm, except in the case of packages of such dimensions that they can only bear smaller marks.



Symbol (fish and tree): black on white or suitable contrasting background

“**Note:** This mark is called *Marine pollutant mark in the IMDG Code.*””

## Chapter 2.10

### *Marine pollutants*

**2**

#### 2.10.1 Definition

*Marine pollutants* means substances which are subject to the provisions of Annex III of MARPOL 73/78, as amended.

#### 2.10.2 General provisions

2.10.2.1 Marine pollutants shall be transported under the provisions of Annex III of MARPOL 73/78, as amended.

2.10.2.2 The Index indicates by the symbol **P** in the column headed **MP** those substances, materials and articles that are identified as marine pollutants.

2.10.2.3 Marine pollutants shall be transported under the appropriate entry according to their properties if they fall within the criteria of any of the classes 1 to 8. If they do not fall within the criteria of any of these classes, they shall be transported under the entry: ENVIRONMENTALLY HAZARDOUS SUBSTANCE, SOLID, N.O.S., UN 3077 or ENVIRONMENTALLY HAZARDOUS SUBSTANCE, LIQUID, N.O.S., UN 3082, as appropriate, unless there is a specific entry in class 9.

2.10.2.4 Column 4 of the Dangerous Goods List also provides information on marine pollutants using the symbol **P**.

2.10.2.5 When a substance, material or article possesses properties that meet the criteria of a marine pollutant but is not identified in this Code, such substance, material or article shall be transported as a marine pollutant in accordance with the Code.

2.10.2.6 With the approval of the competent authority (see 7.9.2), substances, materials or articles that are identified as marine pollutants in this Code but which no longer meet the criteria as a marine pollutant need not be transported in accordance with the provisions of this Code applicable to marine pollutants.

#### 2.10.3 Classification

2.10.3.1 Marine pollutants shall be classified in accordance with chapter 2.9.3.

**Part 5 – Consignment procedures**

- 5.2.1.5.5 Each package which conforms to a design approved by the competent authority under 6.4.22.1–6.4.22.5 or 6.4.24.2–6.4.24.3 shall be legibly and durably marked on the outside of the packaging with:
- .1 the identification mark allocated to that design by the competent authority;
  - .2 a serial number to uniquely identify each packaging which conforms to that design;
  - .3 in the case of a Type B(U) or Type B(M) package design, with “TYPE B(U)” or “TYPE B(M)”;
  - .4 in the case of a Type C package design, with “TYPE C”.
- 5.2.1.5.6 Each package which conforms to a Type B(U), Type B(M) or Type C package design shall have the outside of the outermost receptacle which is resistant to the effects of fire and water plainly marked by embossing, stamping or other means resistant to the effects of fire and water with the trefoil symbol shown below.

Basic trefoil symbol with proportions based on a central circle of radius  $X$ .  
The minimum allowable size of  $X$  shall be 4 mm.

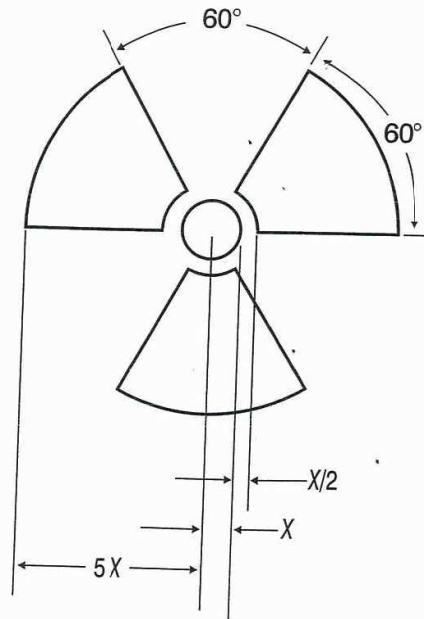

5

- 5.2.1.5.7 Where LSA-I or SCO-I material is contained in receptacles or wrapping materials and is transported under exclusive use as permitted by 4.1.9.2.3, the outer surface of these receptacles or wrapping materials may bear the marking “RADIOACTIVE LSA-I” or “RADIOACTIVE SCO-I”, as appropriate.
- 5.2.1.5.8 In case of international transport of packages requiring competent authority design or shipment approval, for which different approval types apply in the different countries concerned, marking shall be in accordance with the certificate of the country of origin of the design.
- 5.2.1.6 **Special marking provisions for marine pollutants**
- 5.2.1.6.1 Packages containing marine pollutants meeting the criteria of 2.10.3 shall be durably marked with the marine pollutant mark with the exception of single packagings and combination packagings containing inner packagings with:
- contents of 5 ℓ or less for liquids; or
  - contents of 5 kg or less for solids.
- 5.2.1.6.2 The marine pollutant mark shall be located adjacent to the markings required by 5.2.1.1. The provisions of 5.2.1.2 and 5.2.1.4 shall be met.

Chapter 5.2 – Marking and labelling of packages including IBCs

- 5.2.1.6.3 The marine pollutant mark shall be as shown below. For packagings, the dimensions shall be at least 100 mm × 100 mm, except in the case of packages of such dimensions that they can only bear smaller marks.

Marine pollutant mark



Symbol (fish and tree): black on white or suitable contrasting background

- 5.2.1.7 Except as provided in 5.2.1.7.1:
- combination packagings having inner packagings containing liquid dangerous goods;
  - single packagings fitted with vents; and
  - cryogenic receptacles intended for the transport of refrigerated liquefied gases

shall be legibly marked with package orientation arrows which are similar to the illustration shown below or with those meeting the specifications of ISO 780:1985. The orientation arrows shall appear on two opposite vertical sides of the package with the arrows pointing in the correct upright direction. They shall be rectangular and of a size that is clearly visible commensurate with the size of the package. Depicting a rectangular border around the arrows is optional.

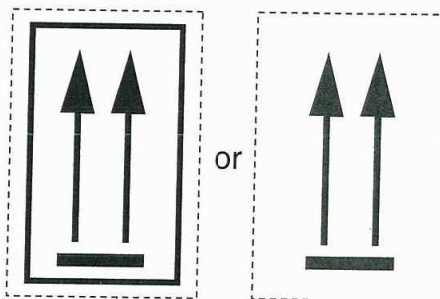

Two black or red arrows on white or suitable contrasting background.  
The rectangular border is optional

- 5.2.1.7.1 Orientation arrows are not required on packages containing:
- (a) pressure receptacles except for cryogenic receptacles;
  - (b) dangerous goods in inner packagings of not more than 120 ml which are prepared with sufficient absorbent material between the inner and outer packagings to completely absorb the liquid contents;
  - (c) class 6.2 infectious substances in primary receptacles of not more than 50 ml;
  - (d) class 7 radioactive material in Type IP-2, IP-3, A, B(U), B(M) or C packages; or
  - (e) articles which are leak-tight in all orientations (e.g. alcohol or mercury in thermometers, aerosols, etc.).
- 5.2.1.7.2 Arrows for purposes other than indicating proper package orientation shall not be displayed on a package marked in accordance with this sub-section.
- 5.2.1.8 **Excepted quantity mark**
- 5.2.1.8.1 Packages containing excepted quantities of dangerous goods shall be marked according to 3.5.4.

Chapter 5.3 – Placarding and marking of cargo transport units

5.3.2.3 Marine pollutant mark

Cargo transport units containing marine pollutants shall clearly display the marine pollutant mark in locations indicated in 5.3.1.1.4.1, even if the cargo transport unit contains packages not required to bear the marine pollutant mark. The mark shall conform to the specifications given in 5.2.1.6.3, and shall have minimum dimensions of 250 mm × 250 mm.

5.3.2.4 Limited quantities

Cargo transport units containing dangerous goods in only limited quantities need not be placarded nor marked according to 5.3.2.0 and 5.3.2.1. They shall, however, be suitably marked on the exterior as "LIMITED QUANTITIES" or "LTD QTY" not less than 65 mm high in locations indicated in 5.3.1.1.4.1.

5.3.2.5 Fumigated units

- .1 The marking of the Proper Shipping Name (FUMIGATED UNIT) and the UN Number (UN 3359) is not required on fumigated units. However, if a fumigated unit is loaded with dangerous goods, any mark required by the provisions in 5.3.2.0 to 5.3.2.4 shall be marked on the fumigated unit.
- .2 A fumigated unit shall be marked with the warning sign, as specified in .3, affixed in a location where it will be easily seen by persons attempting to enter the interior of the unit. The marking, as required by this paragraph, shall remain on the unit until the following provisions are met:
  - .1 the fumigated unit has been ventilated to remove harmful concentrations of fumigant gas; and
  - .2 the fumigated goods or materials have been unloaded.
- .3 The fumigation warning sign shall be rectangular and shall be not less than 300 mm wide and 250 mm high. The markings shall be in black print on a white background with lettering not less than 25 mm high. An illustration of this sign is given below:

Fumigation warning sign

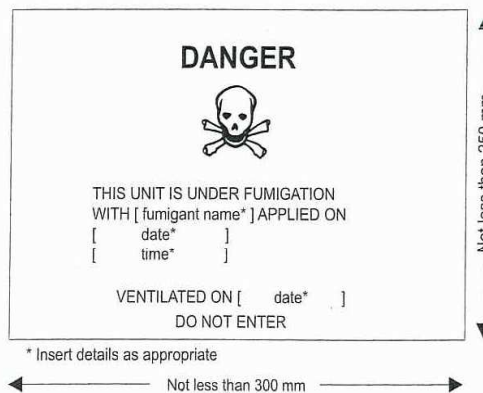

Chapter 5.4 – Documentation

5.4.1.4 Information required on the dangerous goods transport document

5.4.1.4.1 *Dangerous goods description*

The dangerous goods transport document shall contain the following information for each dangerous substance, material or article offered for transport:

- .1 The UN Number preceded by the letters "UN";
- .2 The Proper Shipping Name, as determined according to 3.1.2, including the technical name enclosed in parenthesis, as applicable (see 3.1.2.8);
- .3 The primary hazard class or, when assigned, the division of the goods, including, for class 1, the compatibility group letter. The words "Class" or "Division" may be included preceding the primary hazard class or division numbers;
- .4 Subsidiary hazard class or division number(s) corresponding to the subsidiary risk label(s) required to be applied, when assigned, shall be entered following the primary hazard class or division and shall be enclosed in parenthesis. The words "Class" or "Division" may be included preceding the subsidiary hazard class or division numbers;
- .5 Where assigned, the packing group for the substance or article, which may be preceded by "PG" (e.g. "PG II").

5.4.1.4.2 *Sequence of the dangerous goods description*

The five elements of the dangerous goods description specified in 5.4.1.4.1 shall be shown in the order listed above (i.e. .1, .2, .3, .4, and .5) with no information interspersed, except as provided in this Code. Unless permitted or required by this Code, additional information shall be placed after the dangerous goods description.

5.4.1.4.3 *Information which supplements the Proper Shipping Name in the dangerous goods description*

The Proper Shipping Name (see 3.1.2) in the dangerous goods description shall be supplemented as follows:

- .1 *Technical names for "n.o.s." and other generic descriptions:* Proper Shipping Names that are assigned special provision 274 in column 6 of the Dangerous Goods List shall be supplemented with their technical or chemical group names as described in 3.1.2.8;
- .2 *Empty uncleaned packagings, bulk containers and tanks:* Empty means of containment (including packagings, IBCs, bulk containers, portable tanks, road tank vehicles and railway tank wagons) which contain the residue of dangerous goods of classes other than class 7 shall be described as such by, for example, placing the words "EMPTY UNCLEANED" or "RESIDUE LAST CONTAINED" before or after the Proper Shipping Name;
- .3 *Wastes:* For waste dangerous goods (other than radioactive wastes) which are being transported for disposal, or for processing for disposal, the Proper Shipping Name shall be preceded by the word "WASTE", unless this is already a part of the Proper Shipping Name;
- .4 *Elevated temperature substances:* If the Proper Shipping Name of a substance which is transported or offered for transport in a liquid state at a temperature equal to or exceeding 100°C, or in a solid state at a temperature equal to or exceeding 240°C, does not convey the elevated temperature condition (for example, by using the term "MOLTEN" or "ELEVATED TEMPERATURE" as part of the Proper Shipping Name), the word "HOT" shall immediately precede the Proper Shipping Name.
- .5 *Marine pollutants:* If the goods to be transported are marine pollutants, the goods shall be identified as "MARINE POLLUTANT", and for generic or "not otherwise specified" (N.O.S.) entries the Proper Shipping Name shall be supplemented with the recognized chemical name of the marine pollutant (see 3.1.2.9);
- .6 *Flashpoint:* If the dangerous goods to be transported have a flashpoint of 60°C or below (in °C closed-cup (c.c.)), the minimum flashpoint shall be indicated. Because of the presence of impurities, the flashpoint may be lower or higher than the reference temperature indicated in the Dangerous Goods List for the substance. For class 5.2 organic peroxides which are also flammable, the flashpoint need not be declared.

5.4.1.4.4 *Examples of dangerous goods descriptions:*

UN1098 ALLYL ALCOHOL 6.1 (3) I (21°C c.c.)

UN1098, ALLYL ALCOHOL, class 6.1, (class 3), PG I, (21°C c.c.)

UN 1092, Acrolein, stabilized, class 6.1 (3), PG I, (-24°C c.c.) MARINE POLLUTANT

UN 2761, Organochlorine pesticide, solid, toxic, (Aldrin 19%), class 6.1, PG III, MARINE POLLUTANT